



# PEOPLE 4 PEOPLE In Lego

Model instructions by Bird Brick Builds  
Author: Eduardo Sousa  
155 Parts

# About P4P:

People 4 People is a place to share and discuss solutions and strategies for the daily challenges mainly related to Human Resources (HR).

The community meetups, destined essentially for professionals related to people management, business management, teachers and students, will be held on a bimonthly basis and aims to bring together real people around real issues and interests, promoting debate, the development and definition of solutions and strategies for the Human Resources area.





Mariana Perfeito

UX/UI Designer at Fabamaq and creator of the original P4P logo, is also the designer of my wedding invitations. With a passion for design and a talent for visual communication, Mariana's work on the P4P logo has helped to establish the community's identity and values. (And I really like her work so, hope she likes my adaptation)

Lego designer and Head of Embedded Systems at Fabamaq, accepted the challenge made by Luis Silva to create the Lego representation of the P4P logo. With a passion for lego and a skilled hand, I tried my best, bringing it to life with careful attention to detail and dedication.



Eduardo Sousa



Luis Silva

Head of People, Interaction & Brand at Fabamaq and one of the founders of P4P, is not only a colleague but also a good friend. (hope he like the adaptation). With his extensive experience in people management (and a smile on his face), Luis is a driving force behind the P4P community.



# Attribution-NonCommercial-ShareAlike 4.0 International (CC BY-NC-SA 4.0)

This is a human-readable summary of (and not a substitute for) the [license](#). [Disclaimer](#).

## You are free to:

**Share** — copy and redistribute the material in any medium or format

**Adapt** — remix, transform, and build upon the material

The licensor cannot revoke these freedoms as long as you follow the license terms.

---

## Under the following terms:



**Attribution** — You must give [appropriate credit](#), provide a link to the license, and [indicate if changes were made](#). You may do so in any reasonable manner, but not in any way that suggests the licensor endorses you or your use.



**NonCommercial** — You may not use the material for [commercial purposes](#).



**ShareAlike** — If you remix, transform, or build upon the material, you must distribute your contributions under the [same license](#) as the original.

**No additional restrictions** — You may not apply legal terms or [technological measures](#) that legally restrict others from doing anything the license permits.

---

## Notices:

You do not have to comply with the license for elements of the material in the public domain or where your use is permitted by an applicable [exception or limitation](#).

No warranties are given. The license may not give you all of the permissions necessary for your intended use. For example, other rights such as [publicity, privacy, or moral rights](#) may limit how you use the material.

1

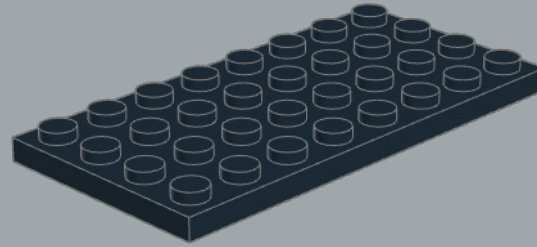
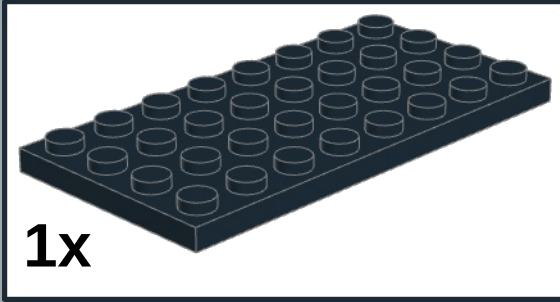

2

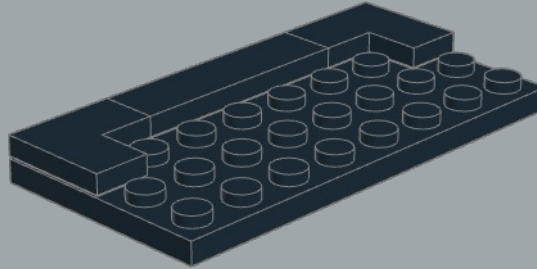
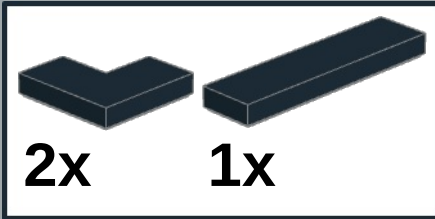

3

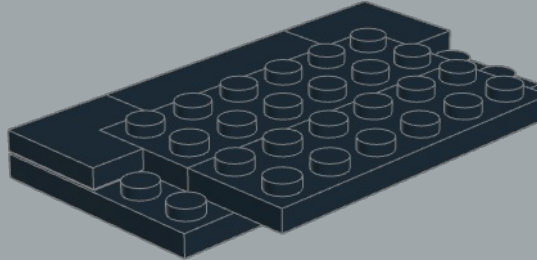
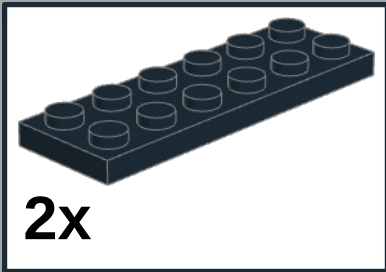

4

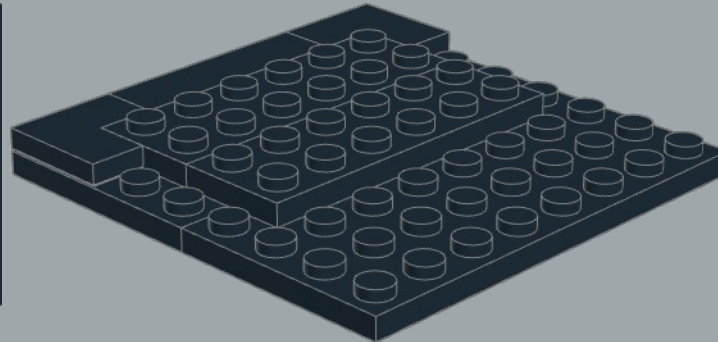
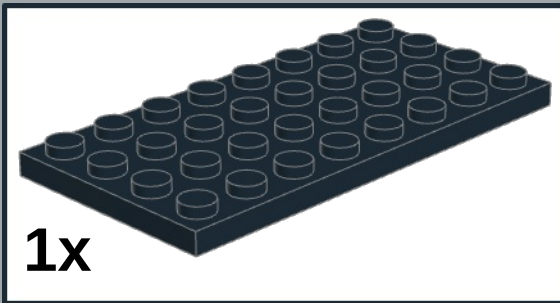

5

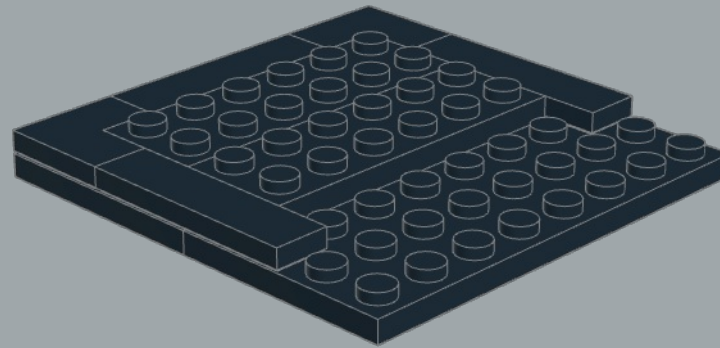
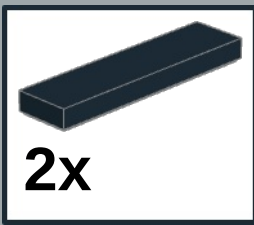

6

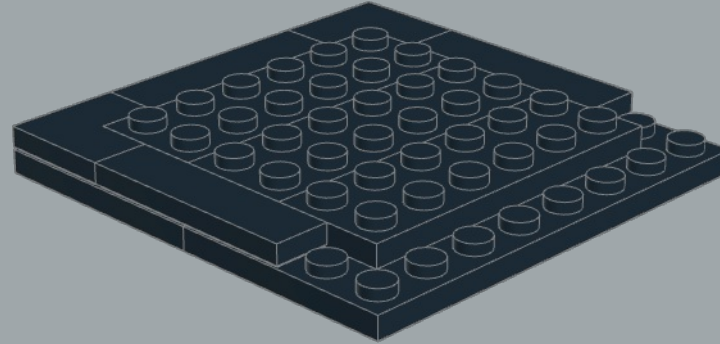
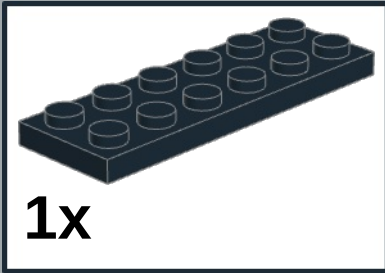

7

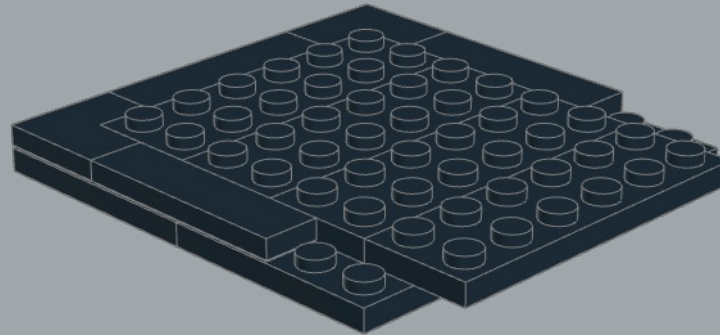
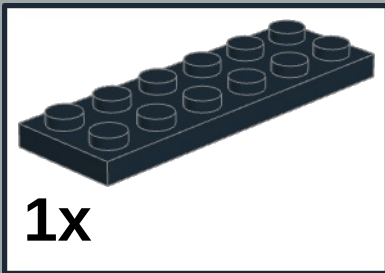

8

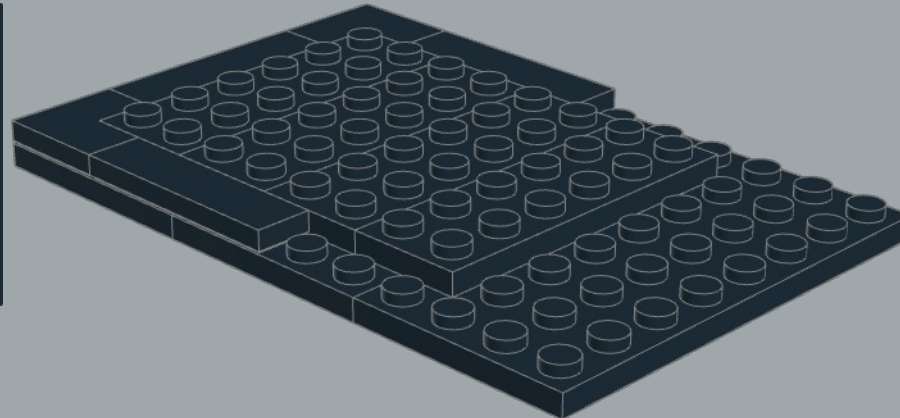
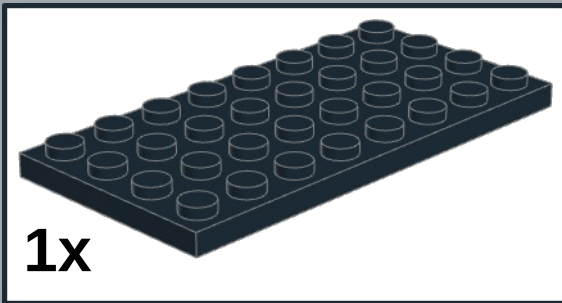

9

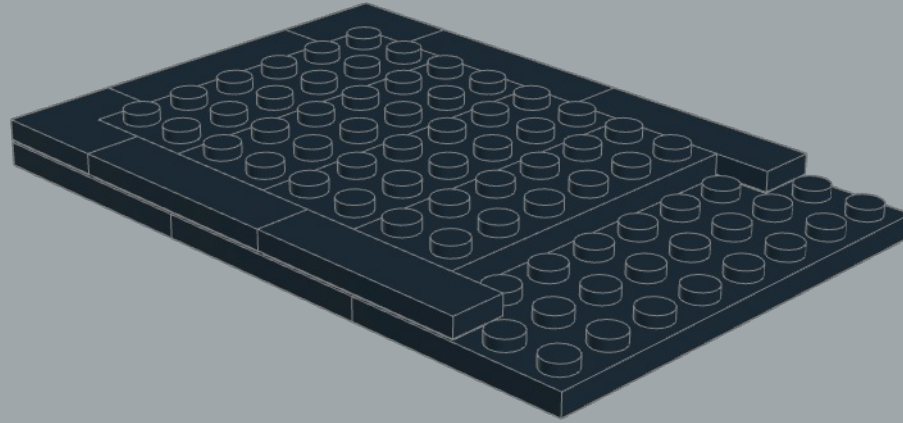
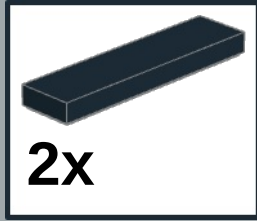

10

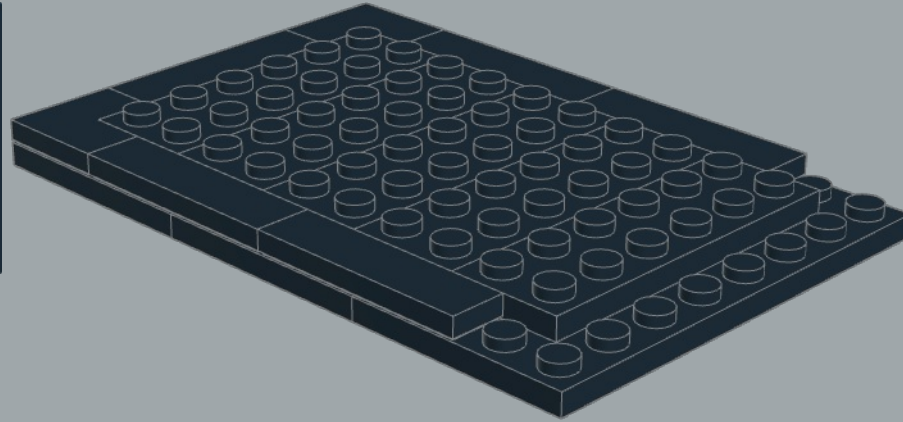
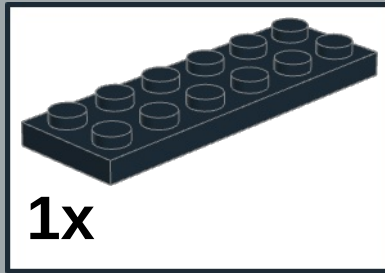

11

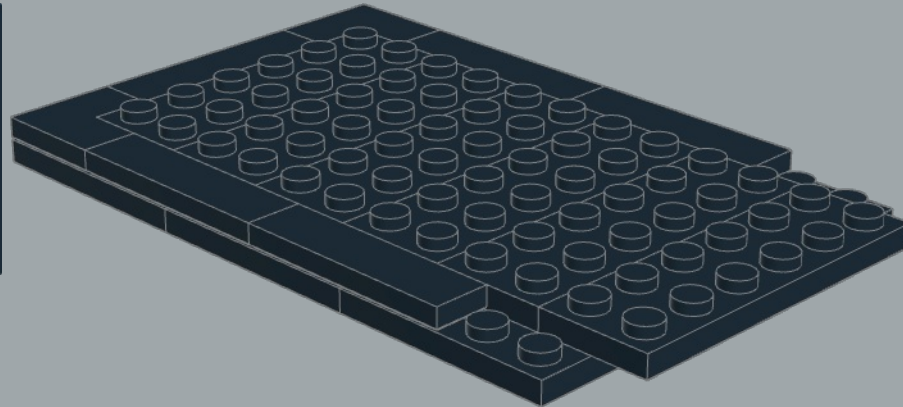
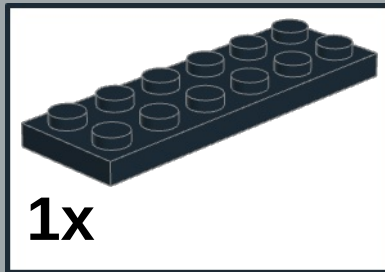

12

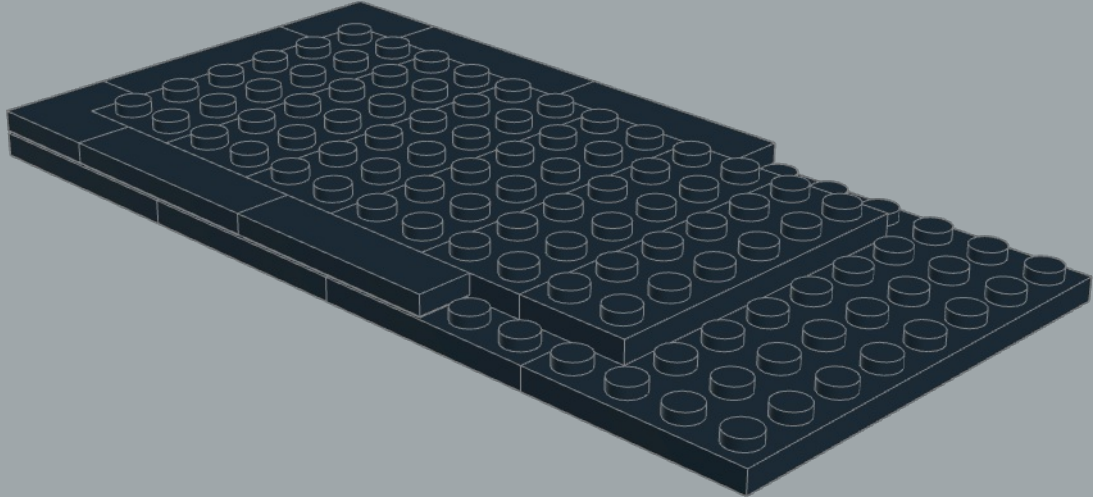
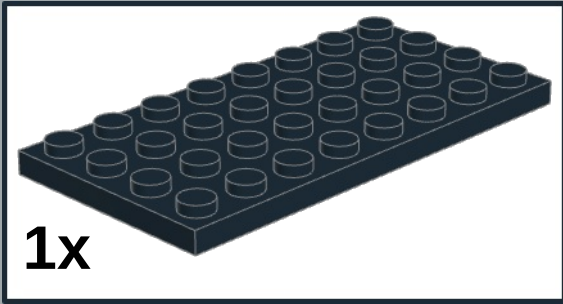

13

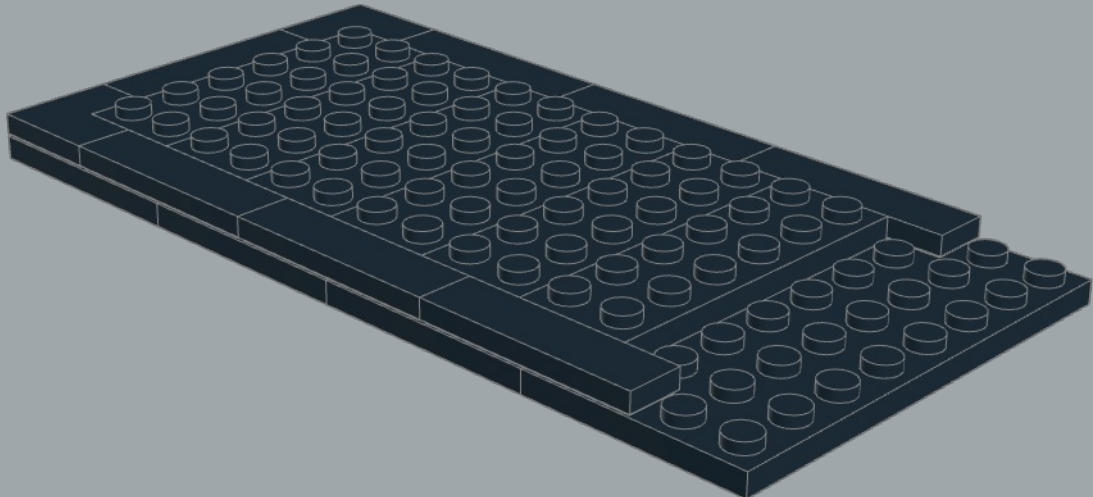
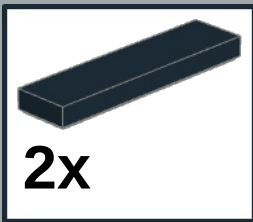

14

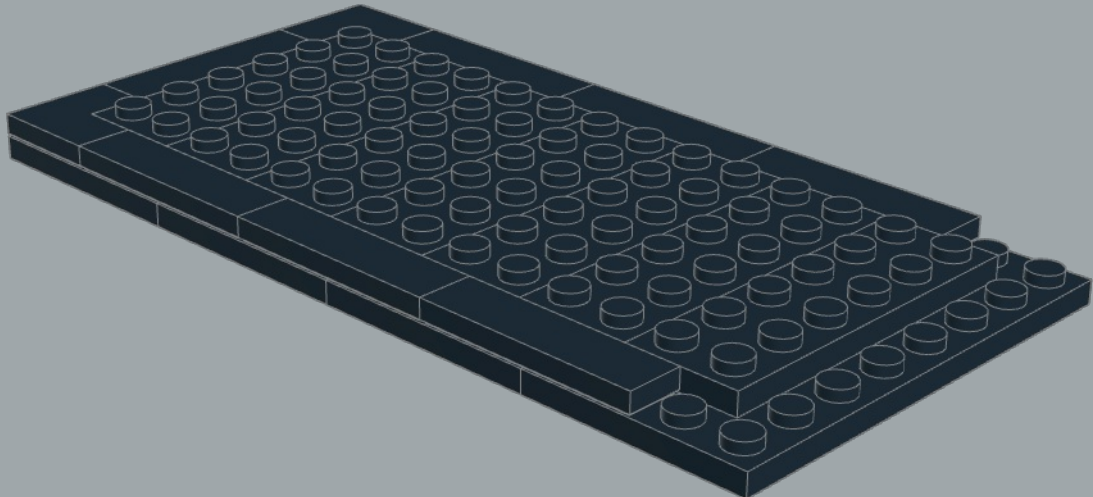
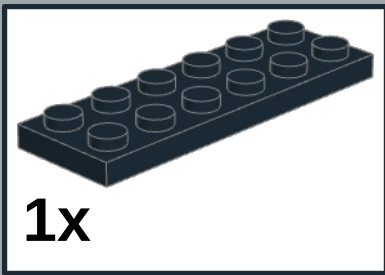



15

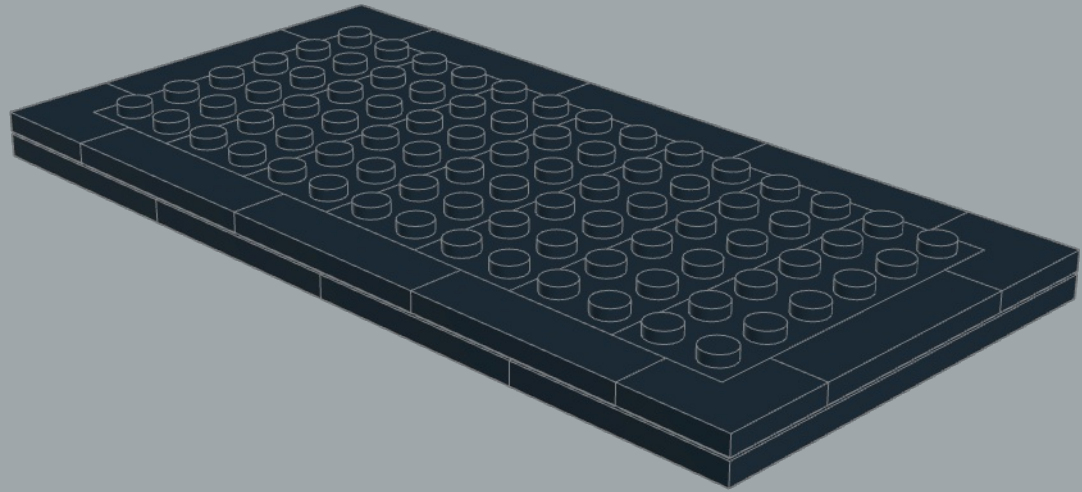
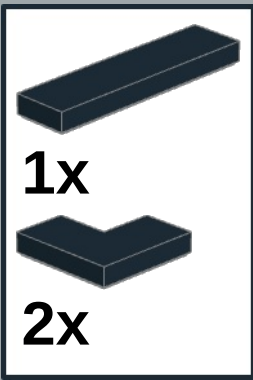

16

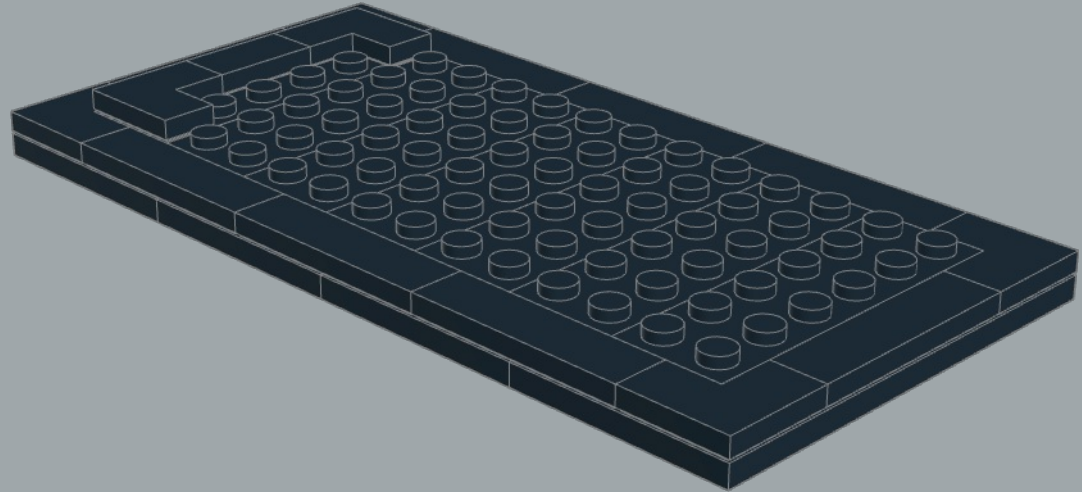
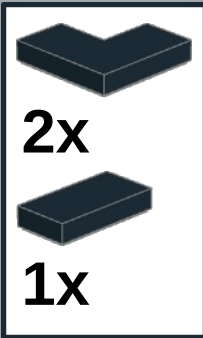

17

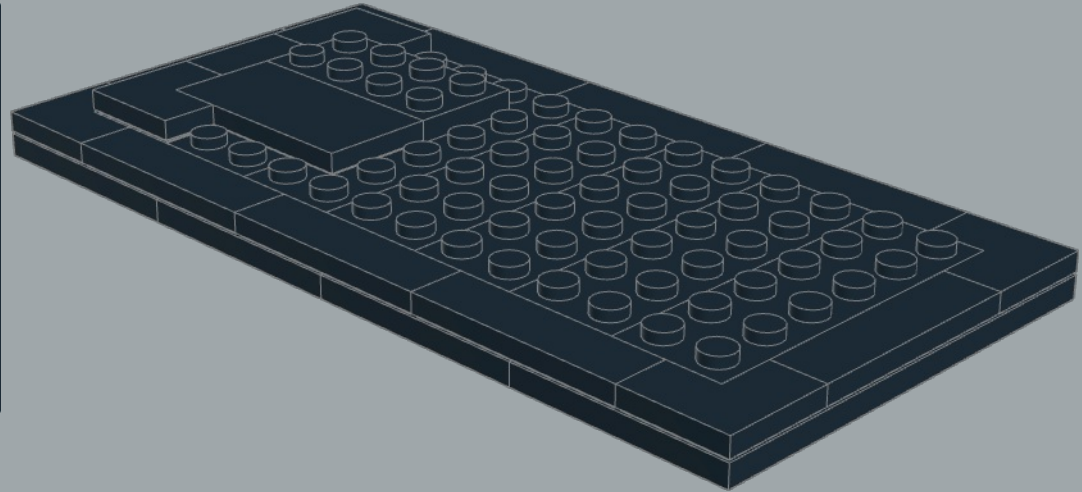
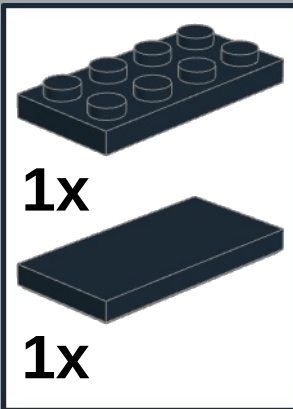

18

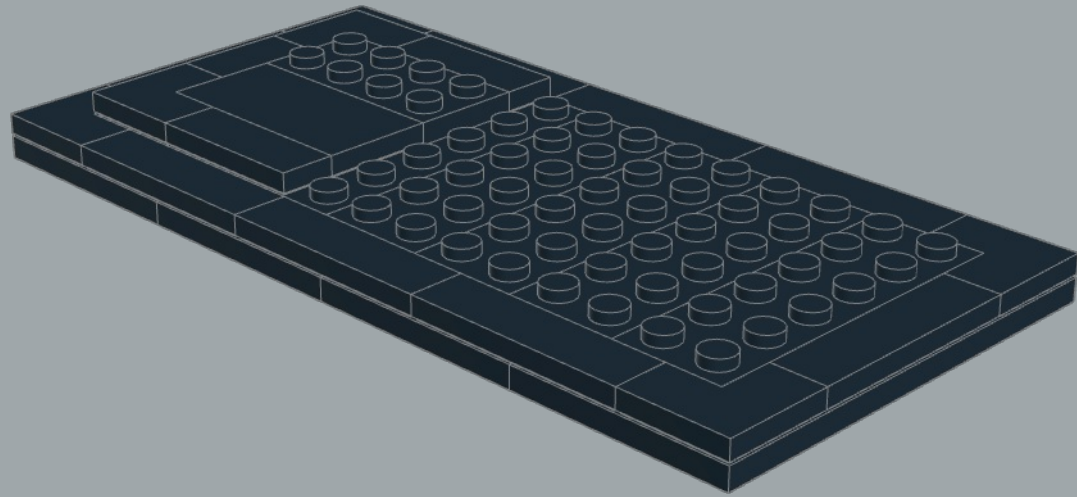

19

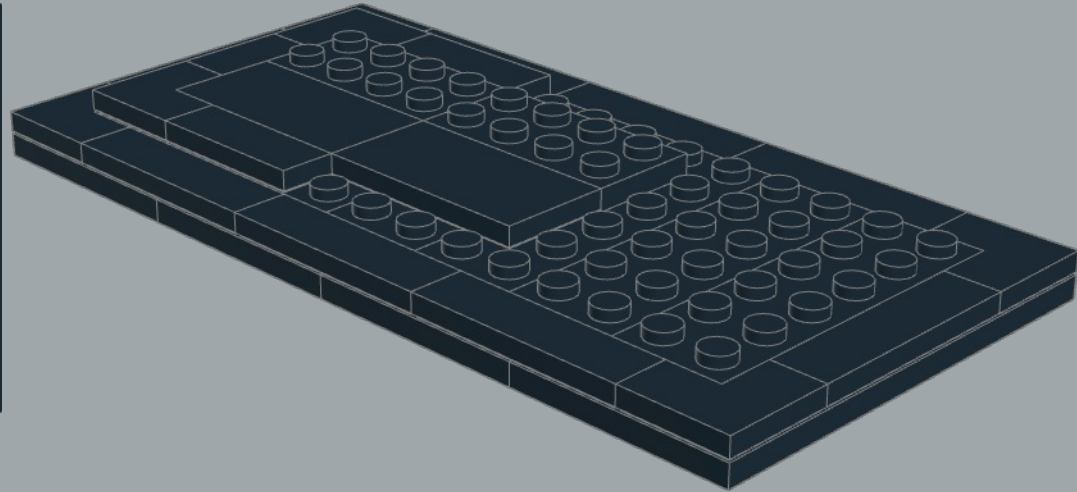
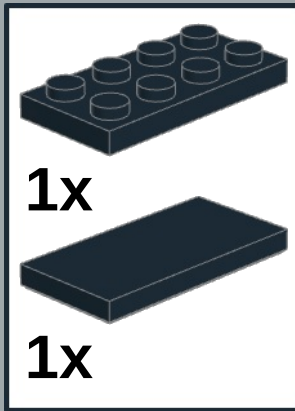

20

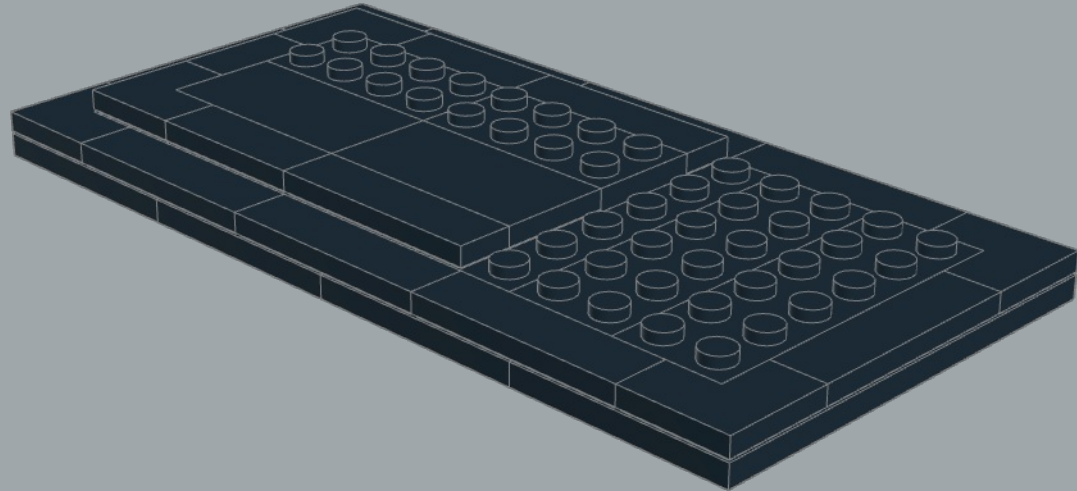
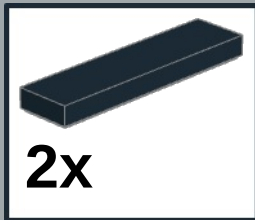

21

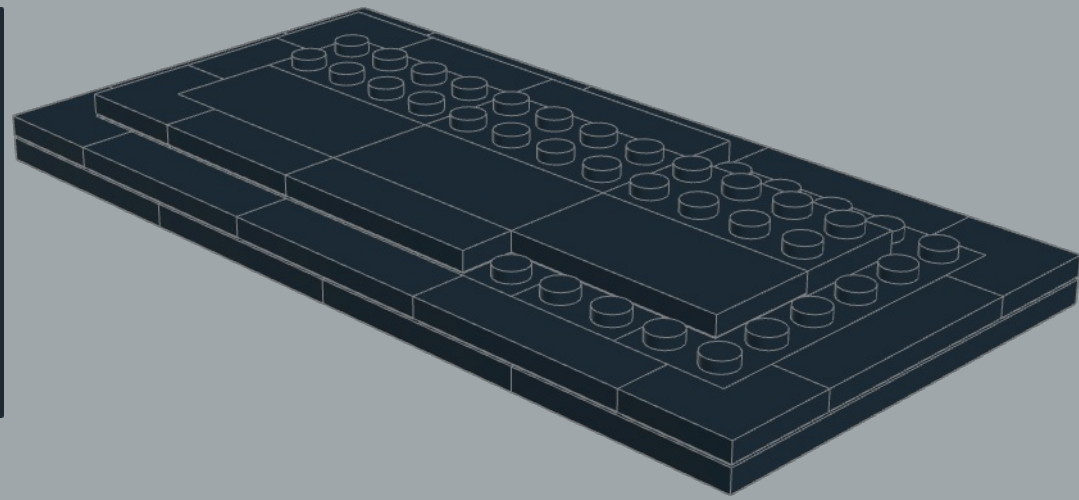
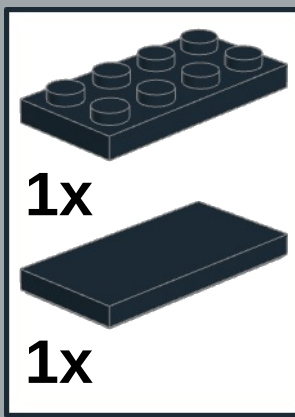

22

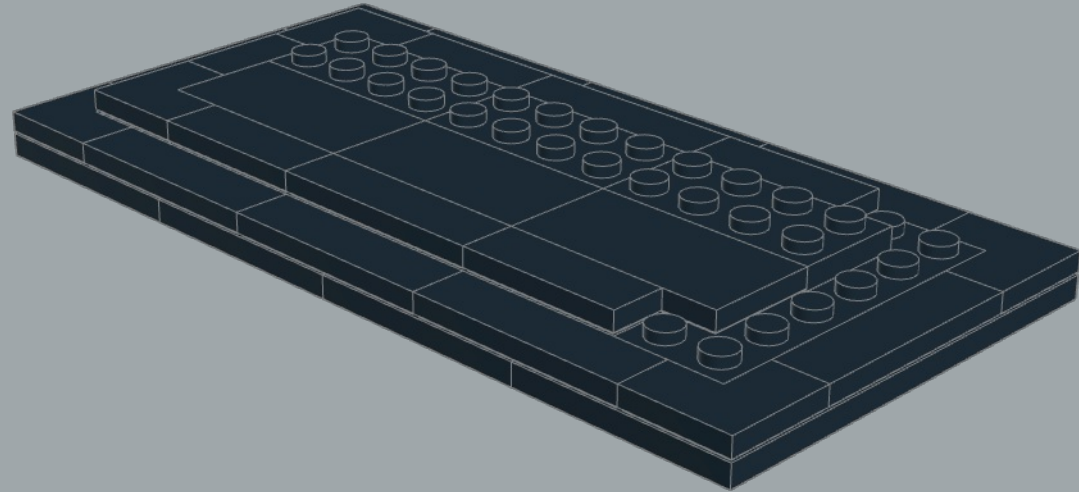

23

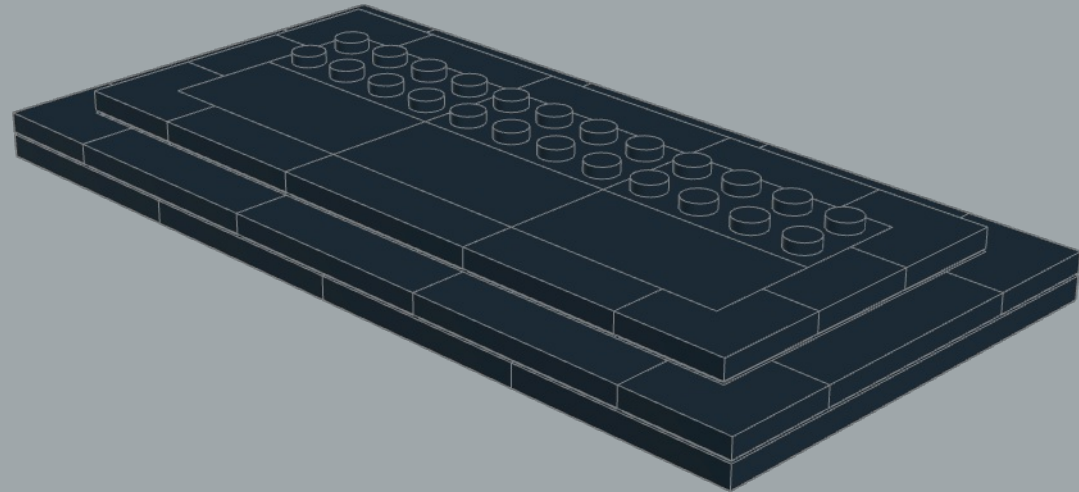
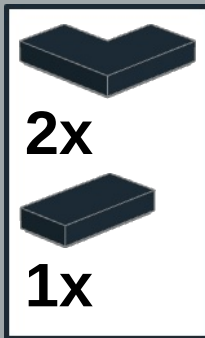

1

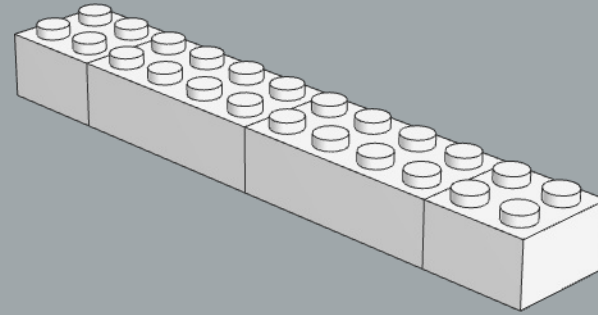
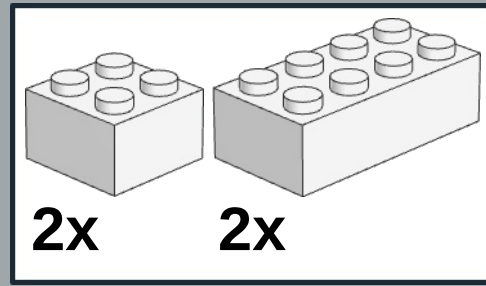

2

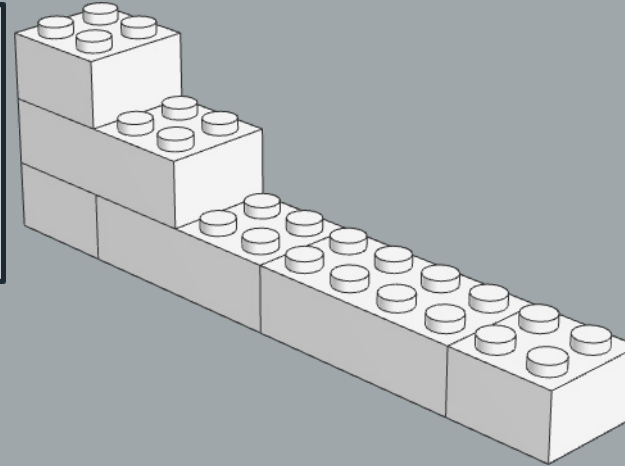
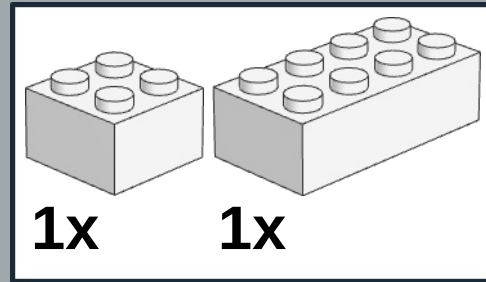

3

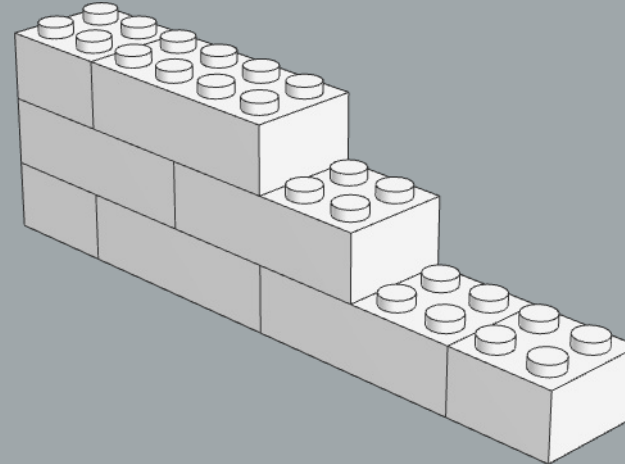
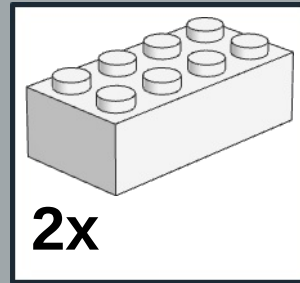

4

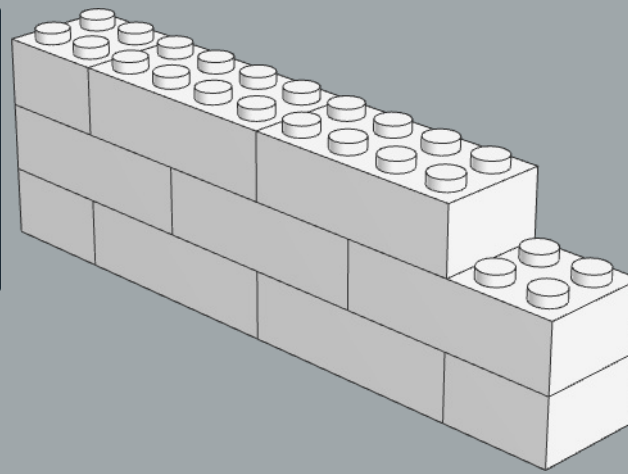
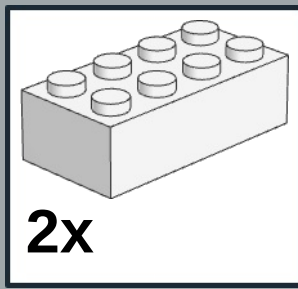

5

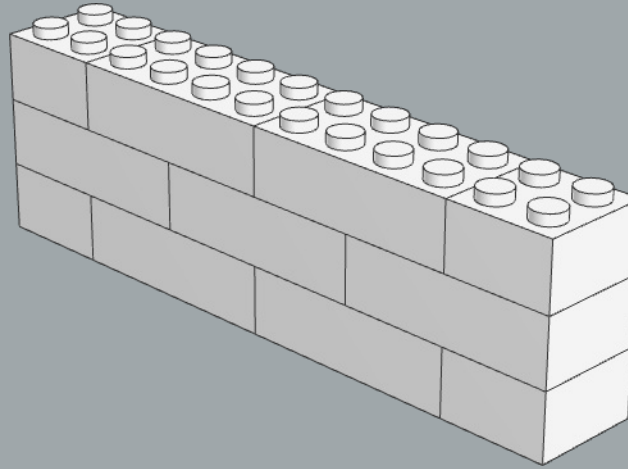
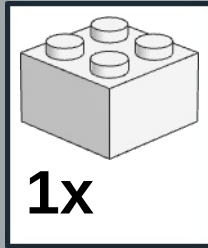

6

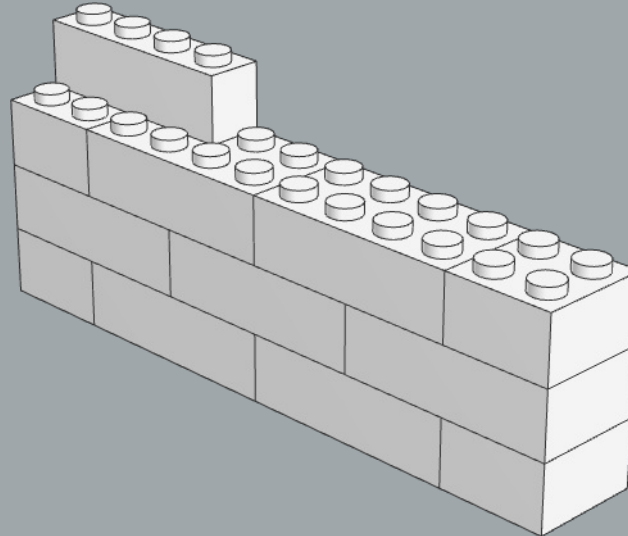
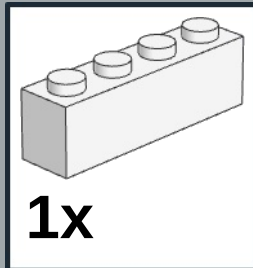

7

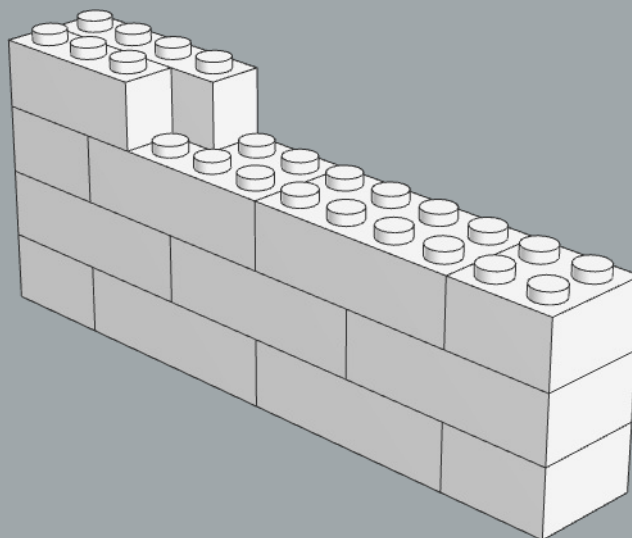
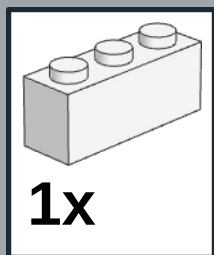

8

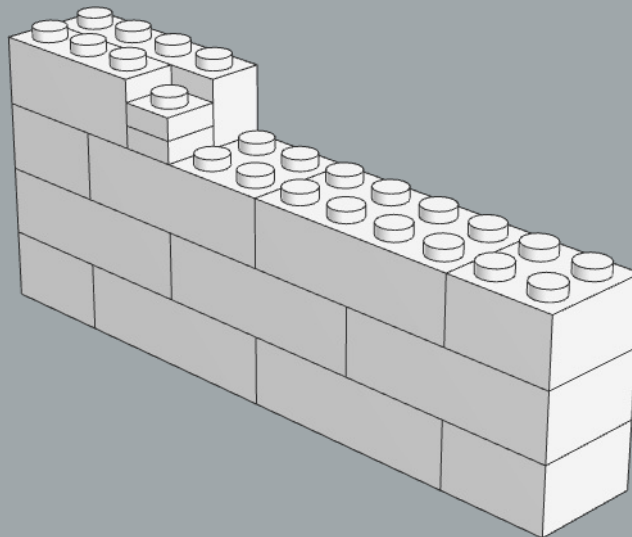
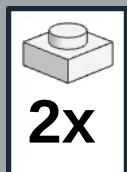

9

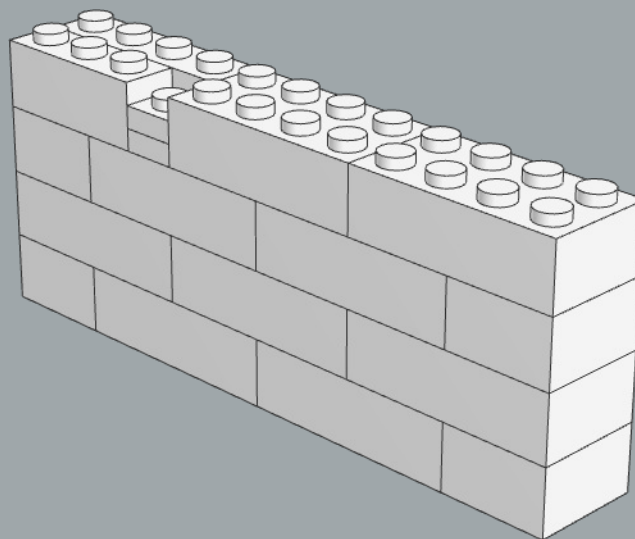
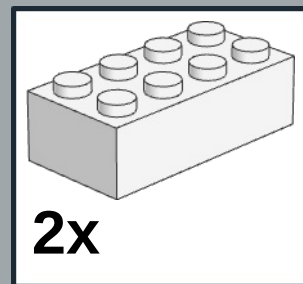

10

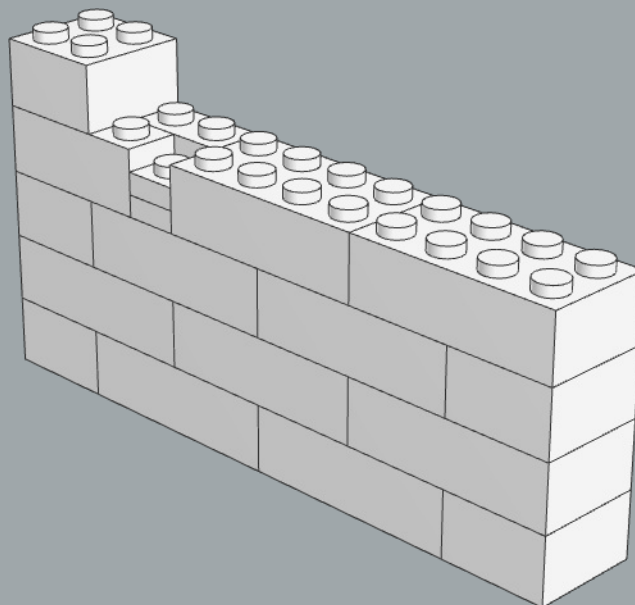
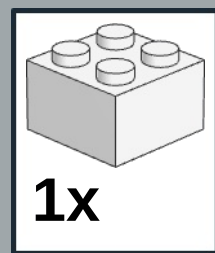

11

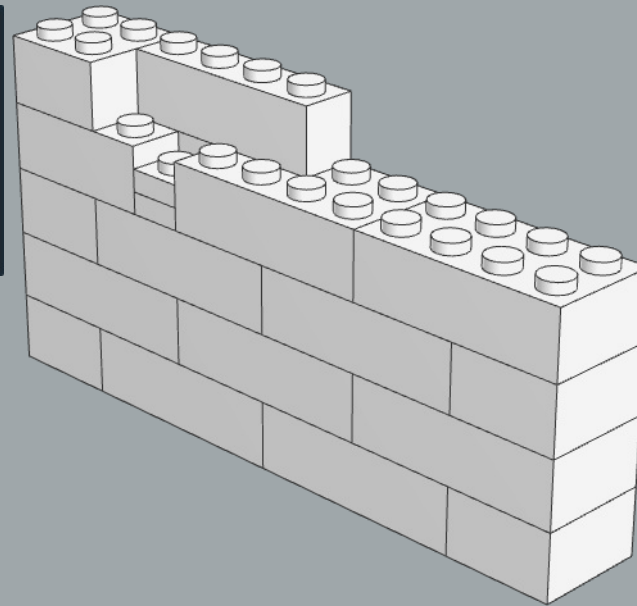
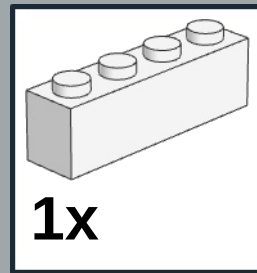

12

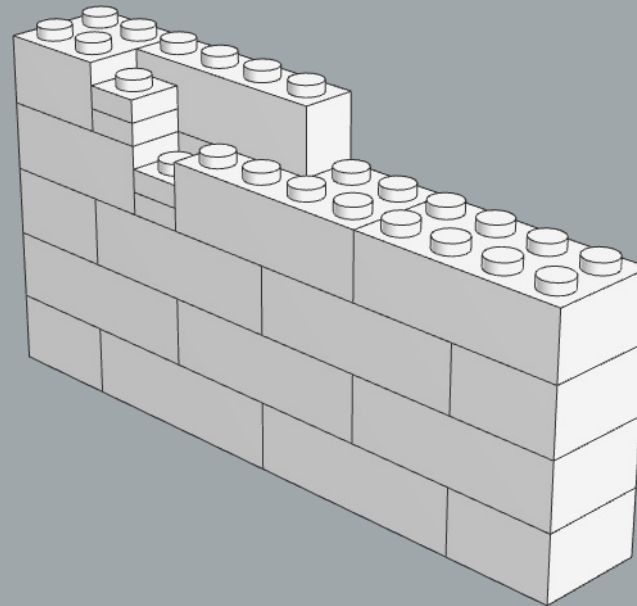
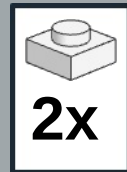



13

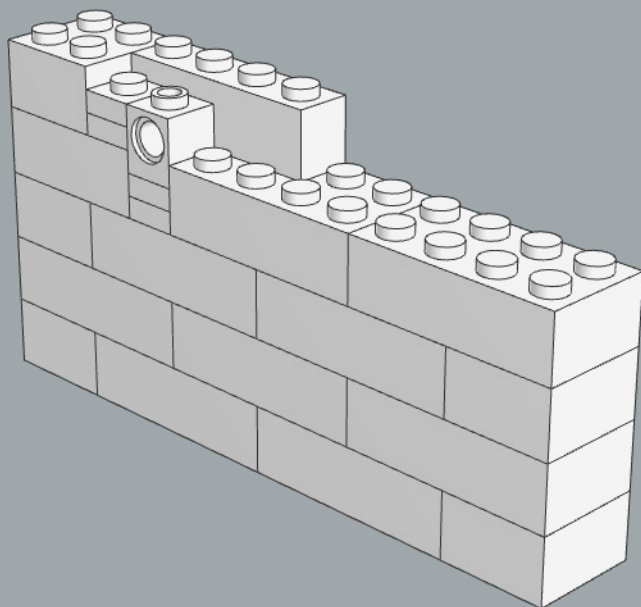
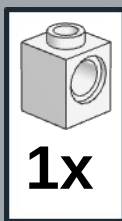

14

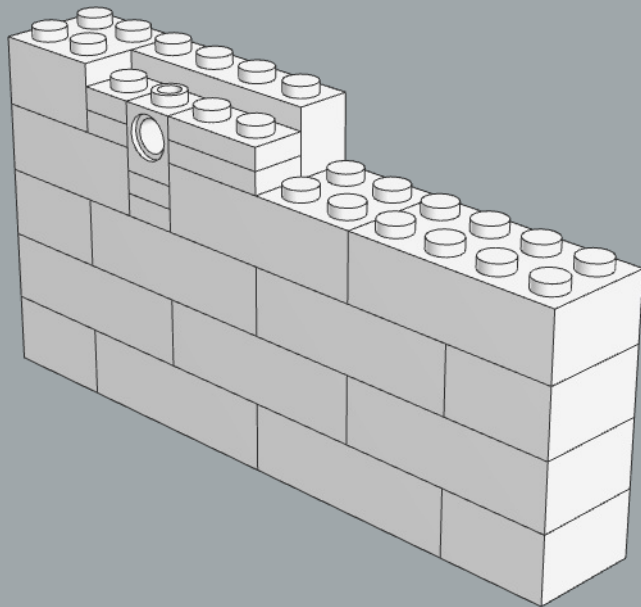
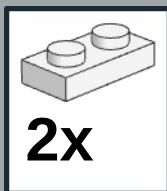

**15**

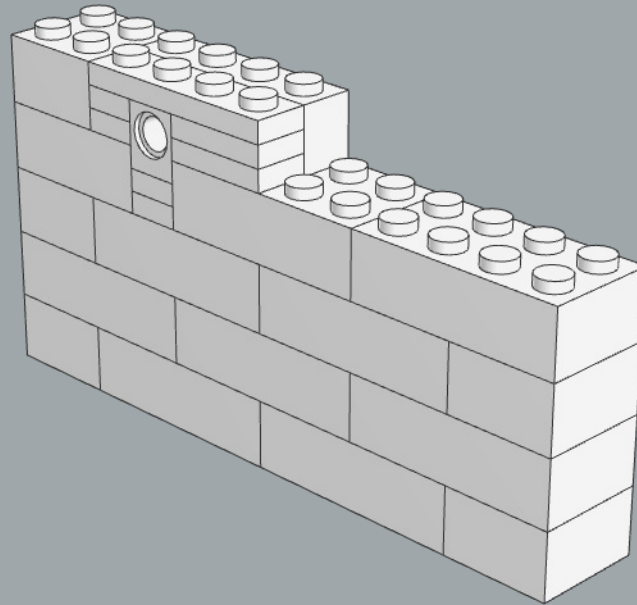
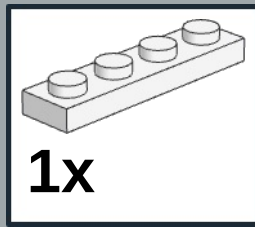

**16**

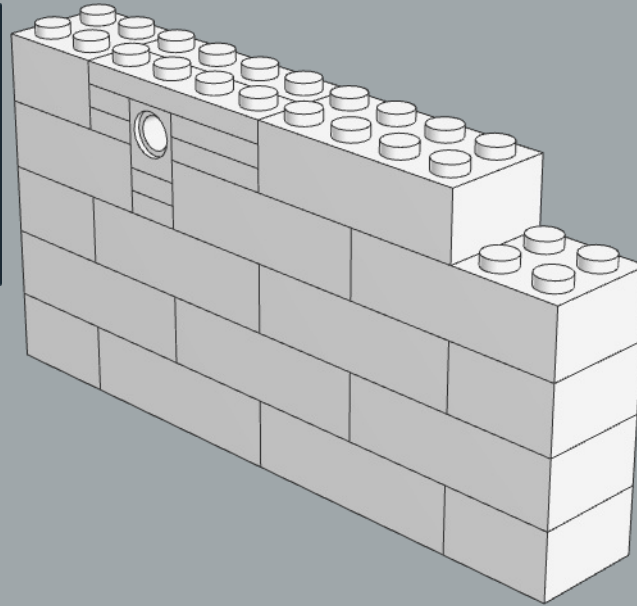
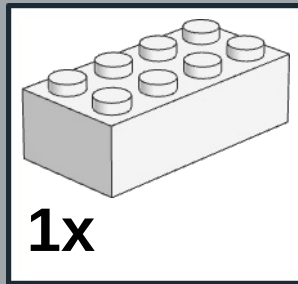

17

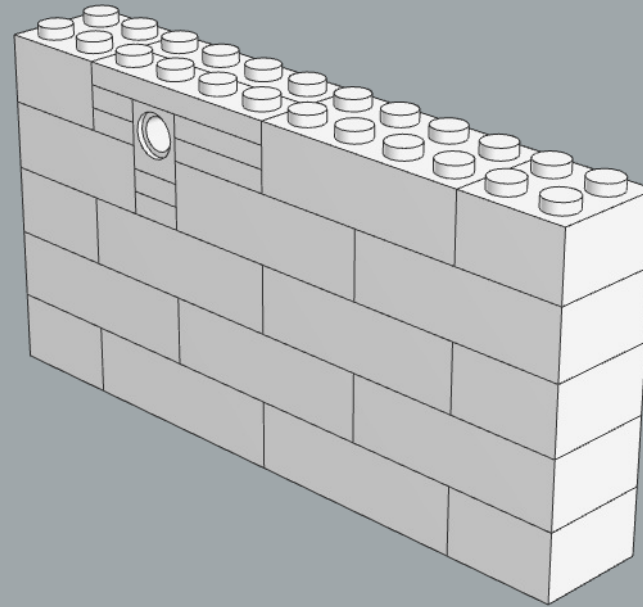
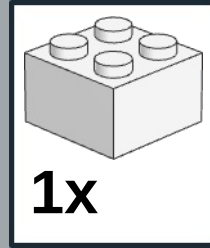

18

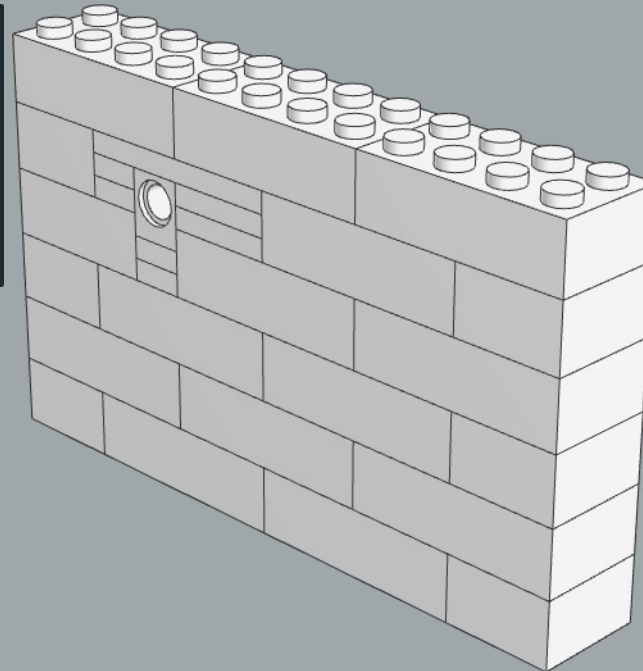
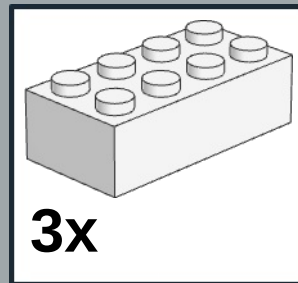

19

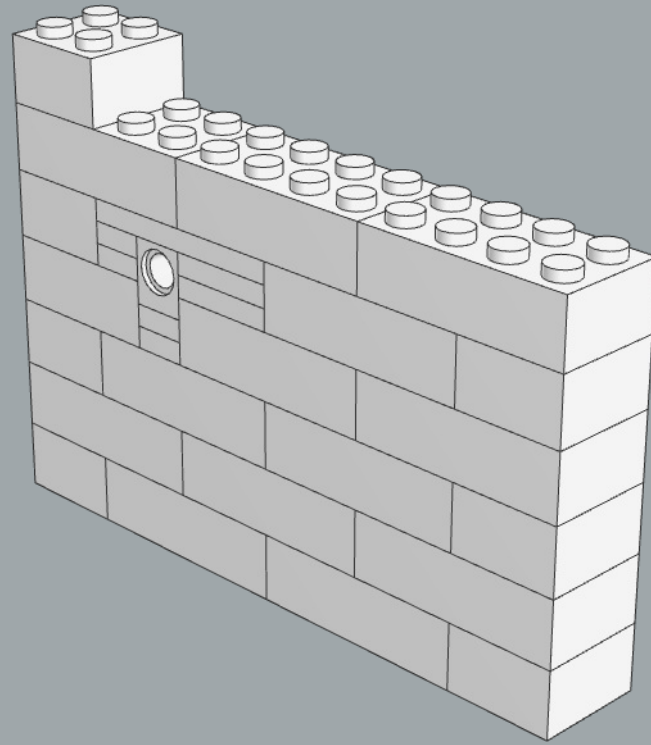
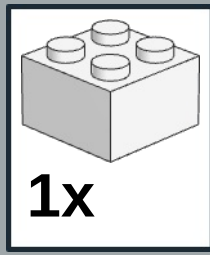

20

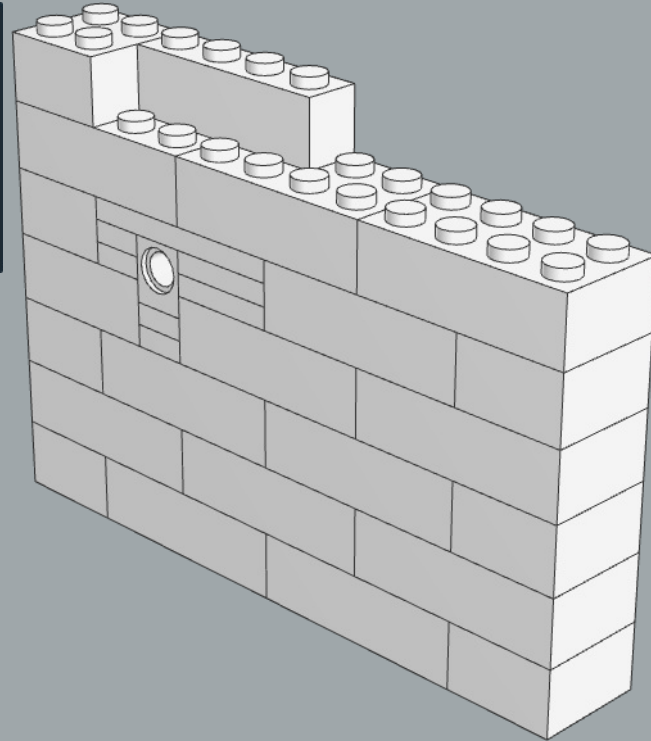
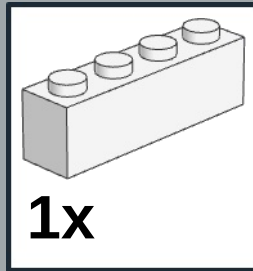

**21**

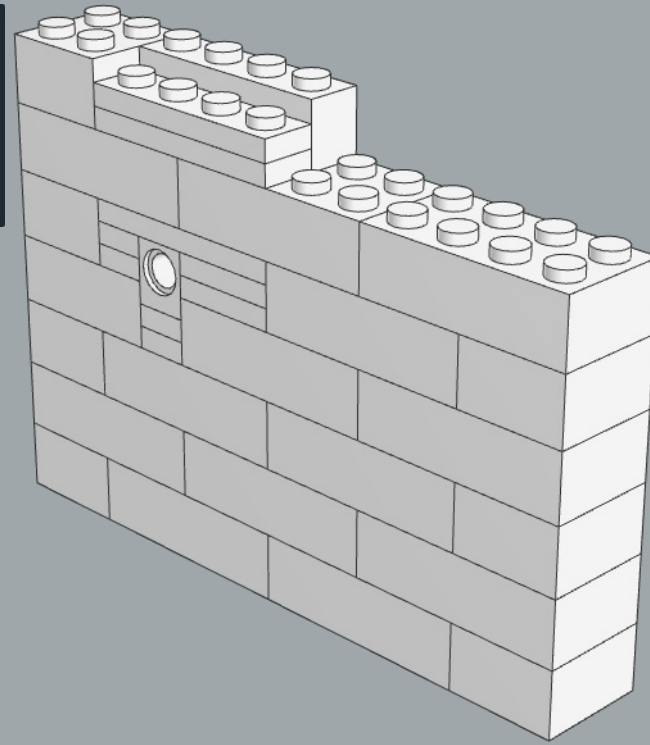
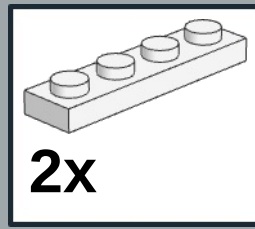

**22**

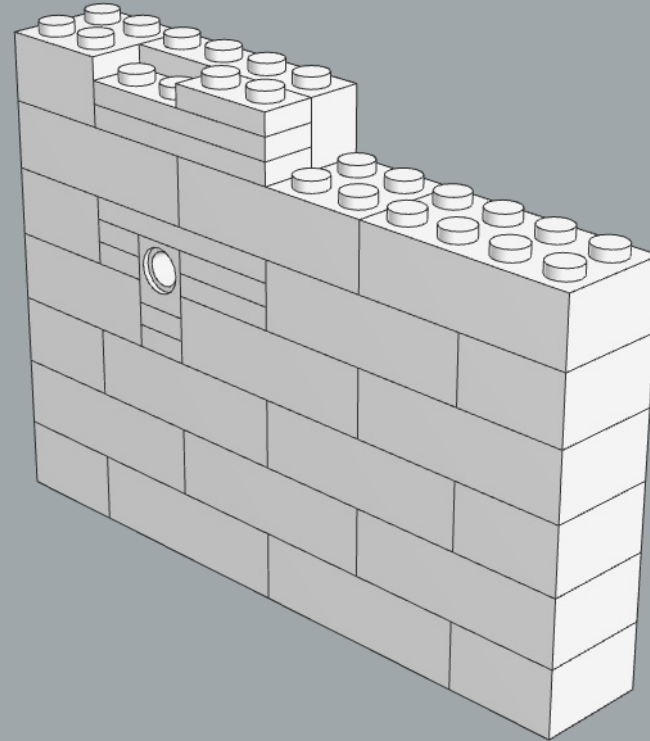
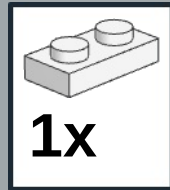

**23**

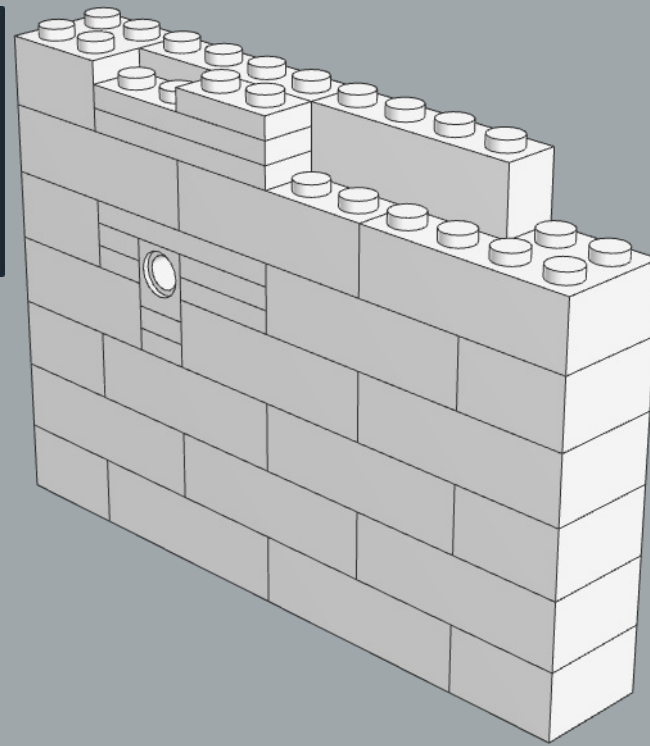
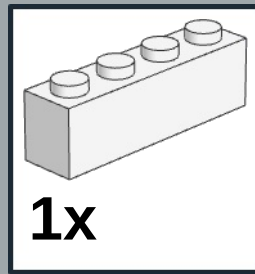

**24**

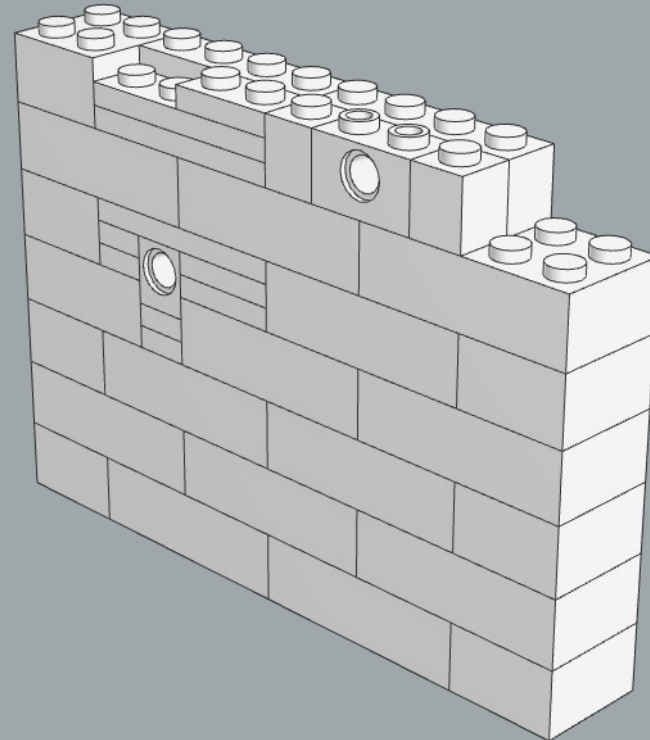
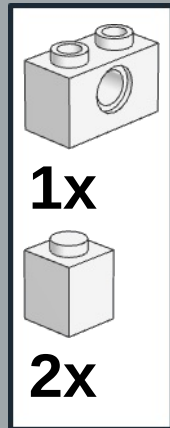

25

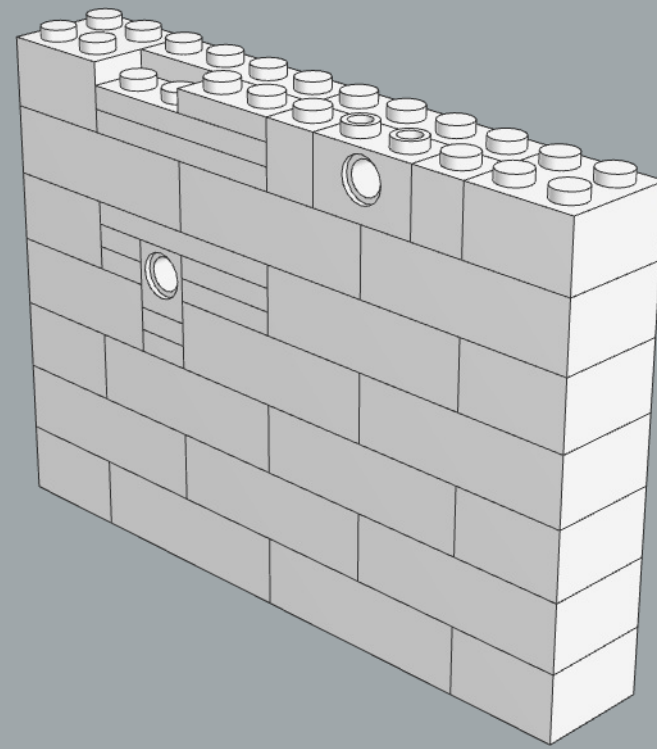
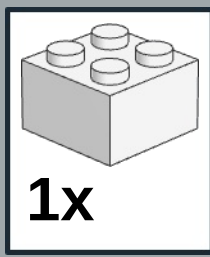

26

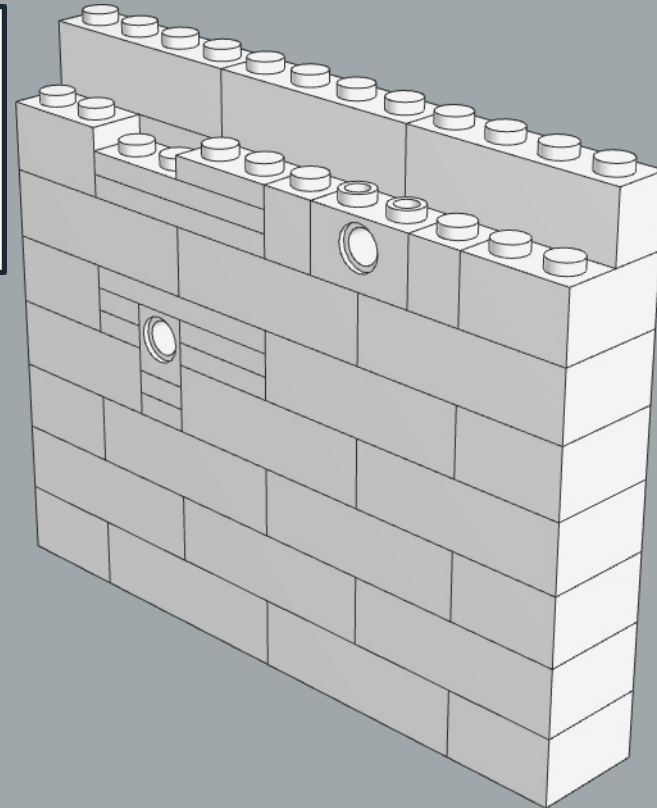
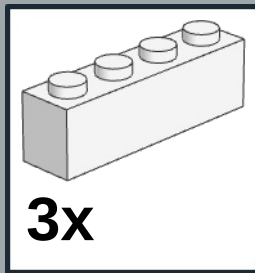

27

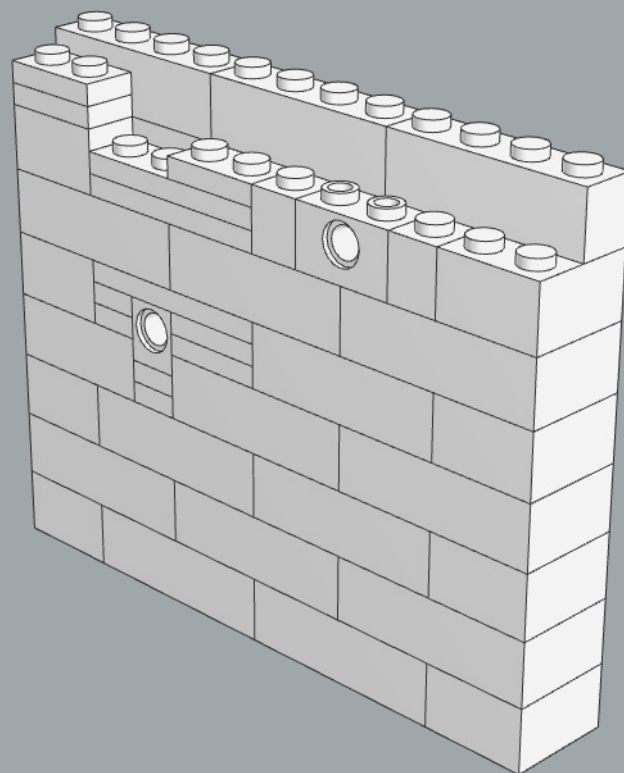
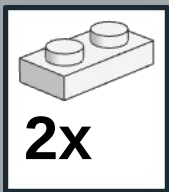



28

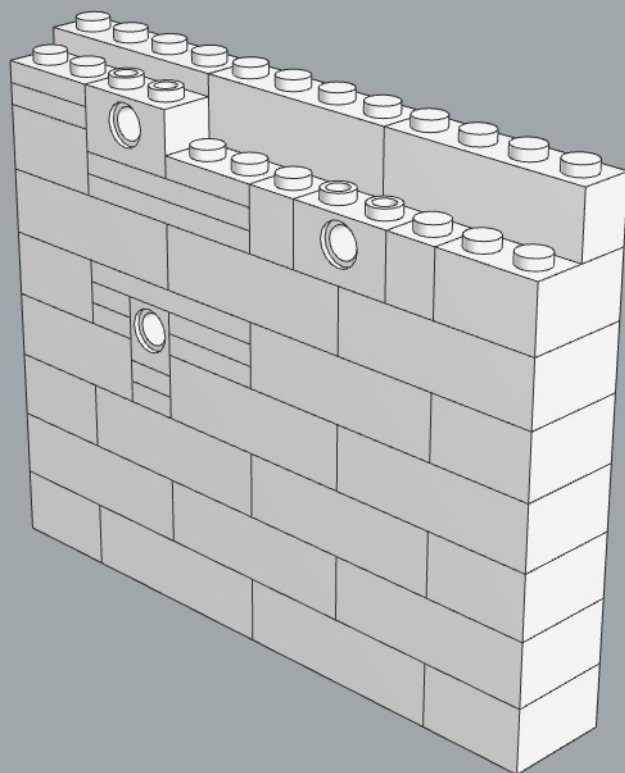
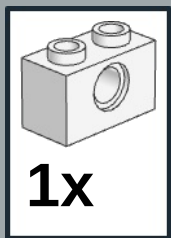

29

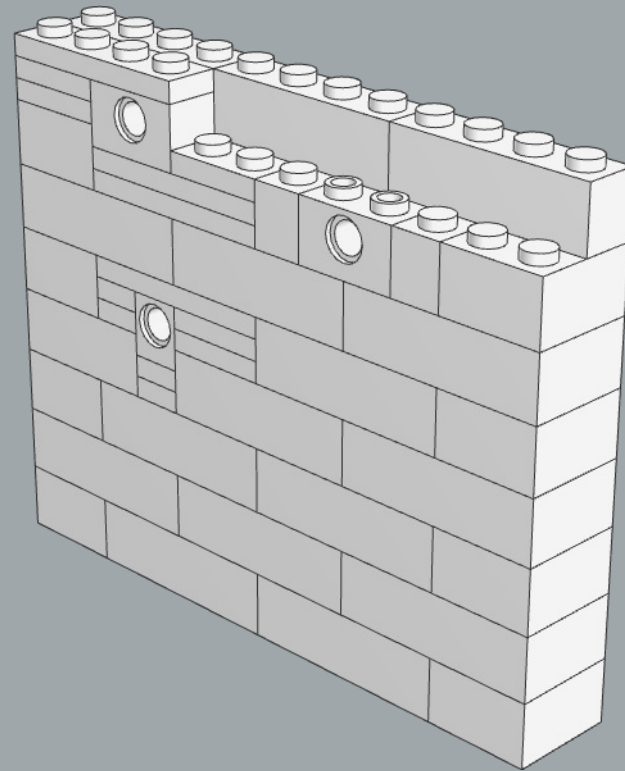
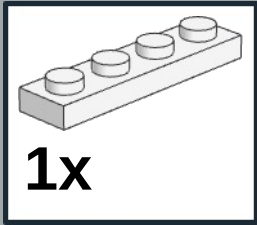

30

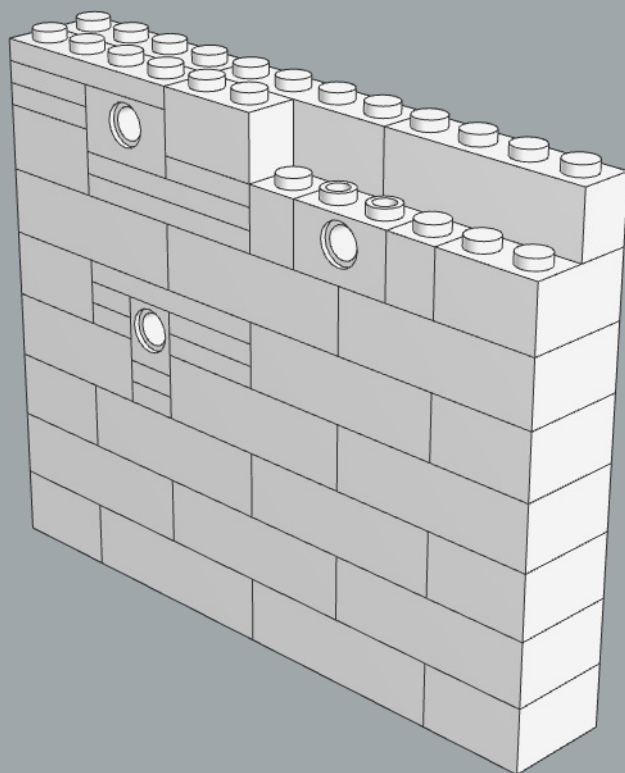
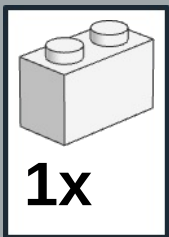

31

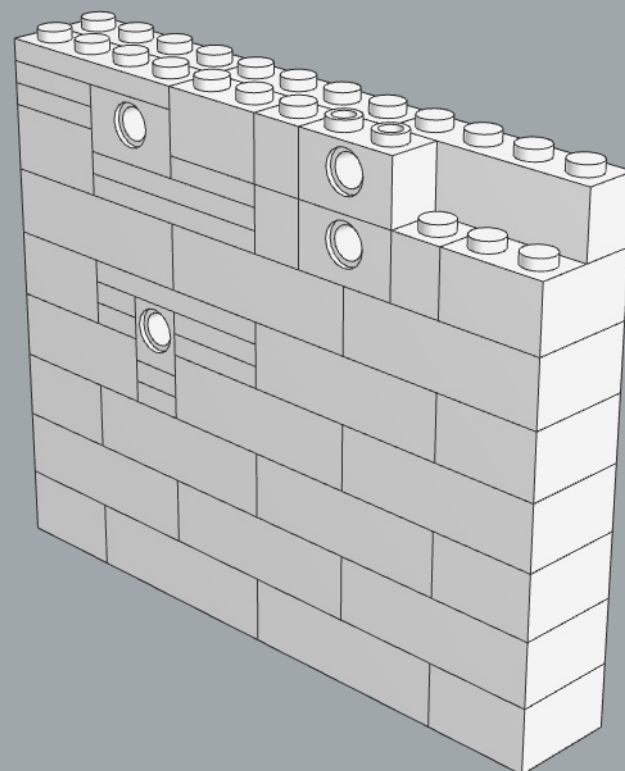
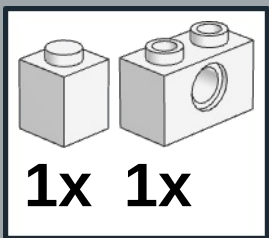

32

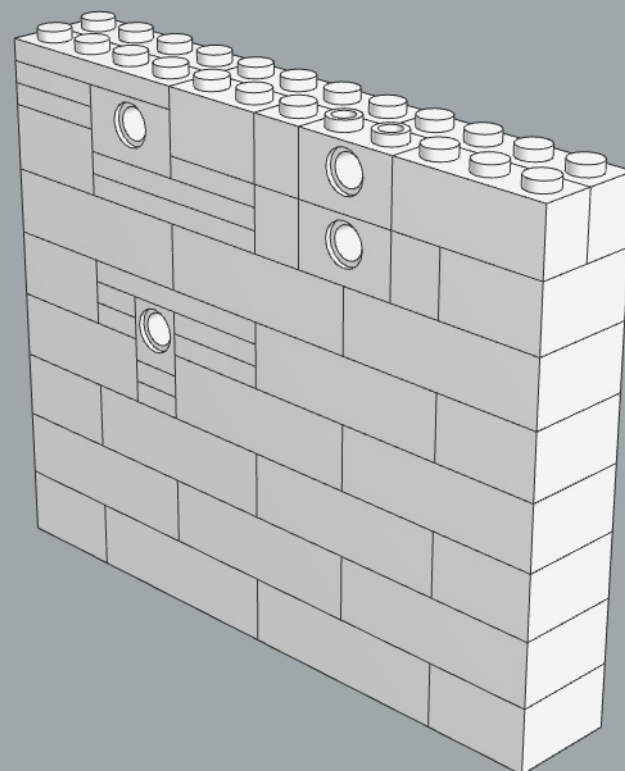
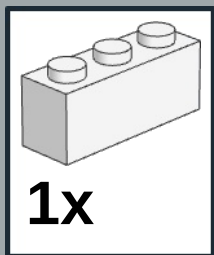

33

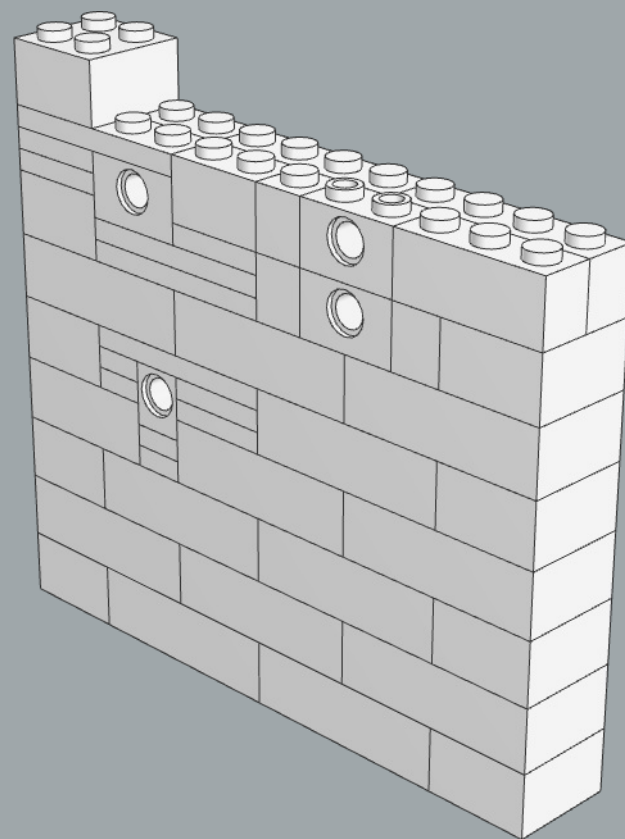
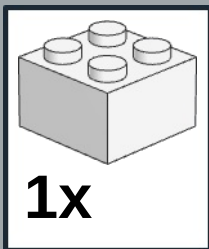

34

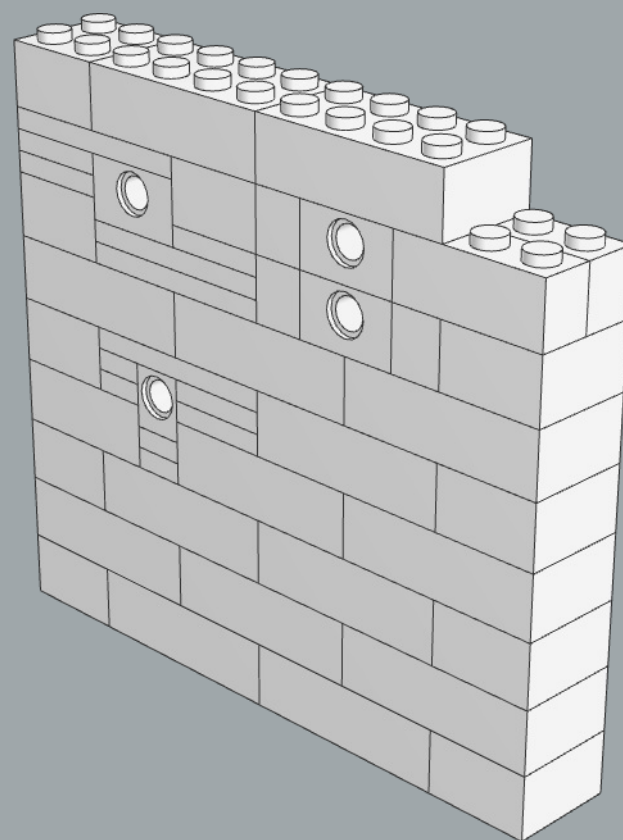
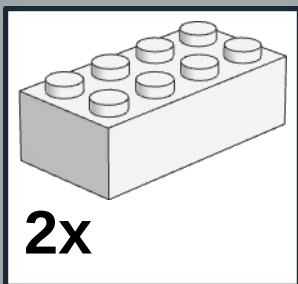

35

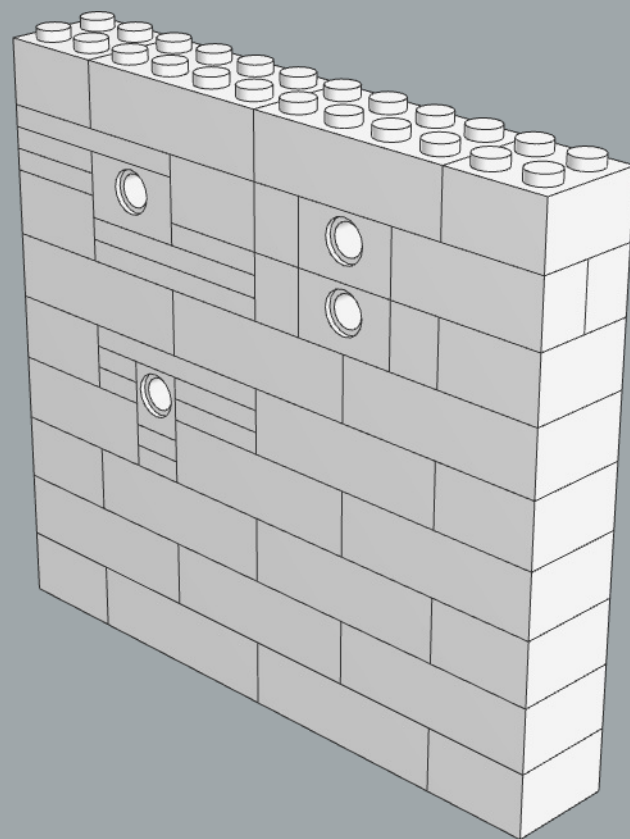
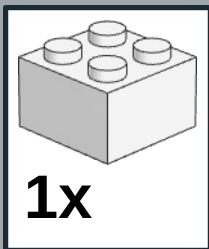



36

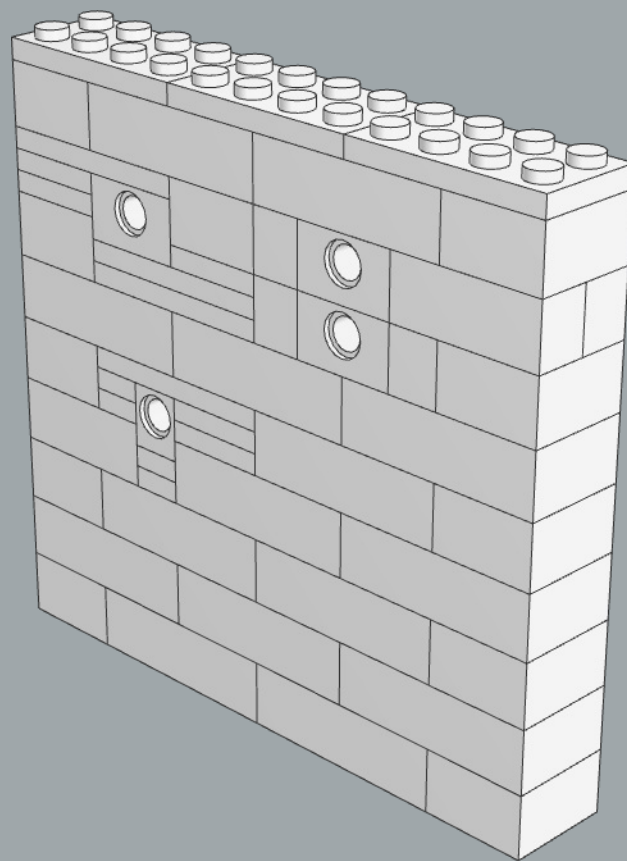
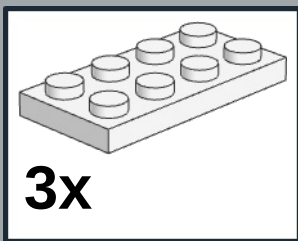

37

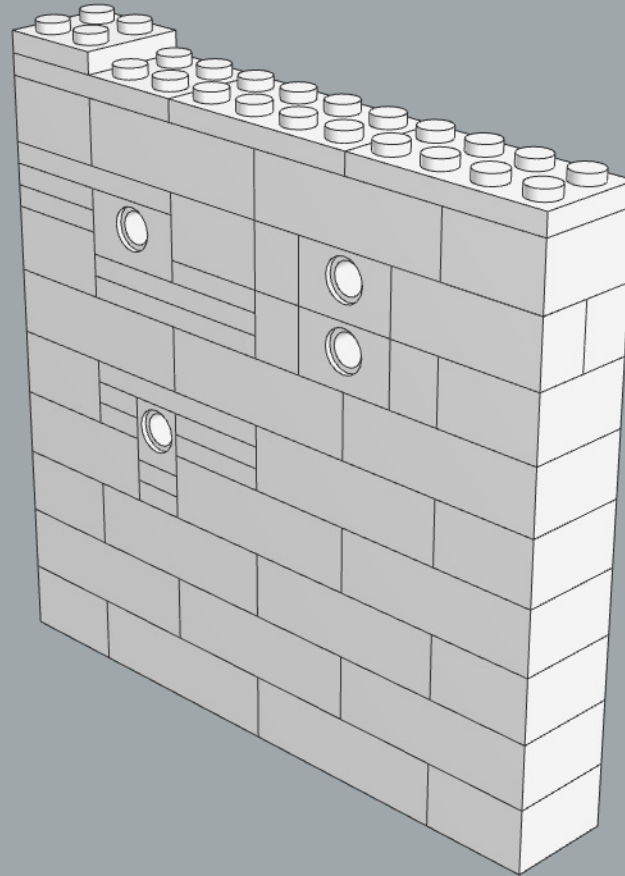
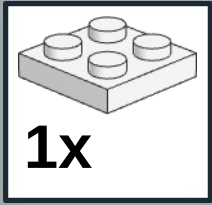

38

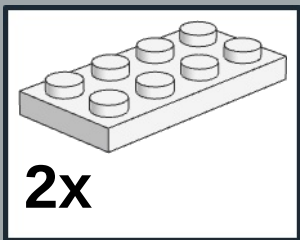

2x

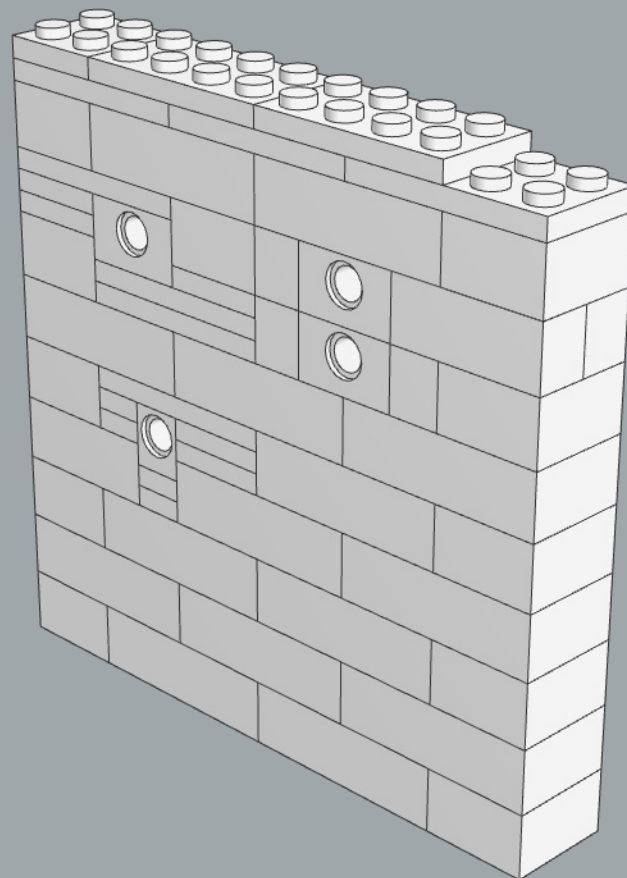

39

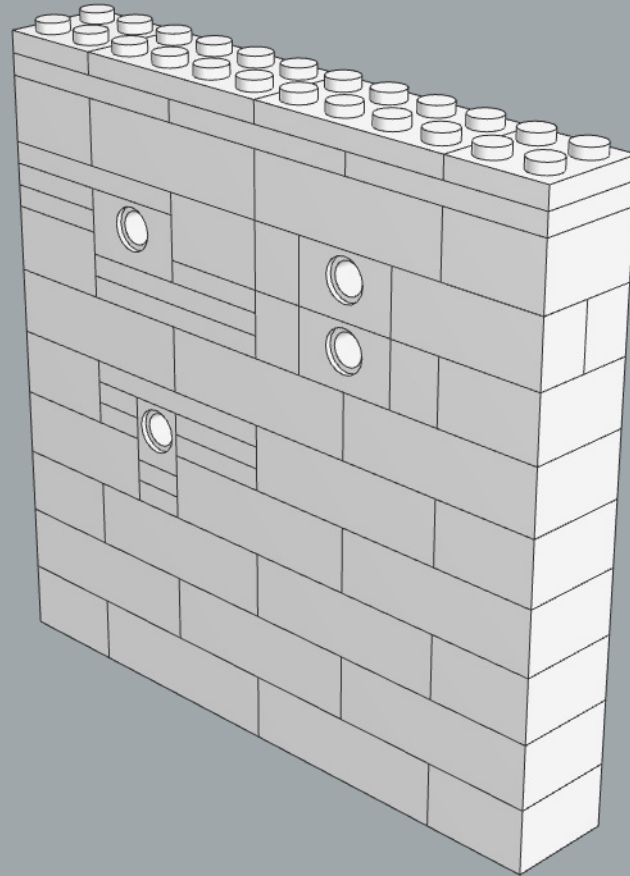
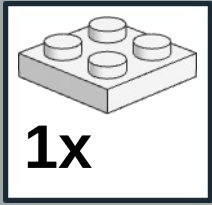

40

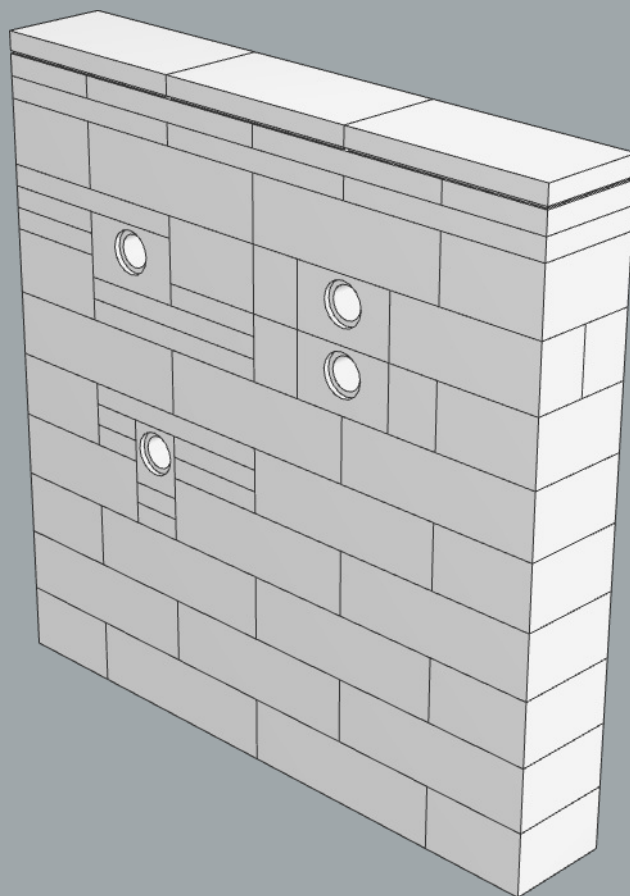
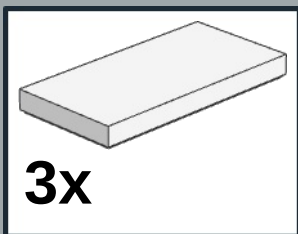

1

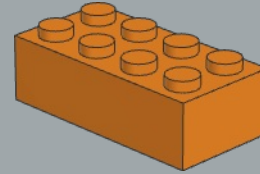
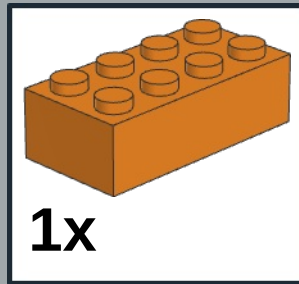

2

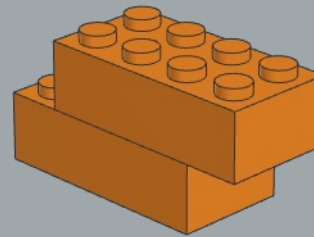
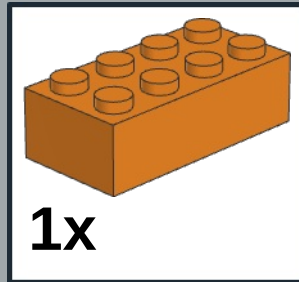

3

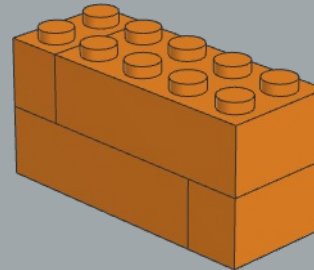
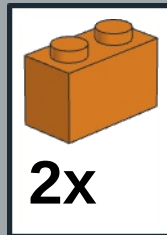

4

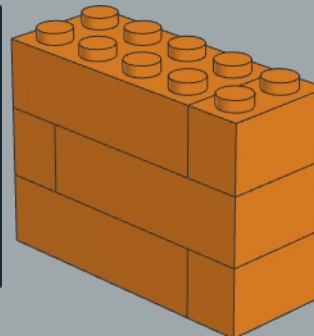
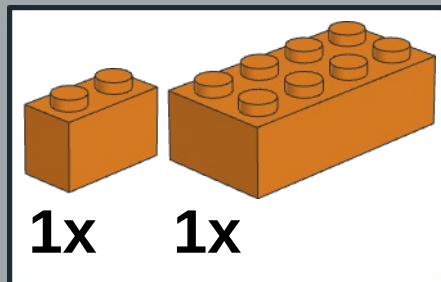

5

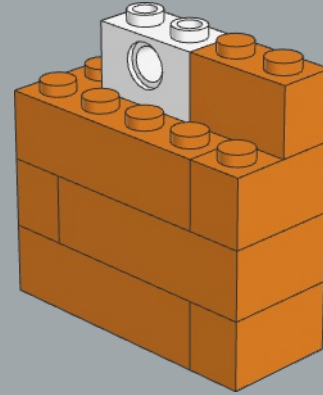
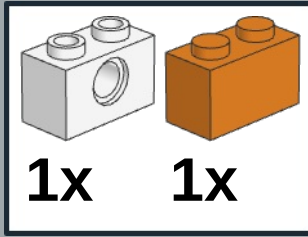

6

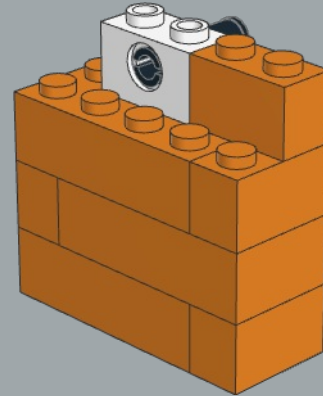

7

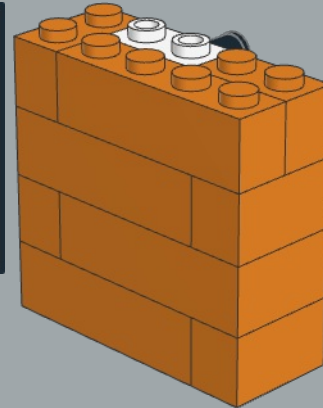
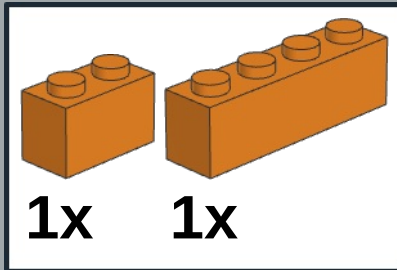

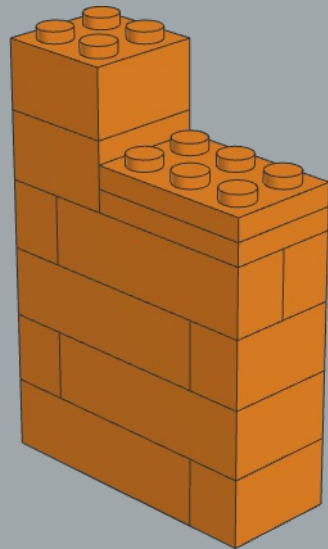
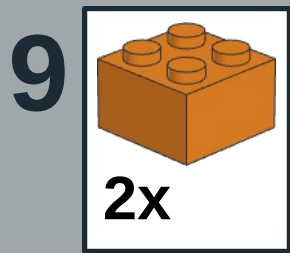
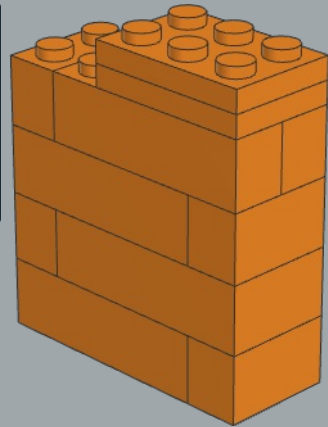
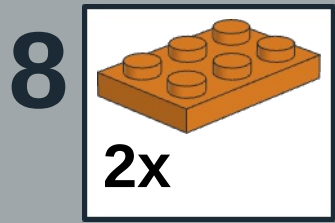

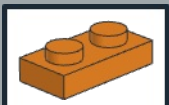

**10**  
  
**2x**

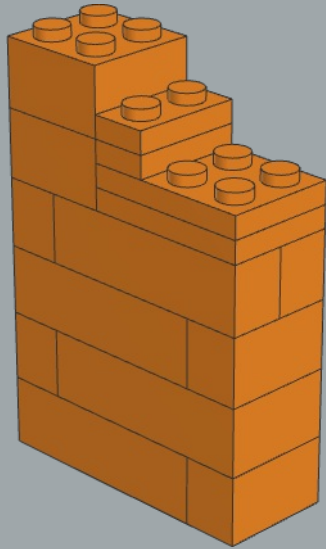

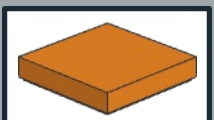
**11**  
  
**1x**

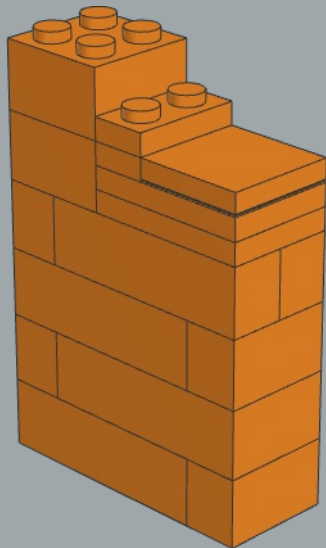

12

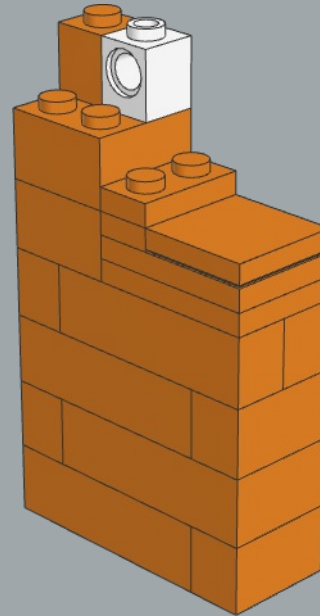
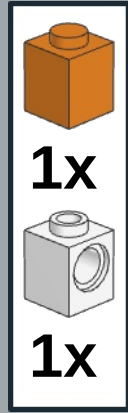

13

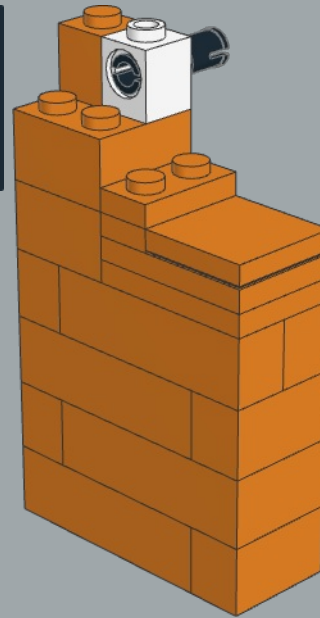

14

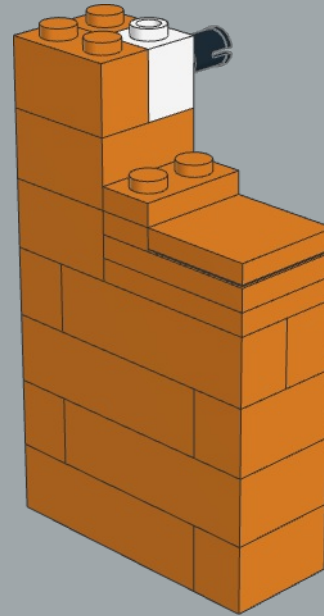
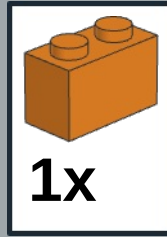

15

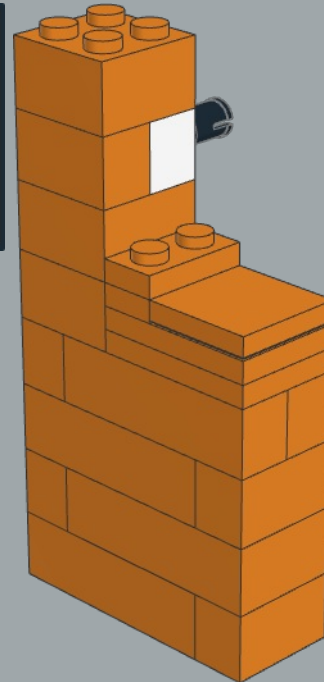
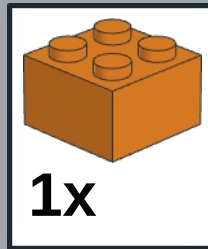

16

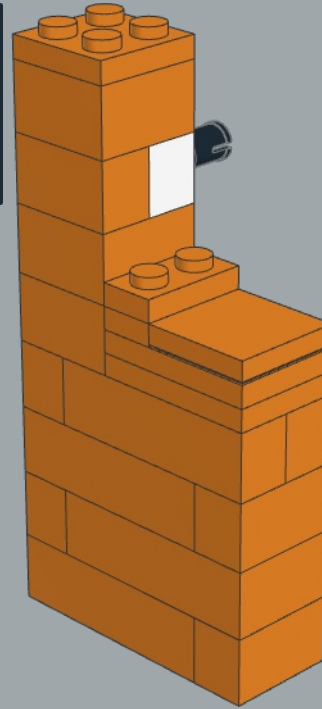
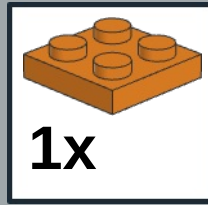

17

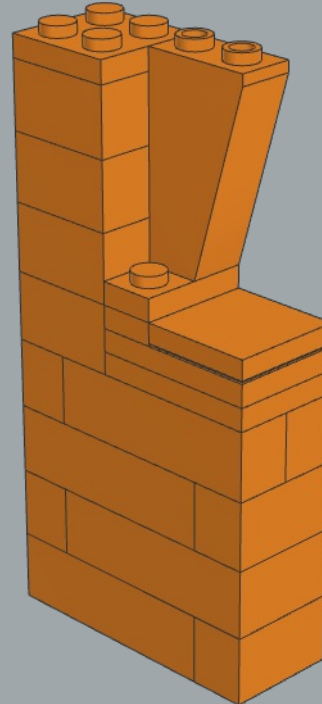
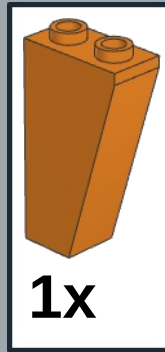

18

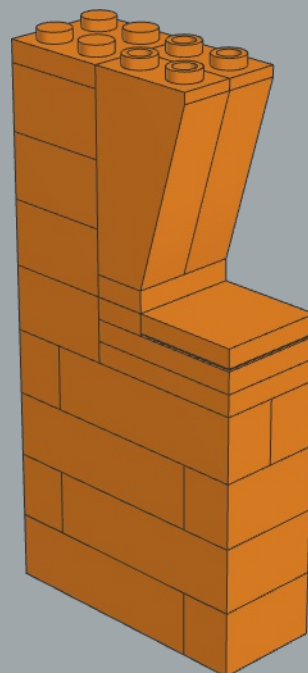
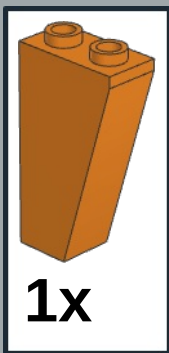

**19**

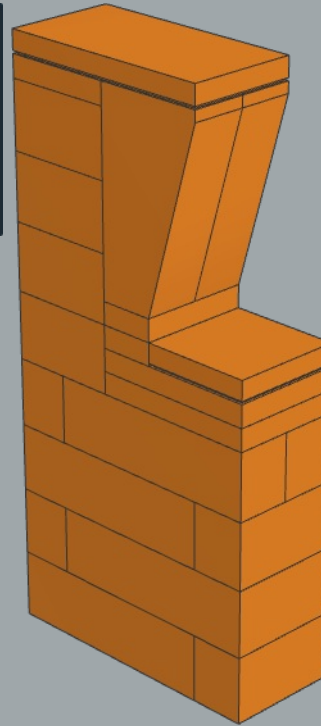
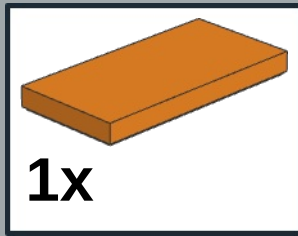

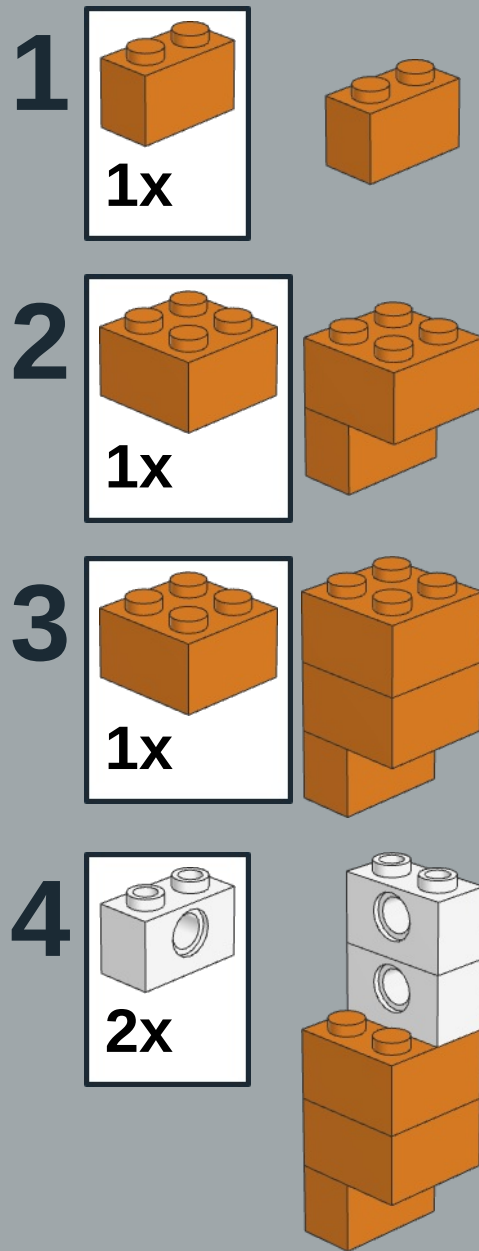

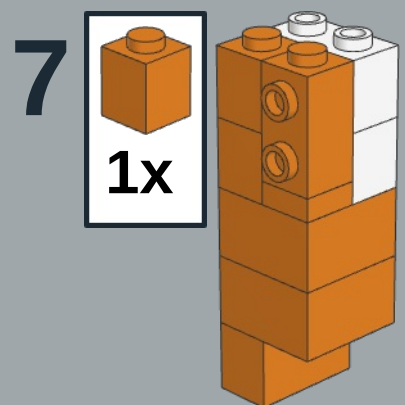
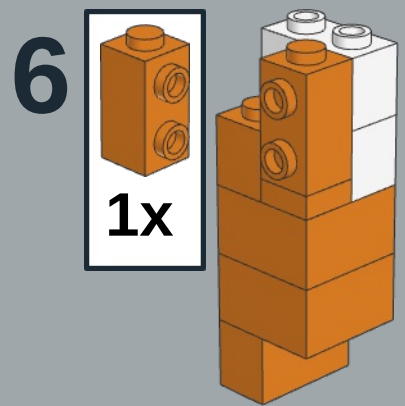
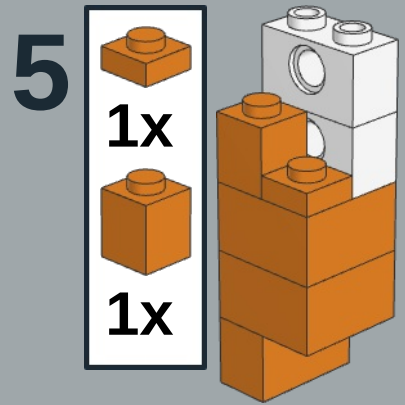



8

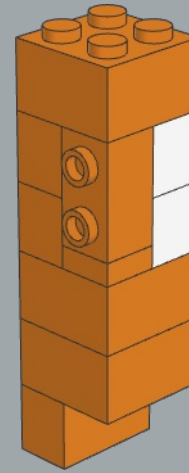
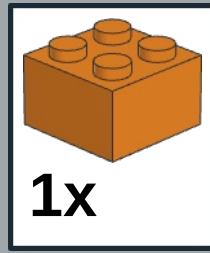

9

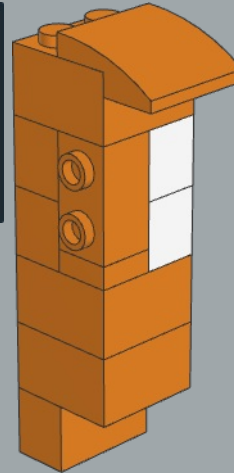
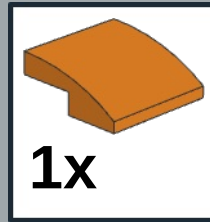

10

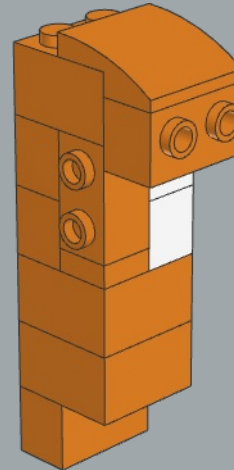
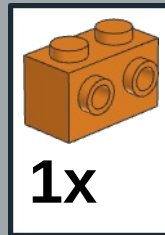

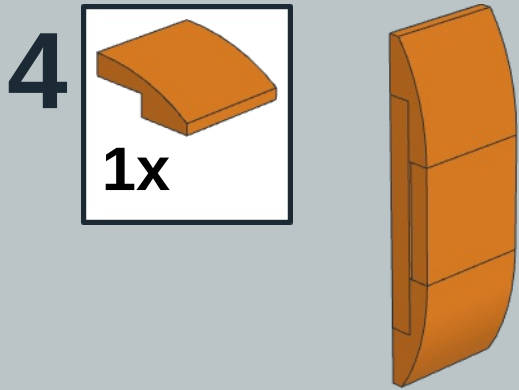
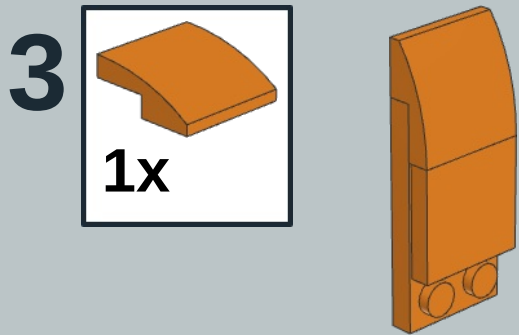
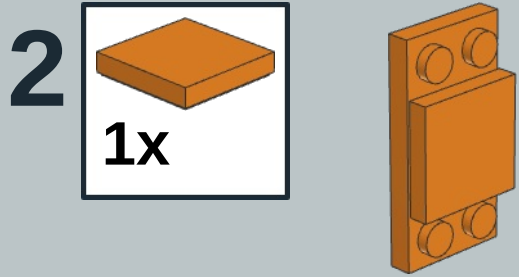
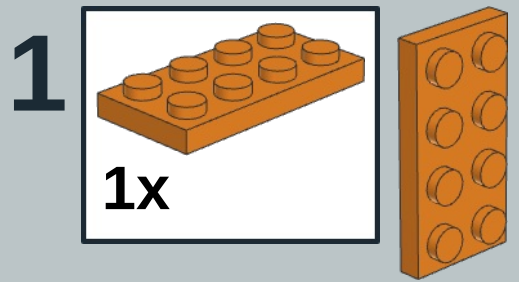

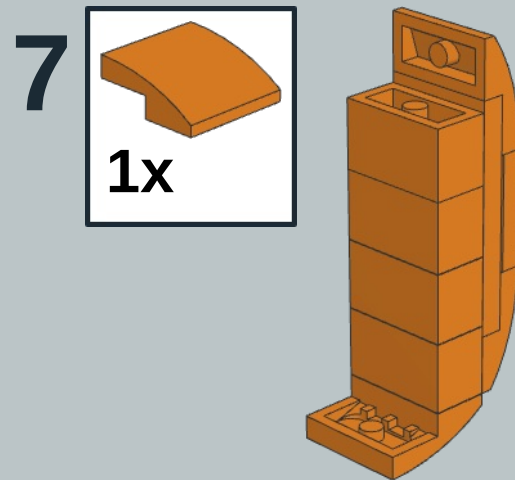
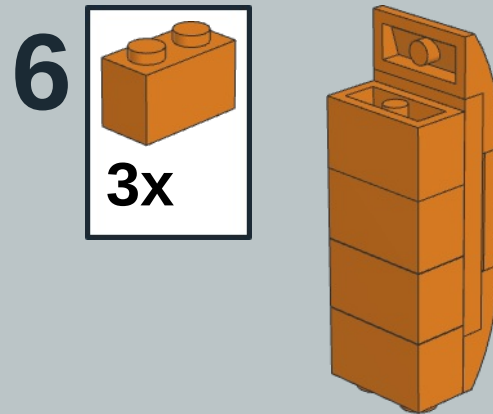
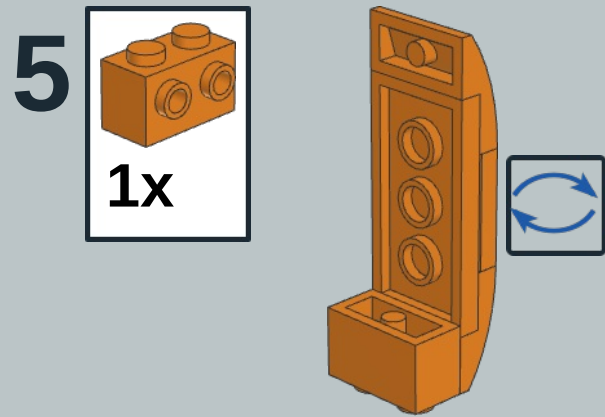

8

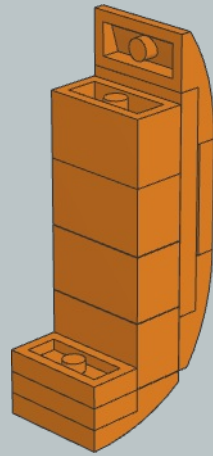
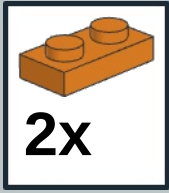

11

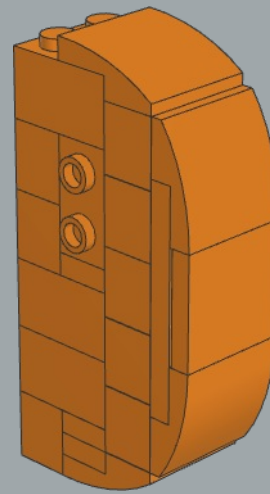

12

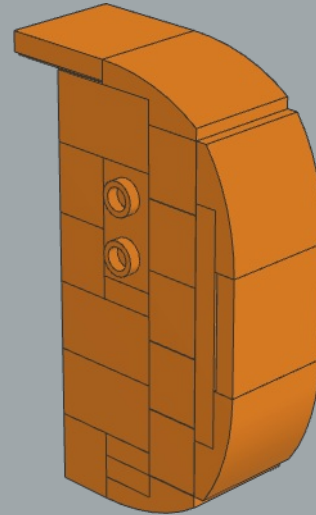
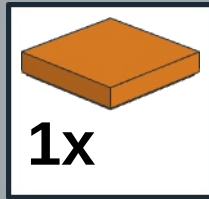

13

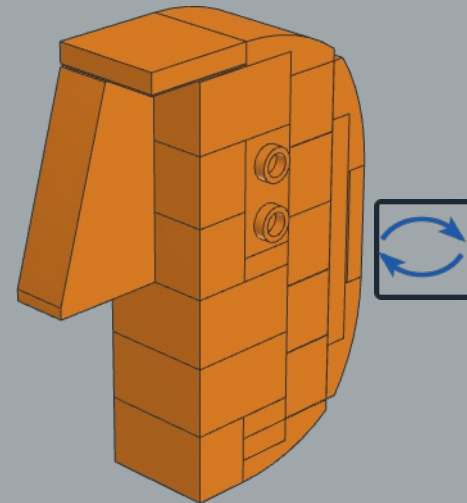
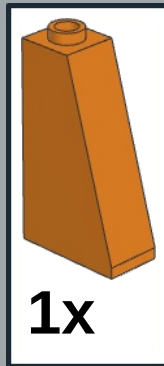

14

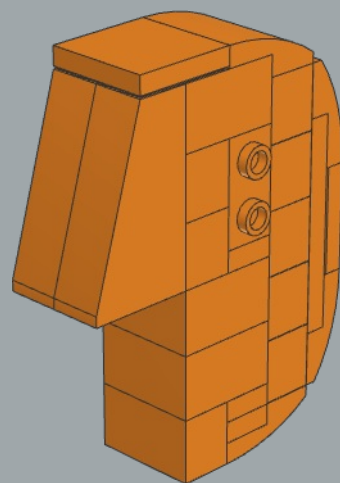
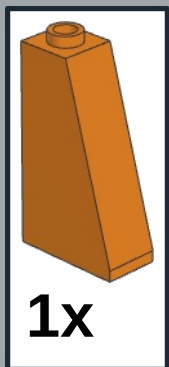

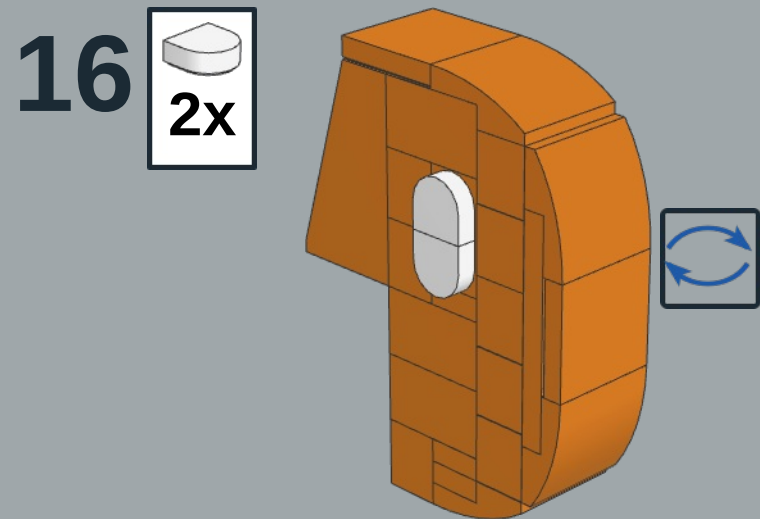
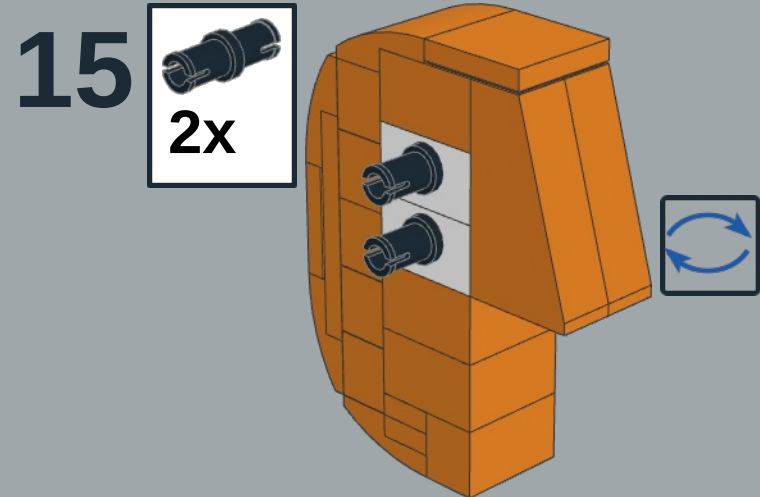

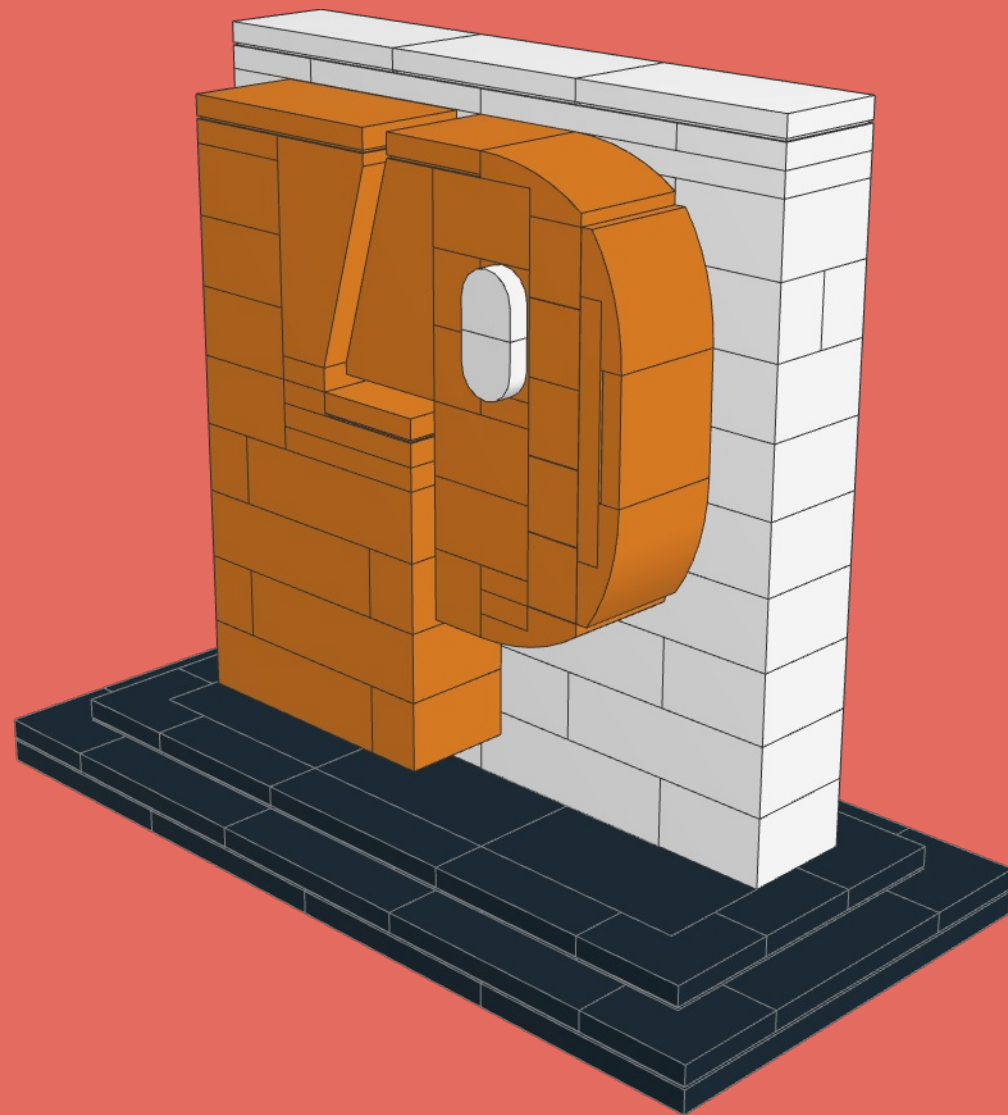



1

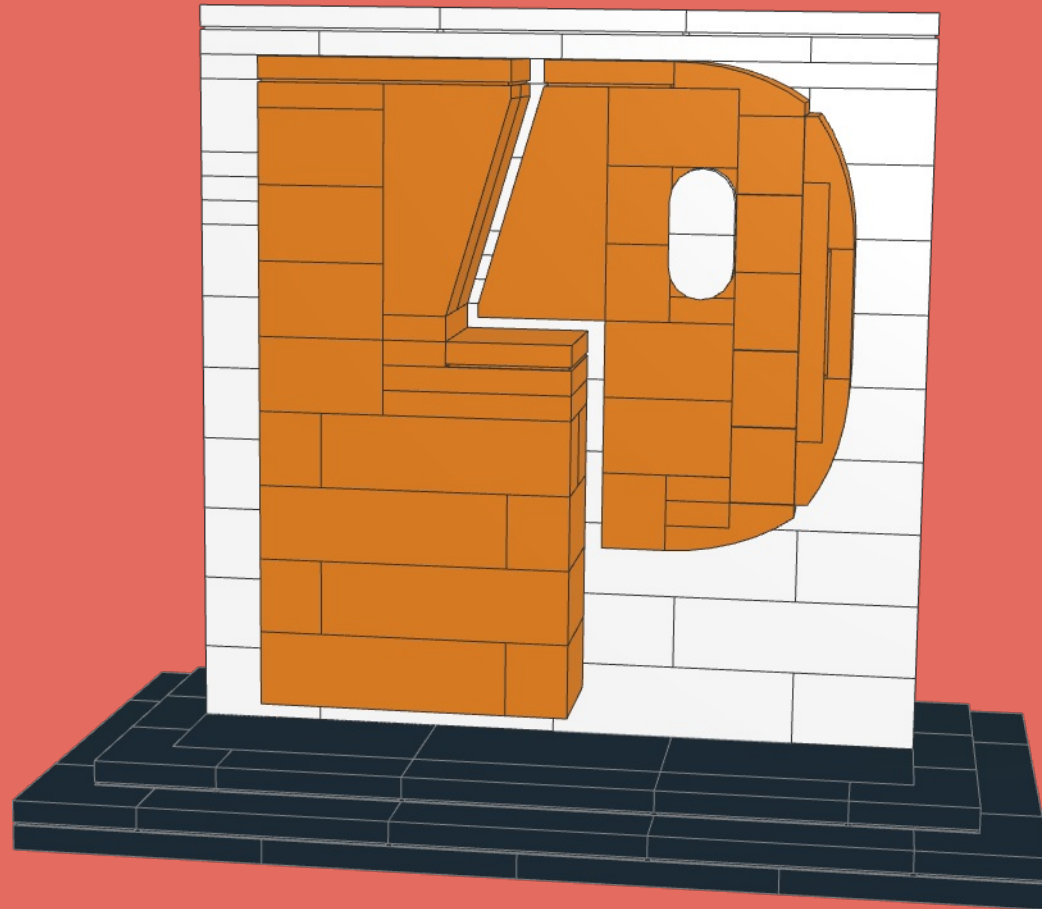

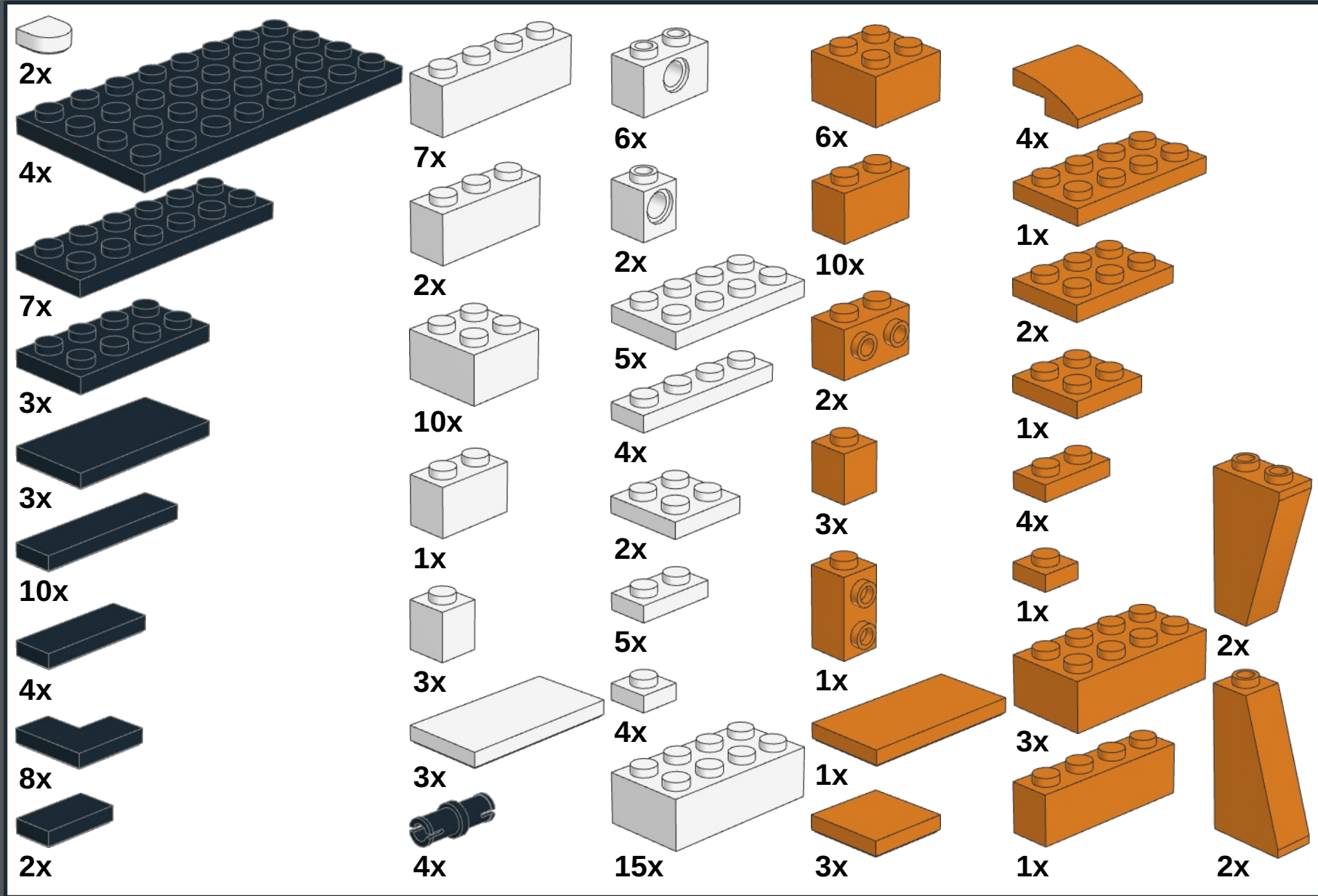

# *Honorable mentions of contributors:*

Teg12345

dalesr

csscg

Hope you had fun with this model and instructions.  
As always you can reach out to me via email:

[birdbrickbuilds@gmail.com](mailto:birdbrickbuilds@gmail.com)

You can also check my work on rebrickable and  
instagram:

<https://rebrickable.com/users/birdbrickbuilds/>

<https://www.instagram.com/birdbrickbuilds/>

If you wish to help me continue to make this  
models and instructions you can buy me a coffee  
to help me stay up late:

<https://www.buymeacoffee.com/birdbrickbl>

Or you can buy my Coffee Espresso MOC:

<https://reb.li/m/118798>



This work is licensed under a [Creative Commons Attribution-NonCommercial-ShareAlike 4.0 International License](https://creativecommons.org/licenses/by-nc-sa/4.0/).