

# Mother's Day



Model instructions by Bird Brick Builds

Author: Eduardo Sousa

312 Parts





# Attribution-NonCommercial-ShareAlike 4.0 International (CC BY-NC-SA 4.0)

This is a human-readable summary of (and not a substitute for) the [license](#). [Disclaimer](#).

## You are free to:

**Share** — copy and redistribute the material in any medium or format

**Adapt** — remix, transform, and build upon the material

The licensor cannot revoke these freedoms as long as you follow the [license terms](#).

---

## Under the following terms:



**Attribution** — You must give [appropriate credit](#), provide a link to the license, and [indicate if changes were made](#). You may do so in any reasonable manner, but not in any way that suggests the licensor endorses you or your use.



**NonCommercial** — You may not use the material for [commercial purposes](#).



**ShareAlike** — If you remix, transform, or build upon the material, you must distribute your contributions under the [same license](#) as the original.

**No additional restrictions** — You may not apply legal terms or [technological measures](#) that legally restrict others from doing anything the license permits.

---

## Notices:

You do not have to comply with the license for elements of the material in the public domain or where your use is permitted by an applicable [exception or limitation](#).

No warranties are given. The license may not give you all of the permissions necessary for your intended use. For example, other rights such as [publicity, privacy, or moral rights](#) may limit how you use the material.

1

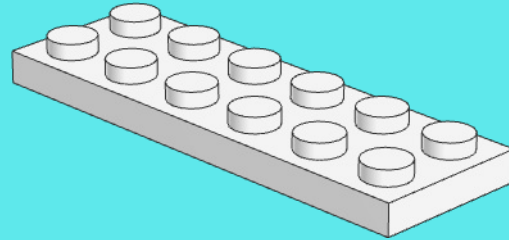
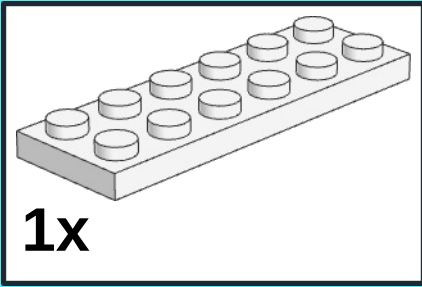

2

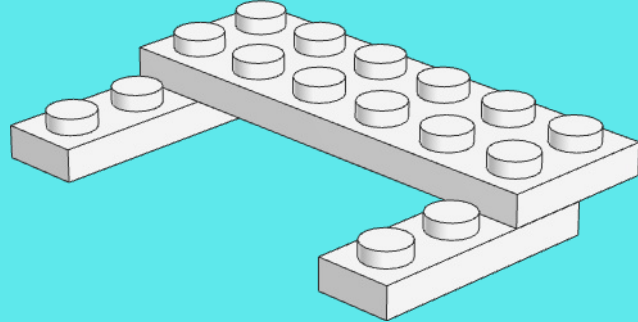
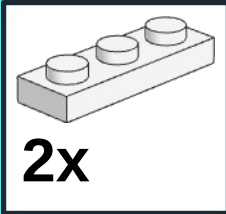

3

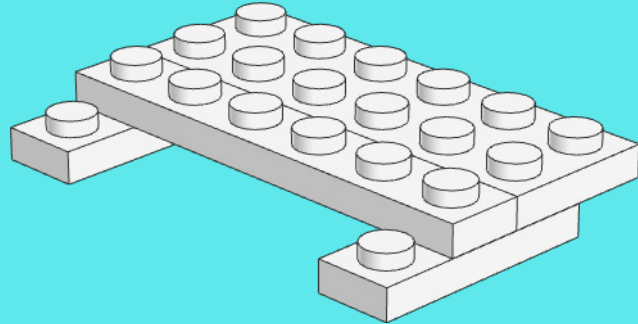
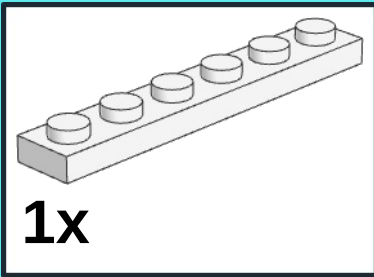

4

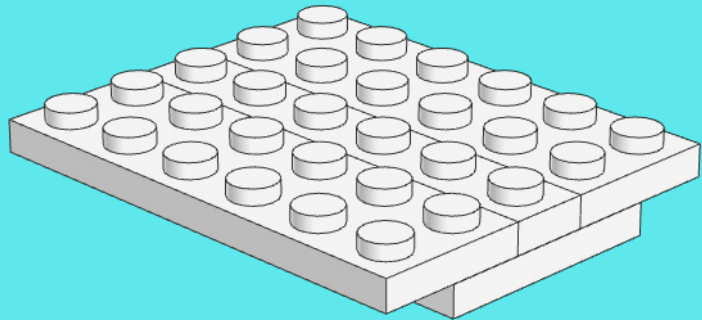
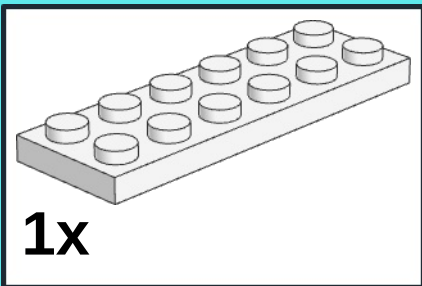

5

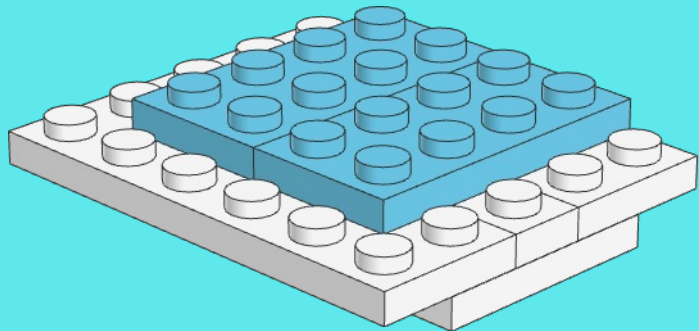
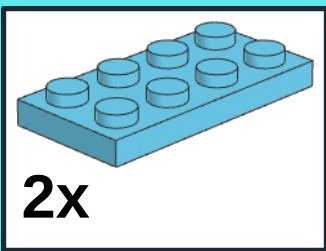

6

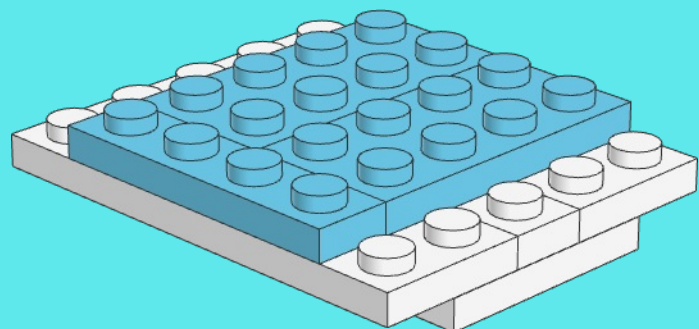
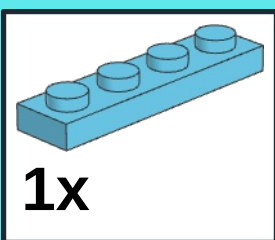

7

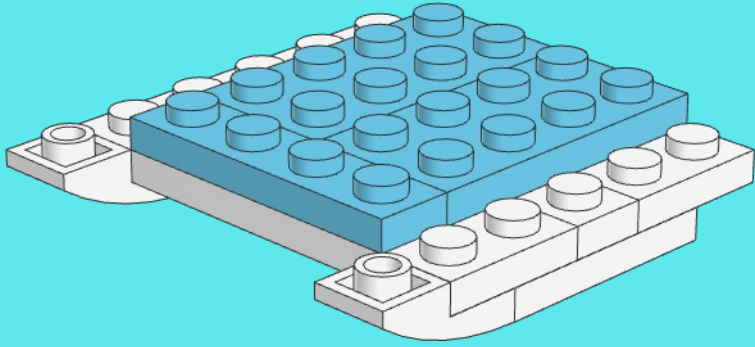
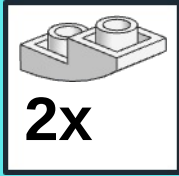

8

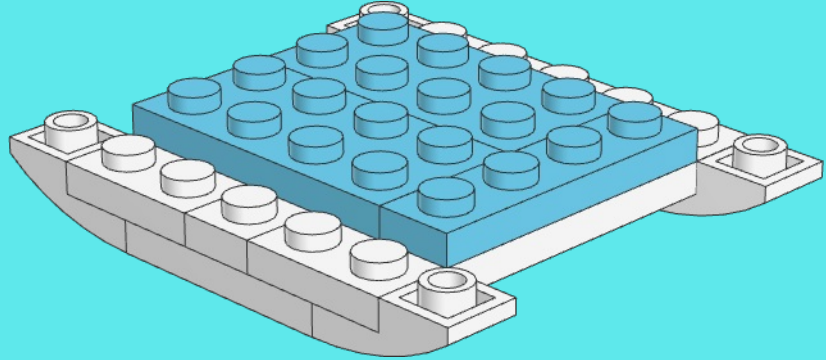
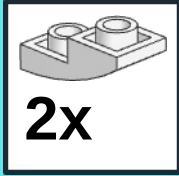

9

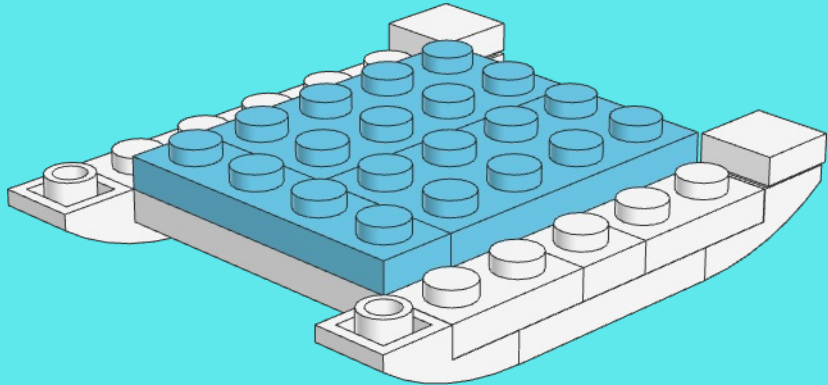

10

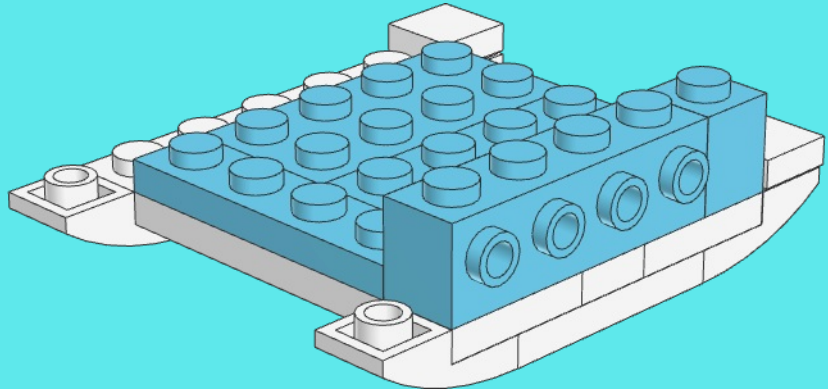
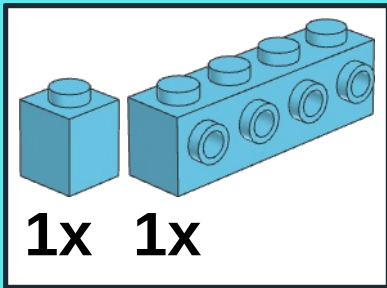

11

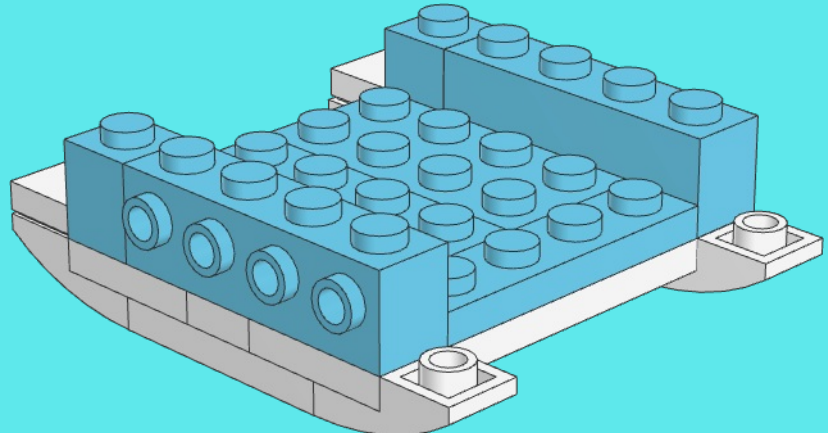
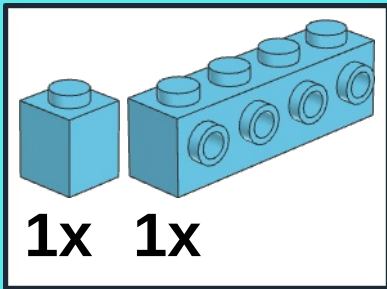

12

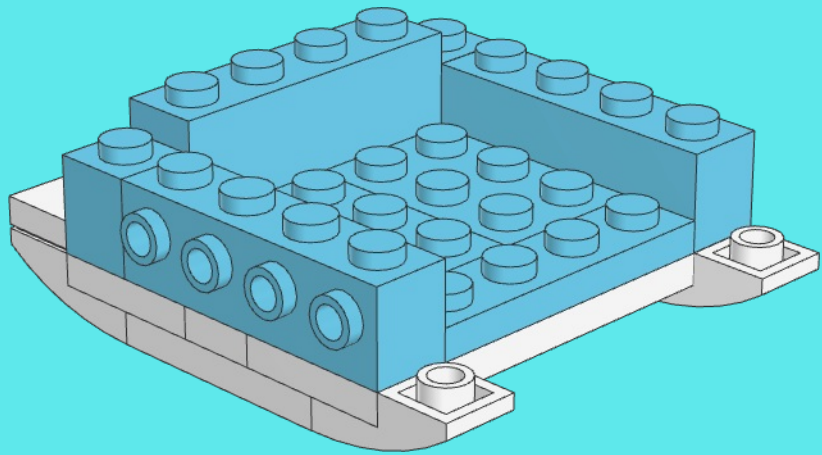
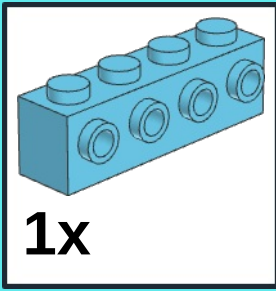

13

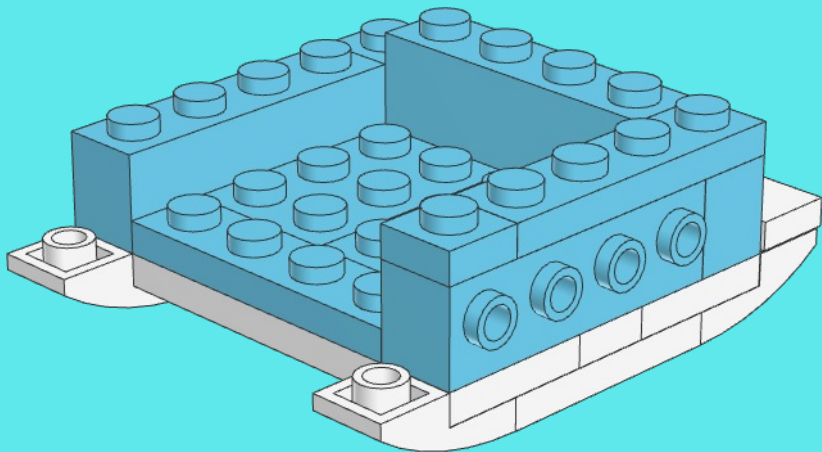
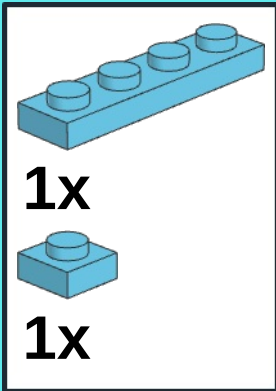

14

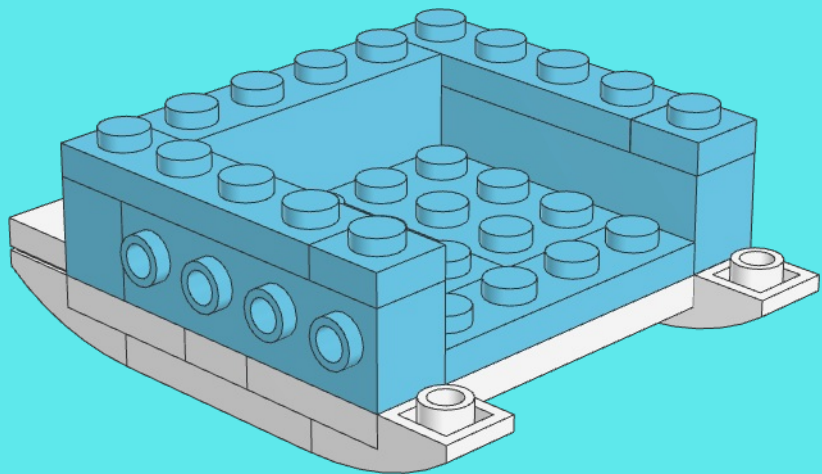
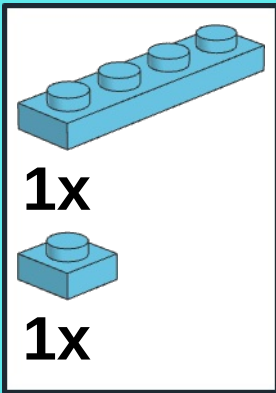

15

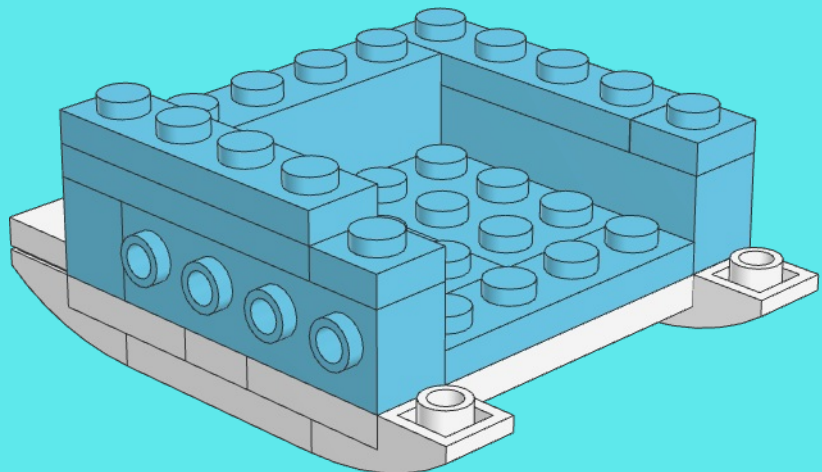
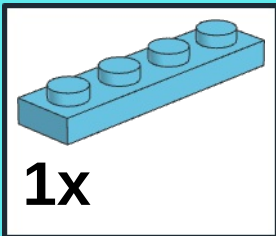

16

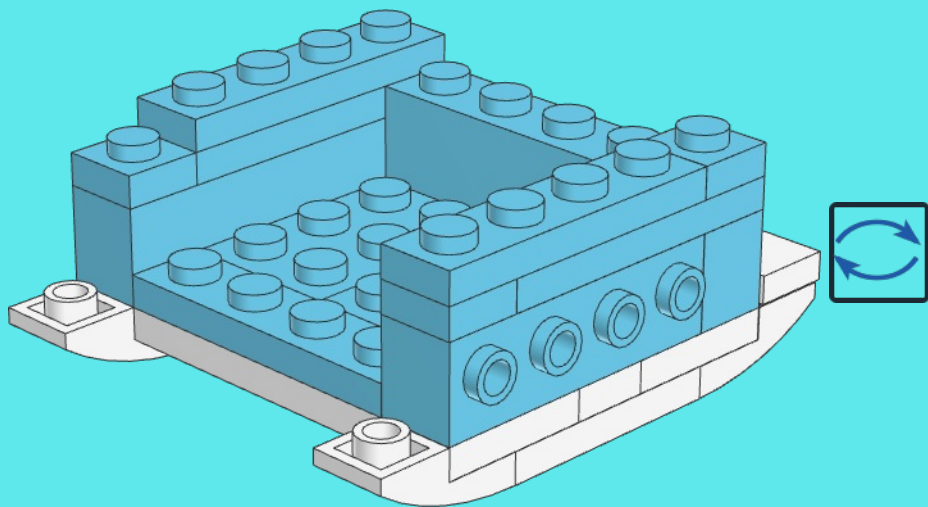
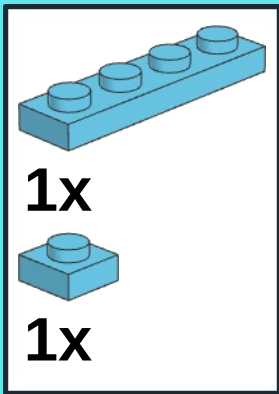

17

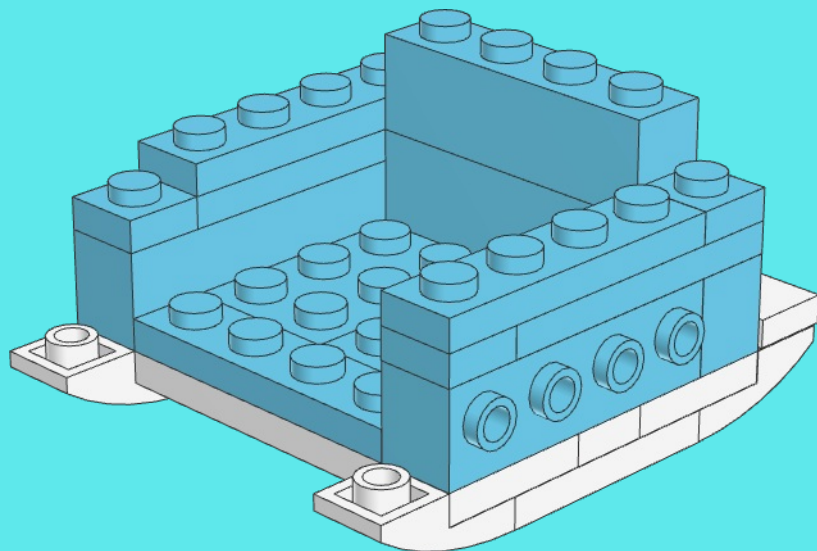
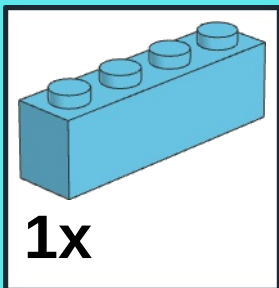

18

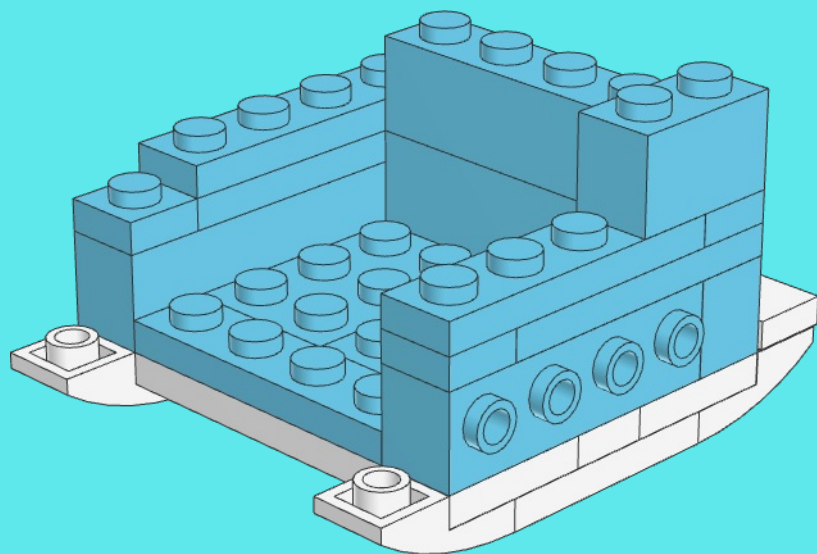
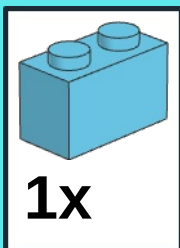

19

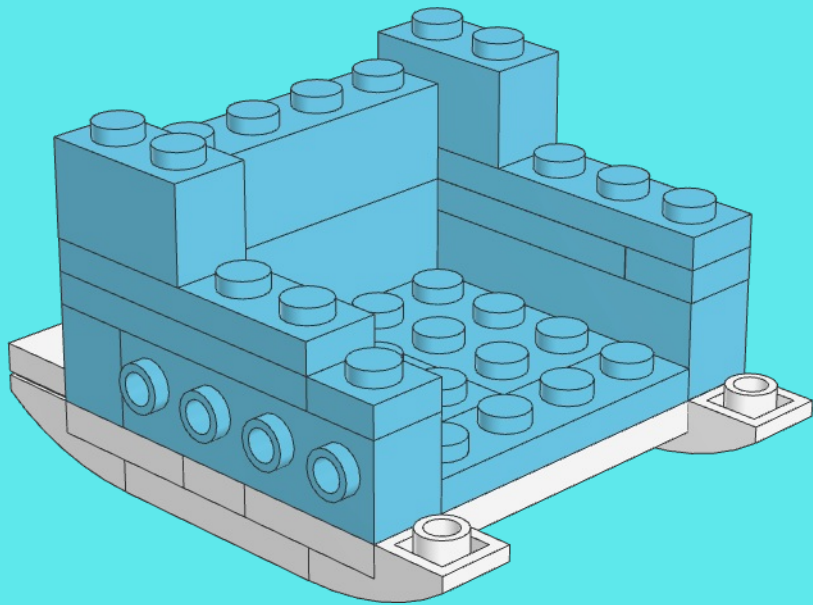
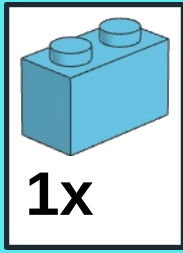

20

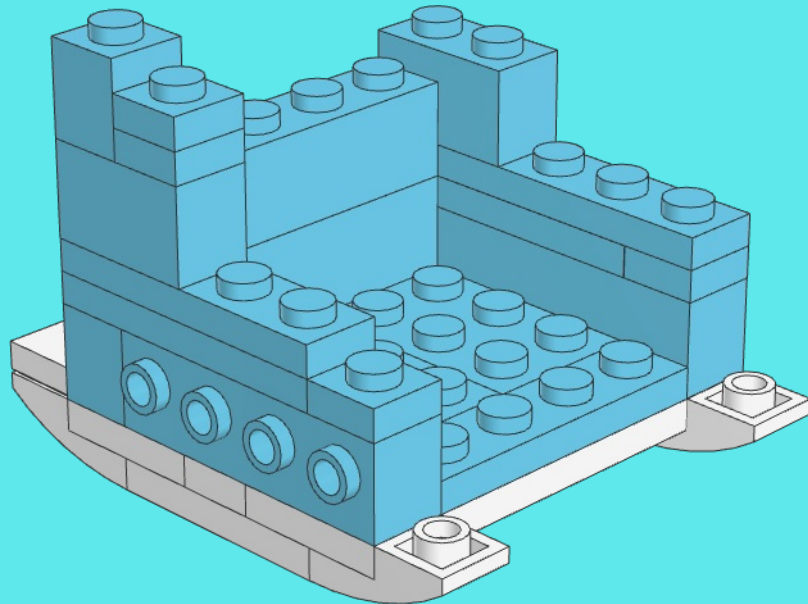

21

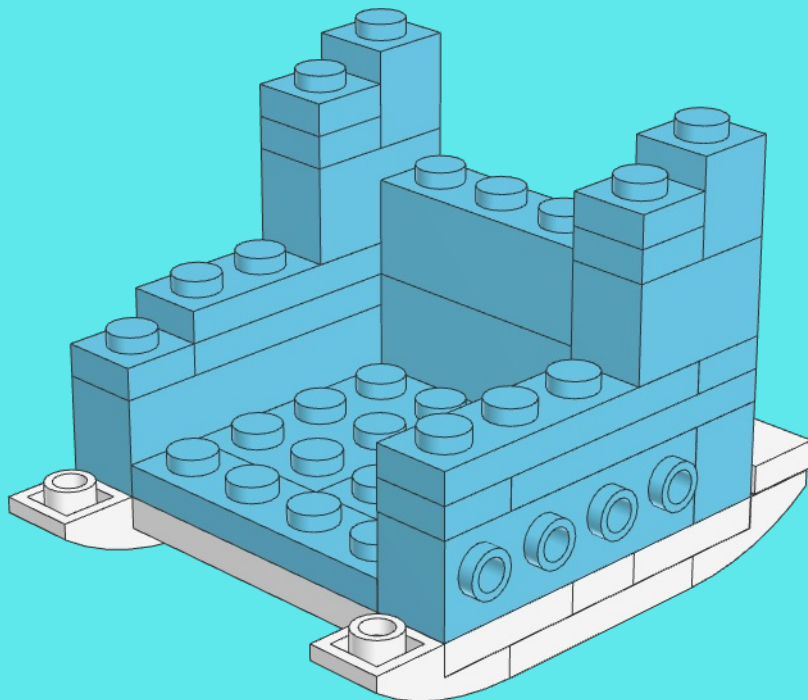



22

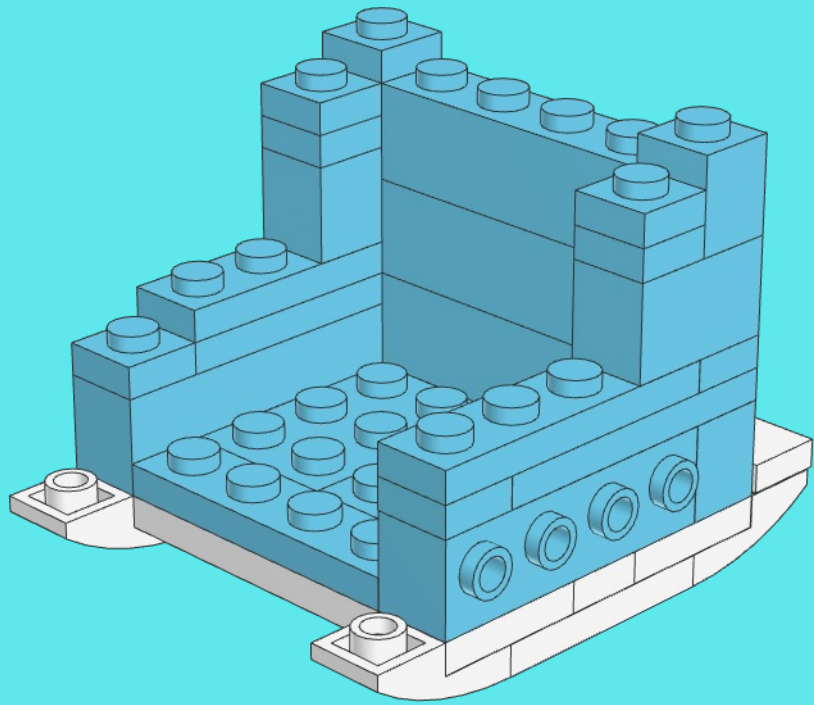
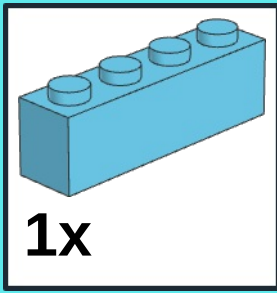

23

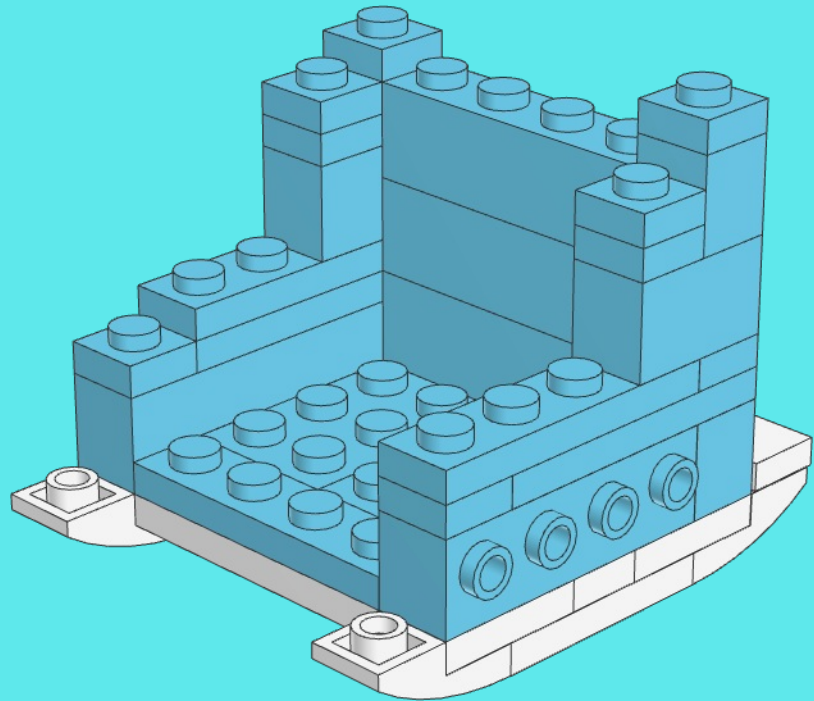
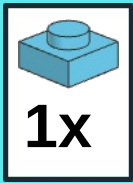

24

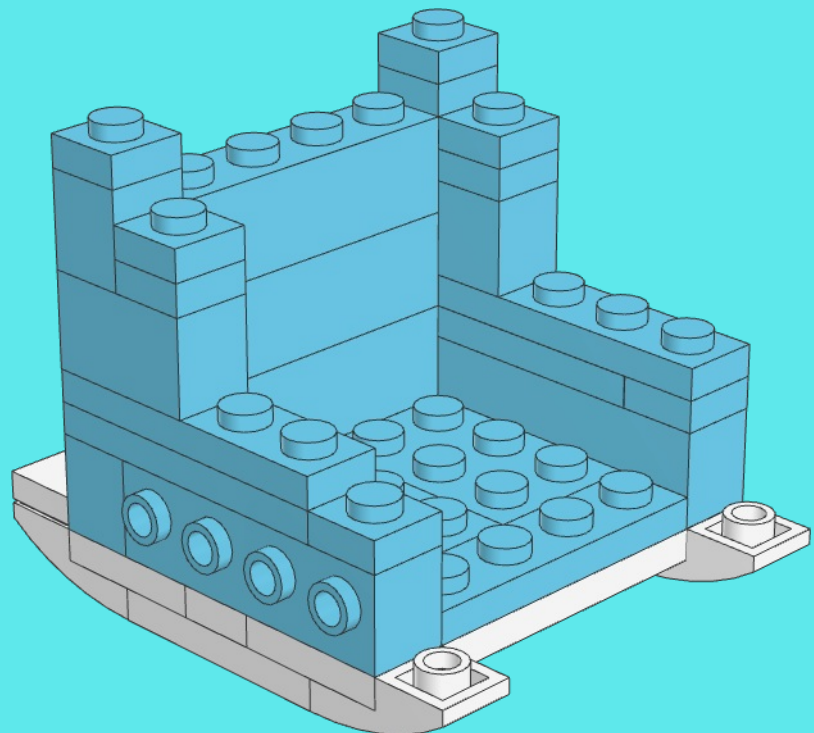
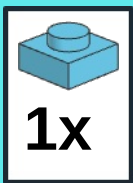

25

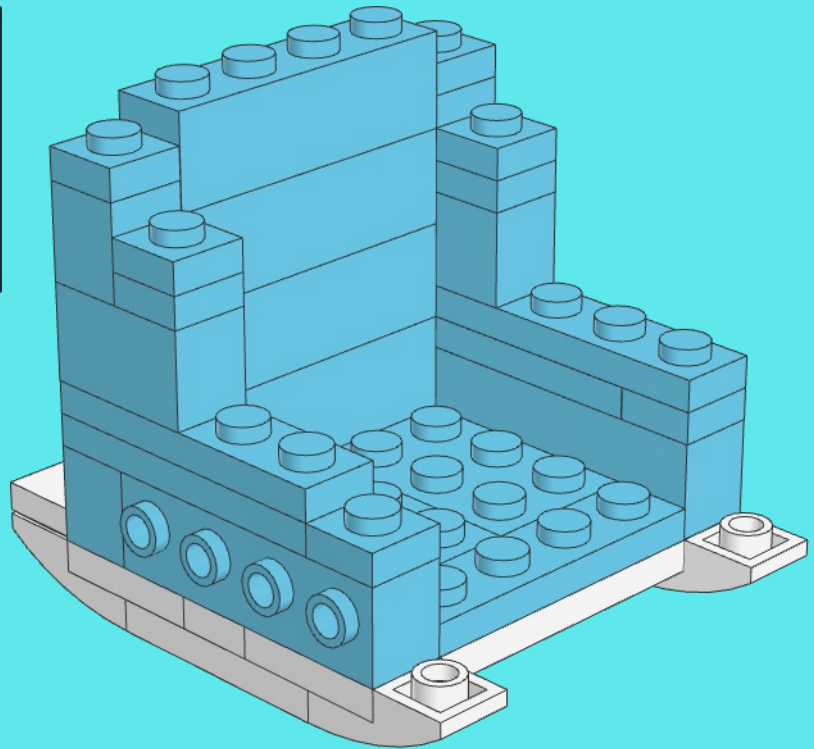
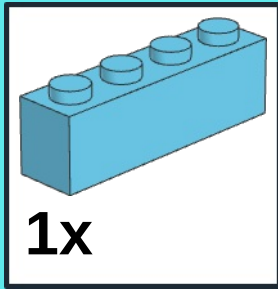

26

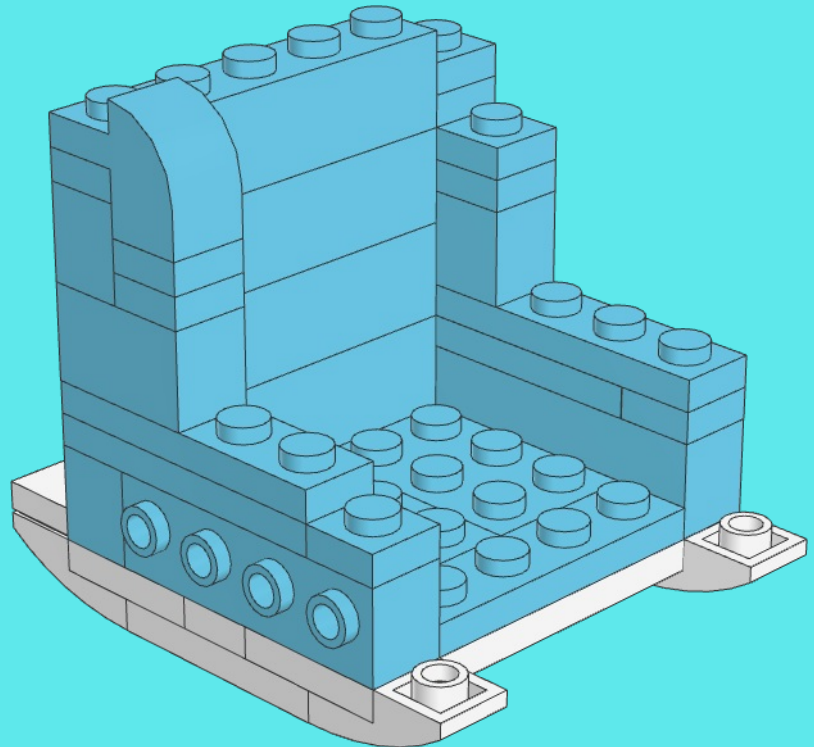
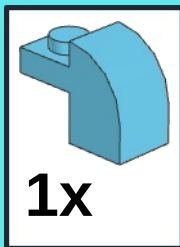

27

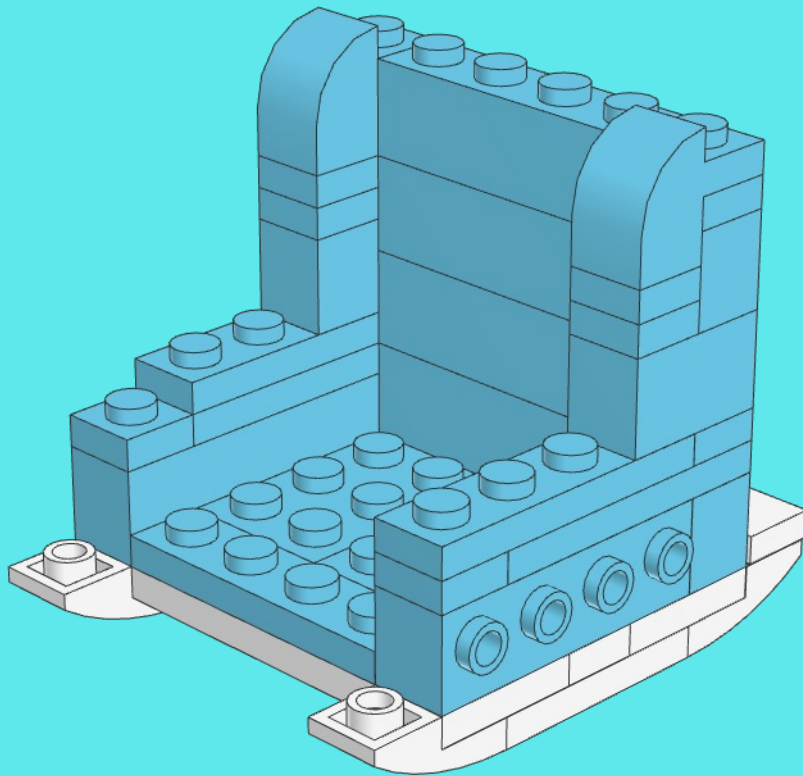
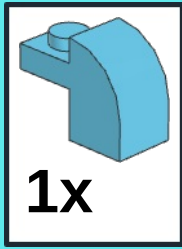

28

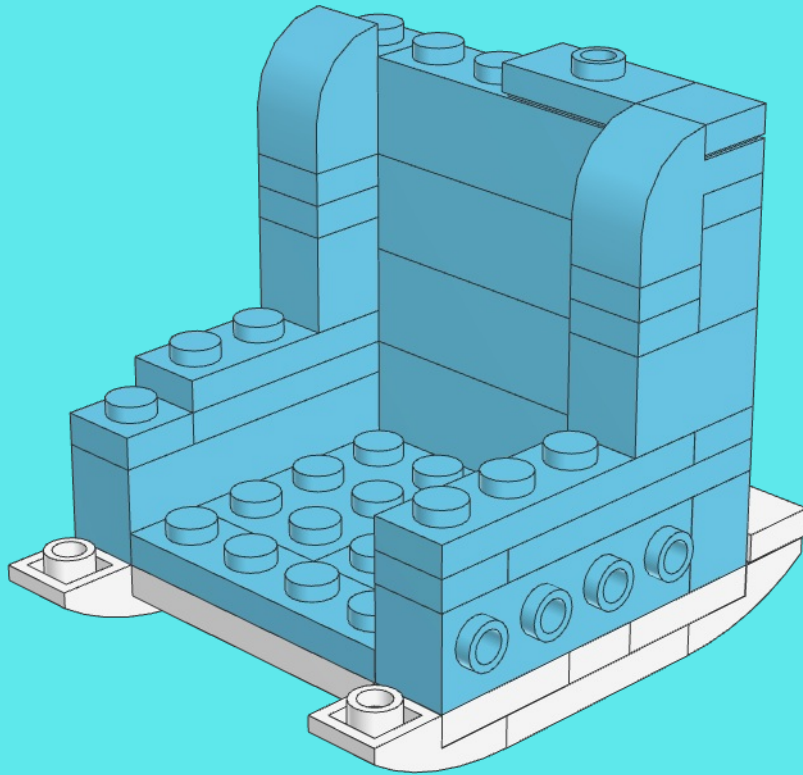
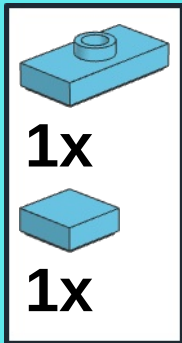

29

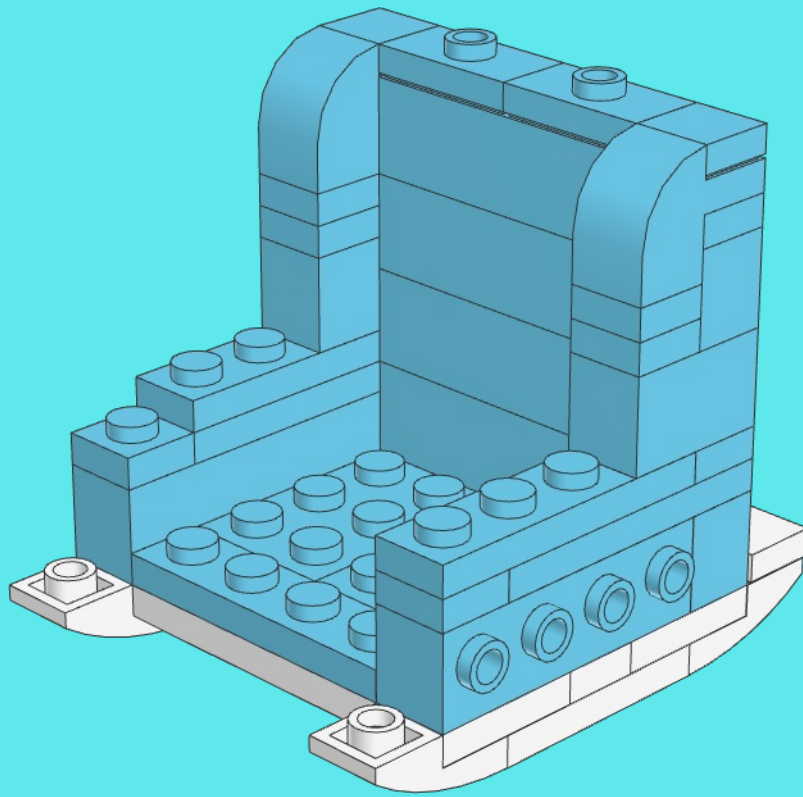
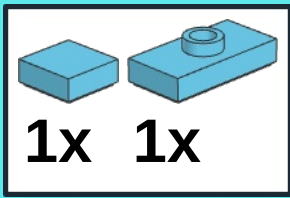

1

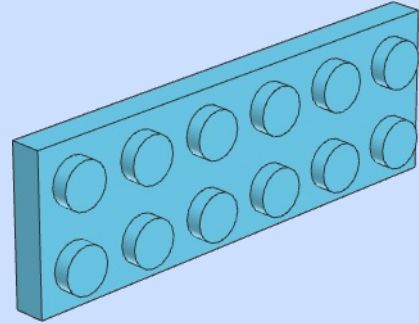
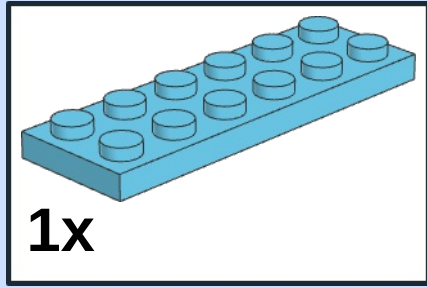

2

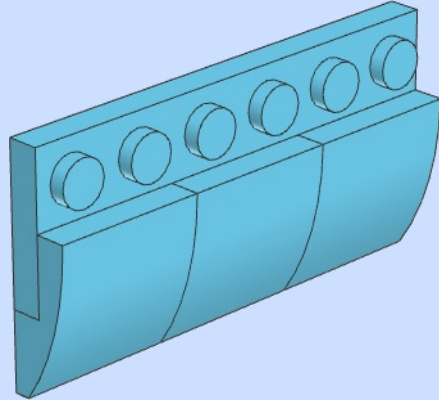
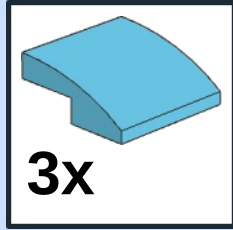

3

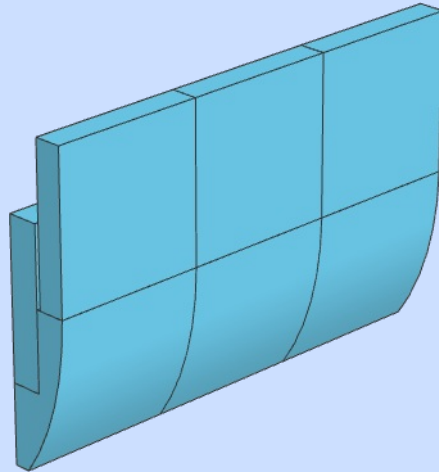
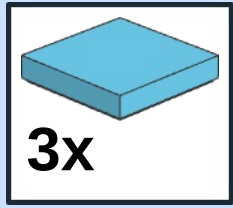

4

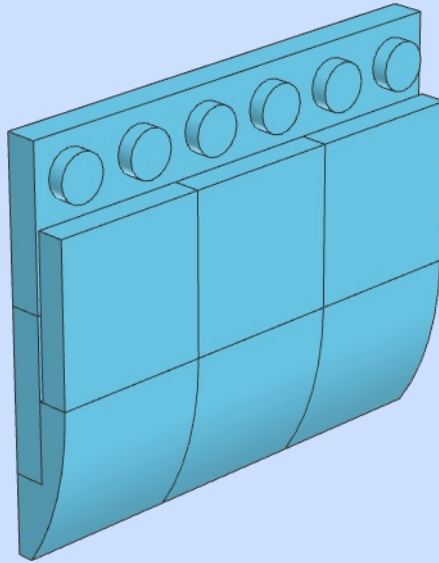
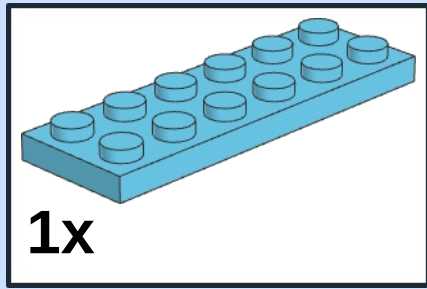

5

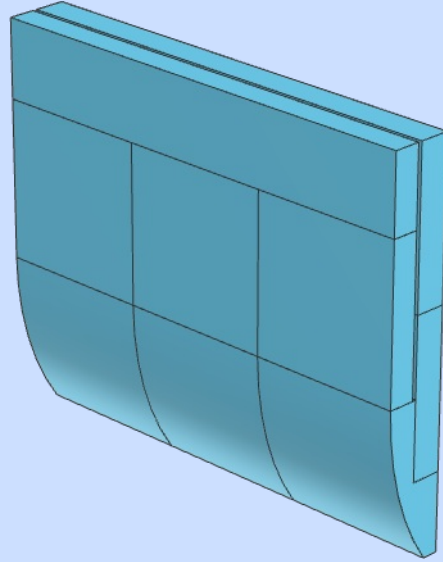
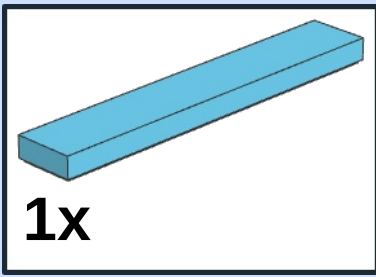

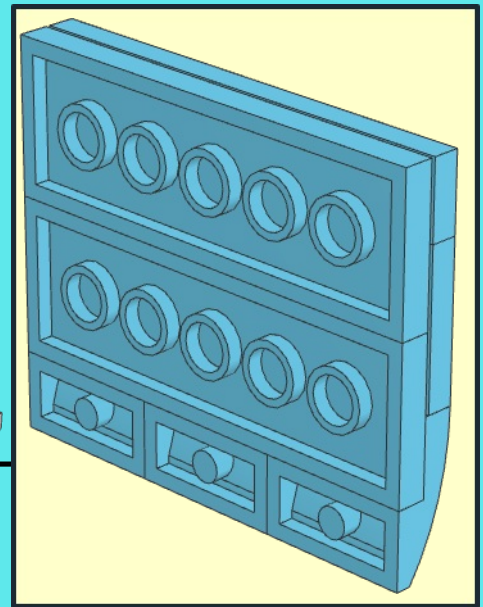
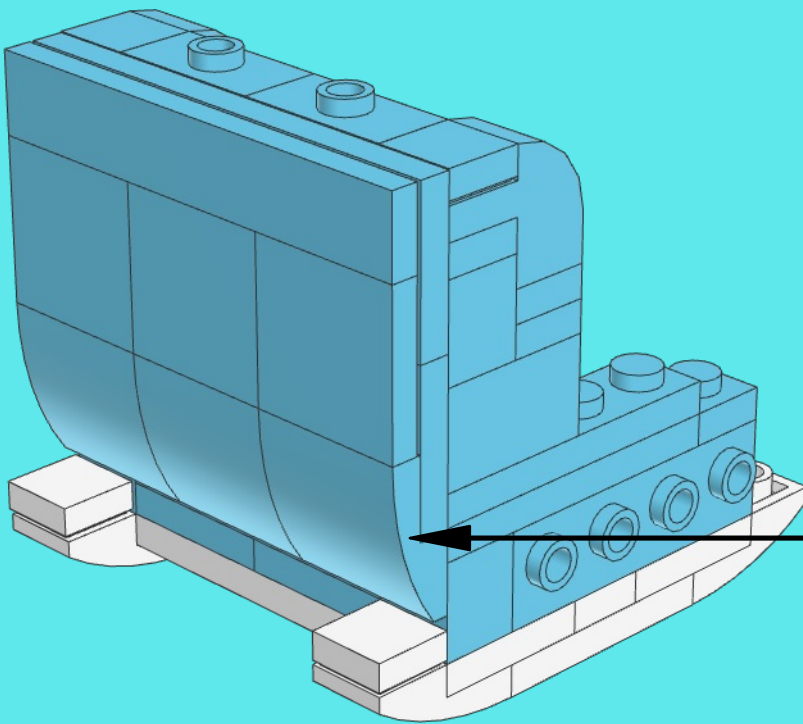

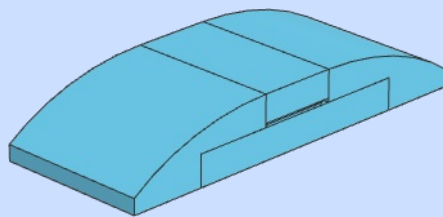
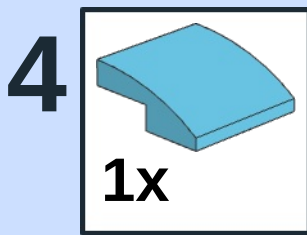
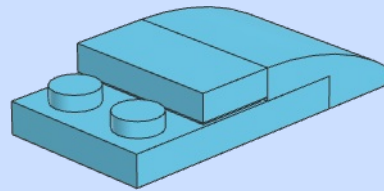
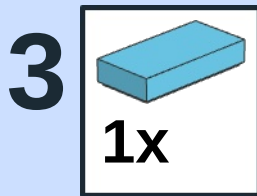
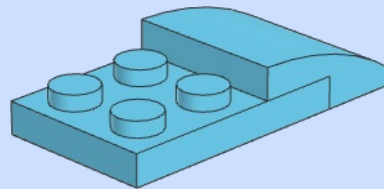
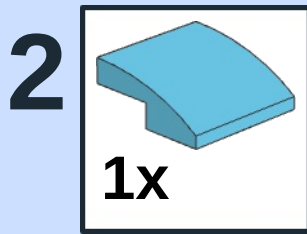
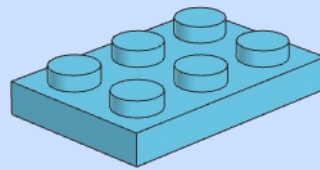
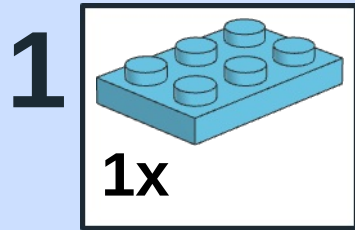



1

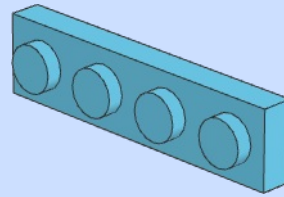
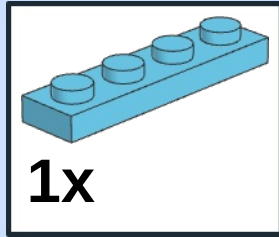

2

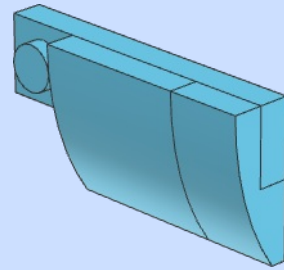
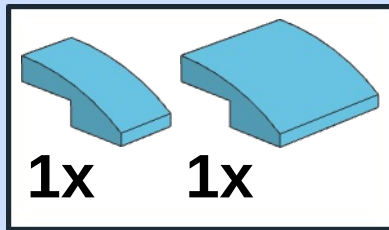

3

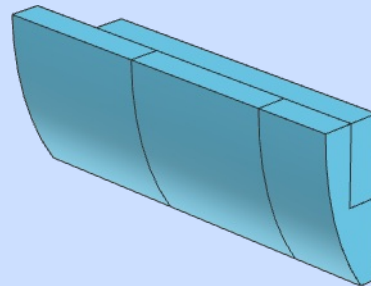
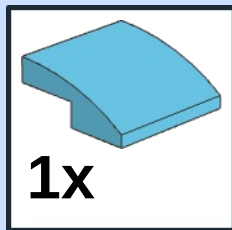

4

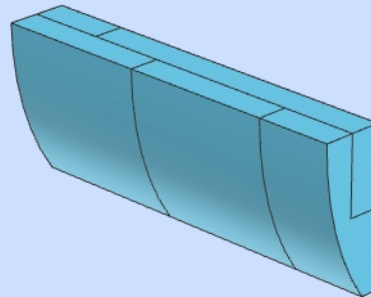
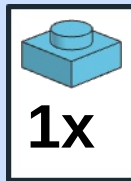

31

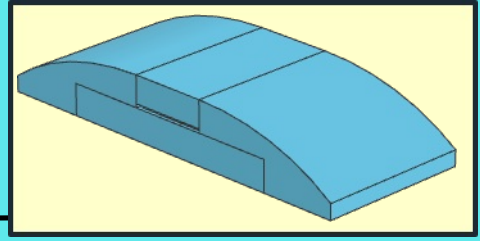
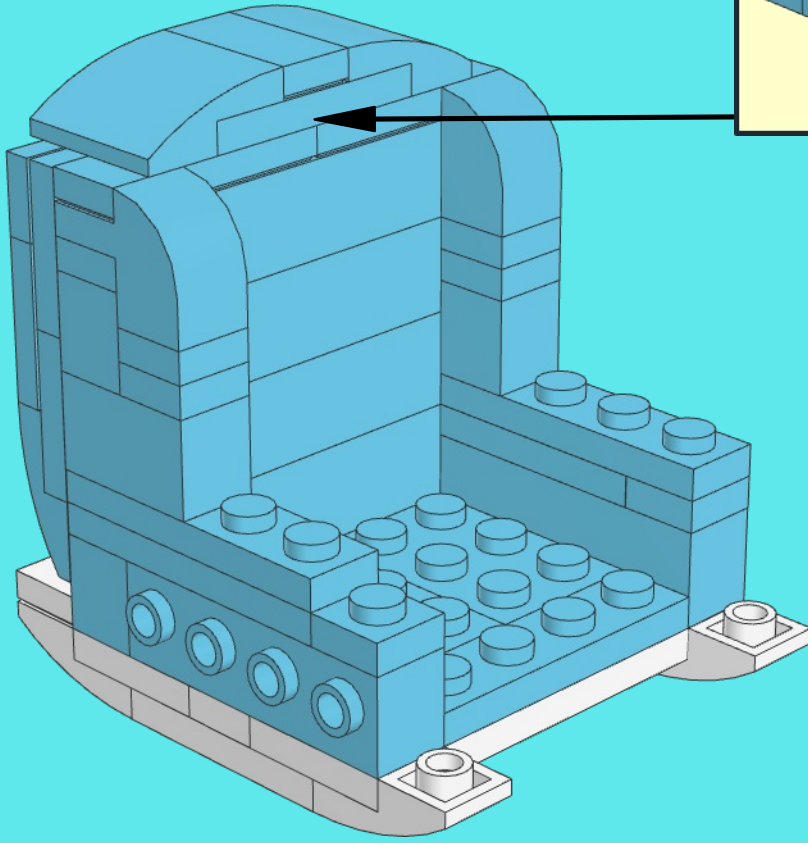

32

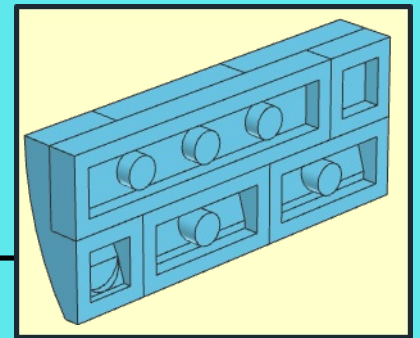
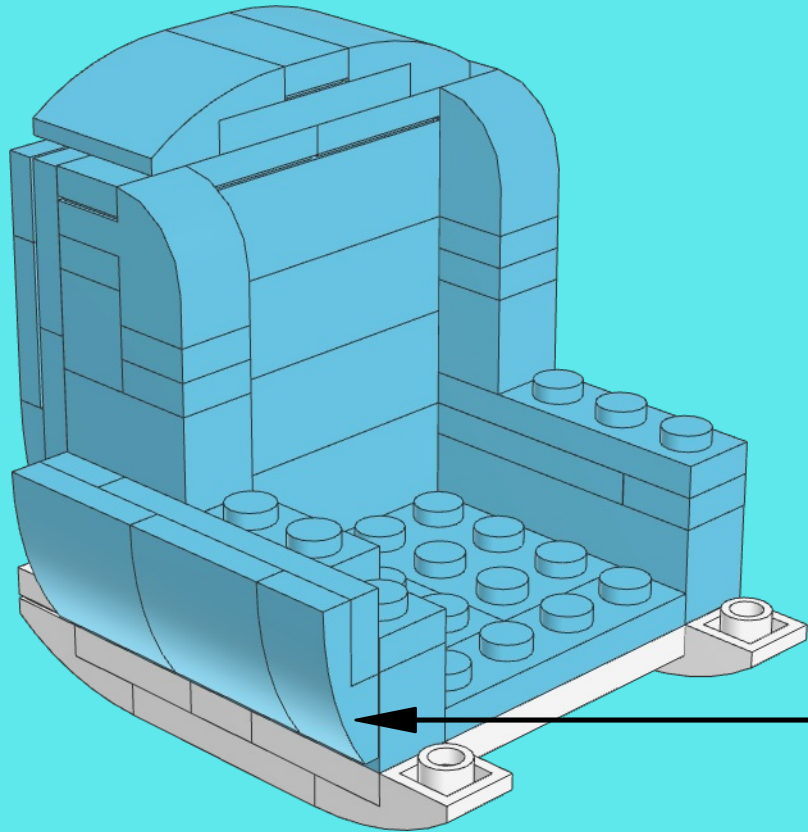

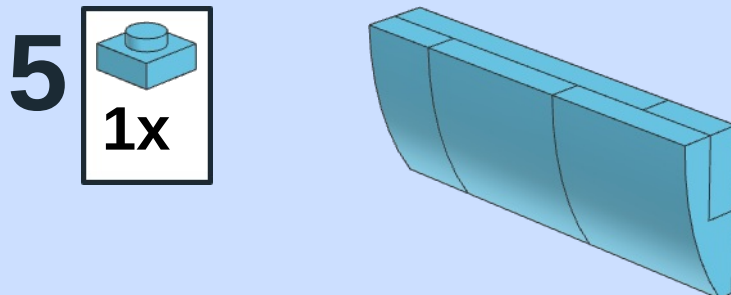
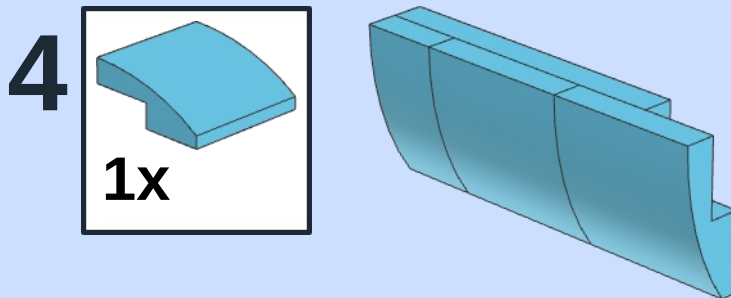
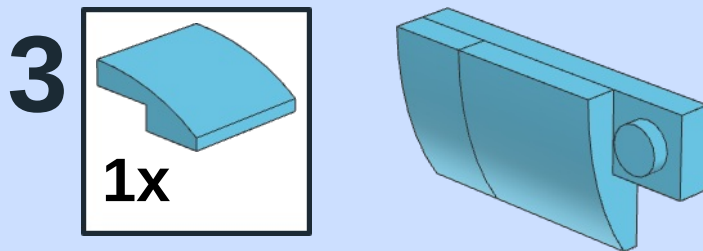
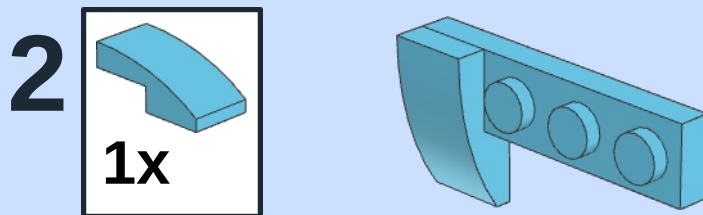
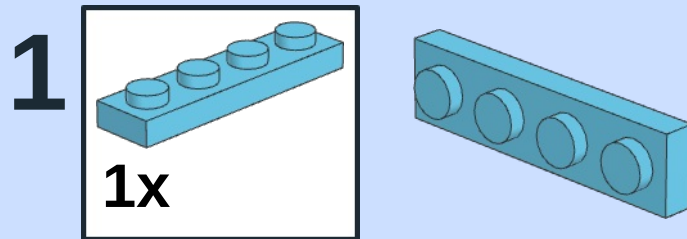

33

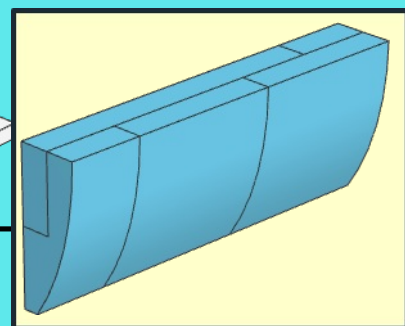
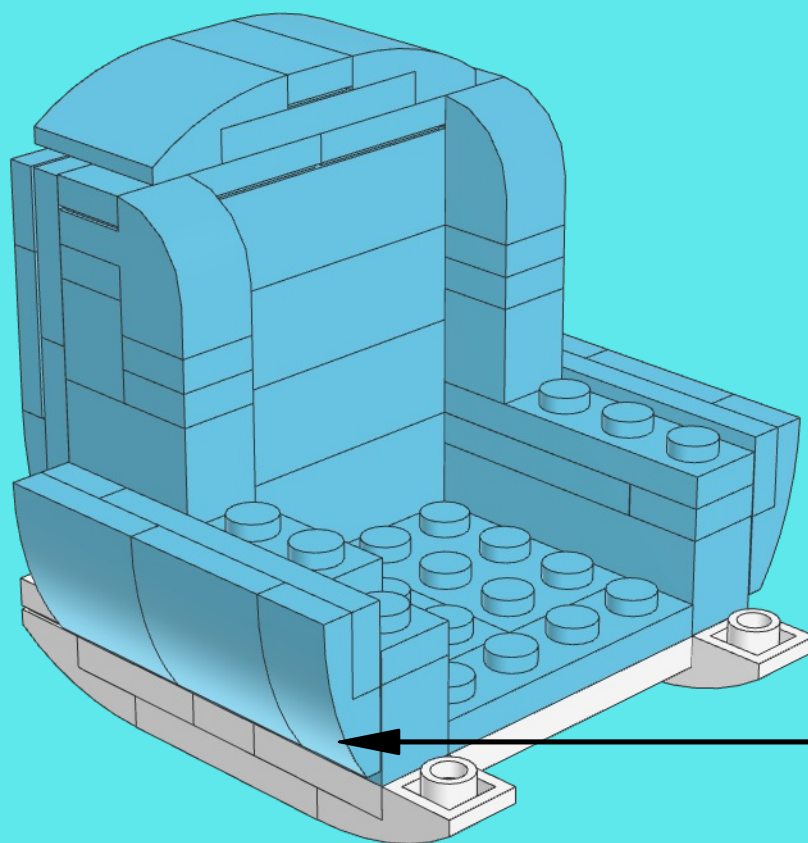

34

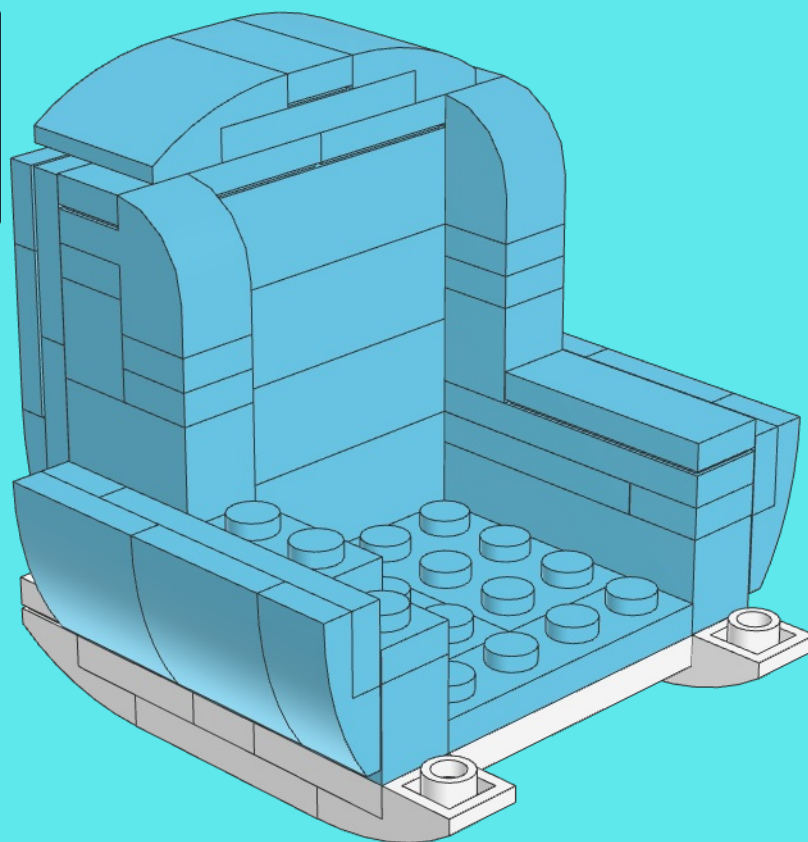
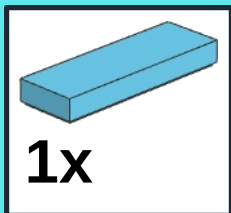

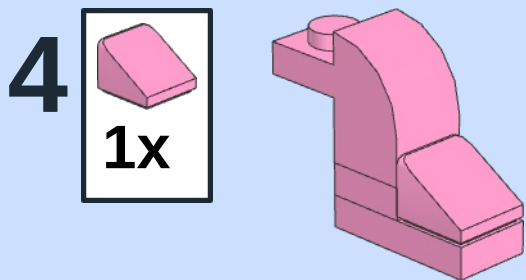
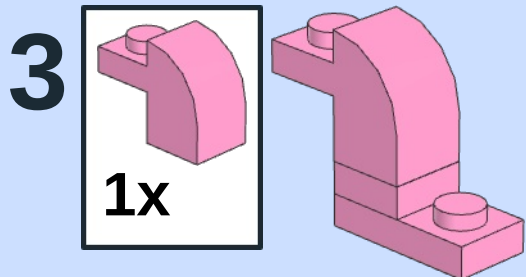
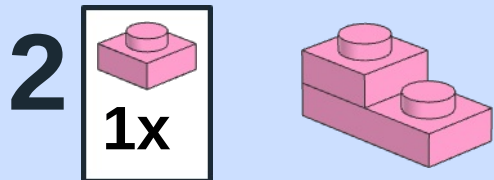
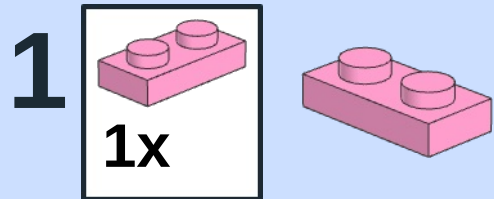

35

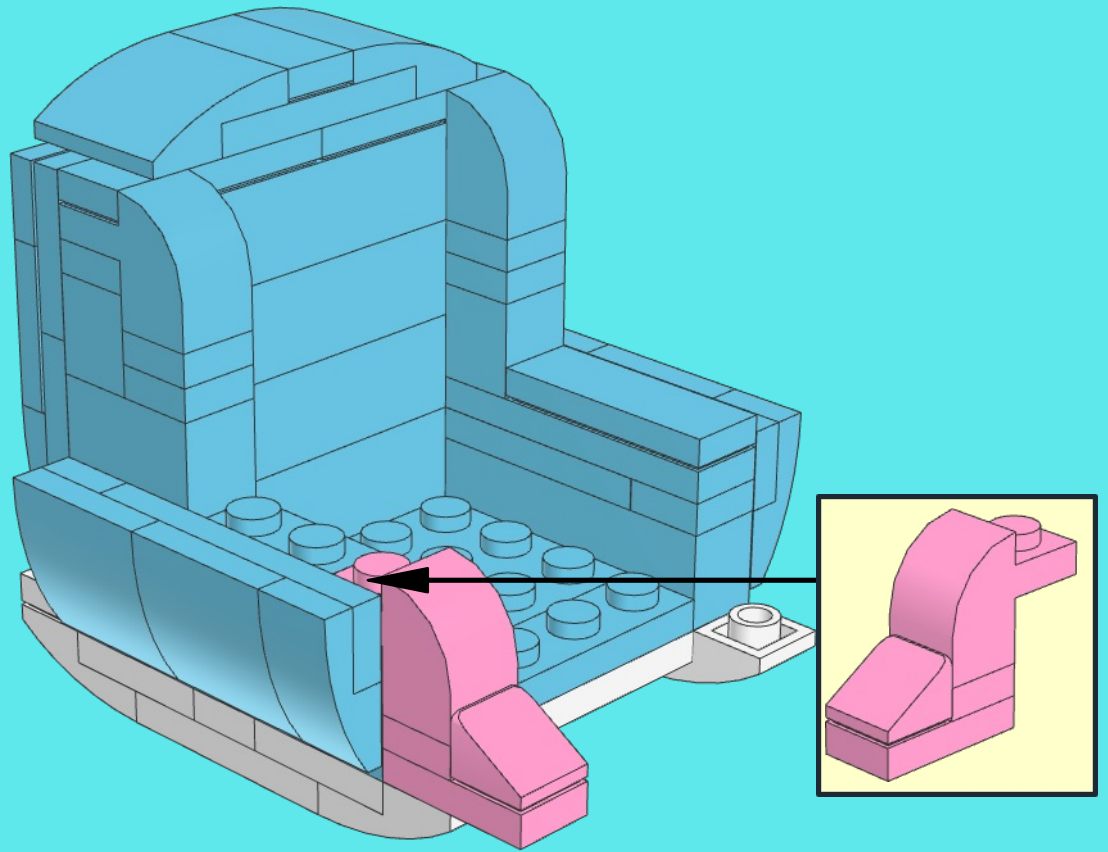

36

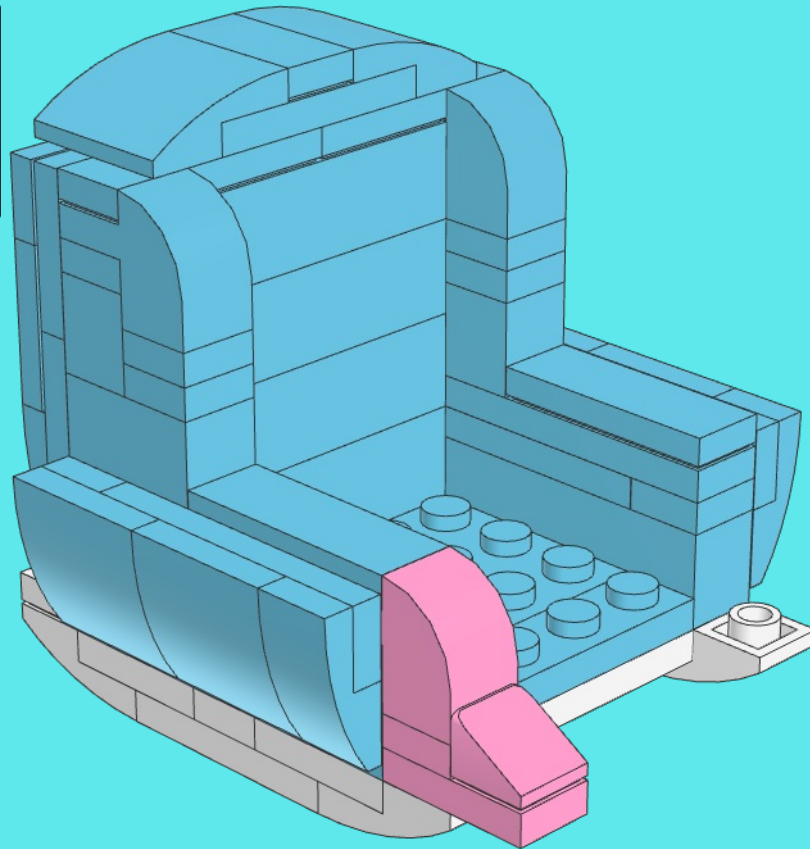
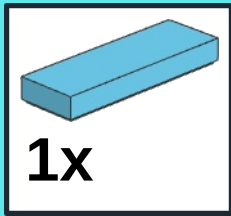

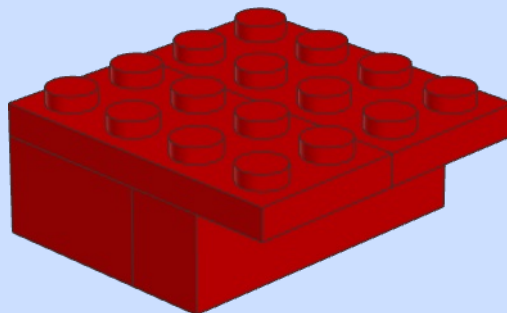
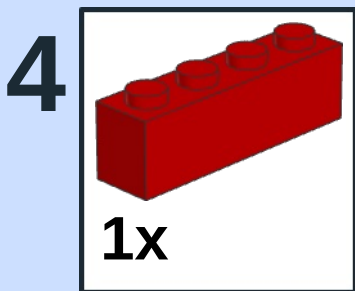
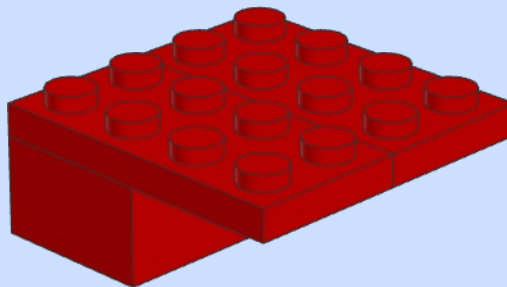
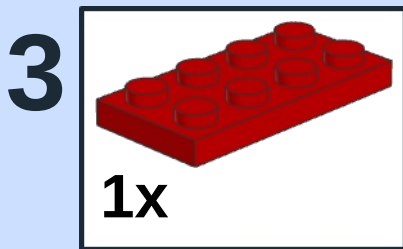
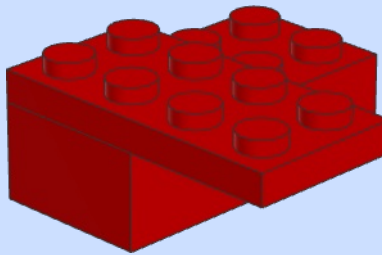
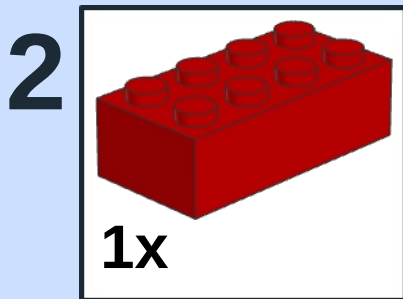
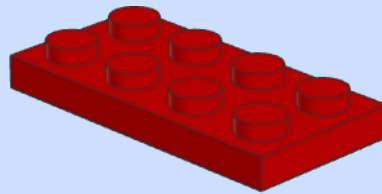
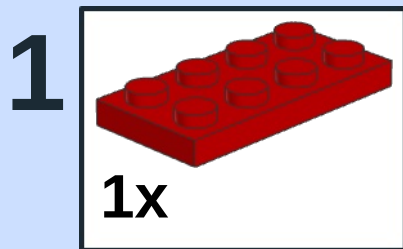

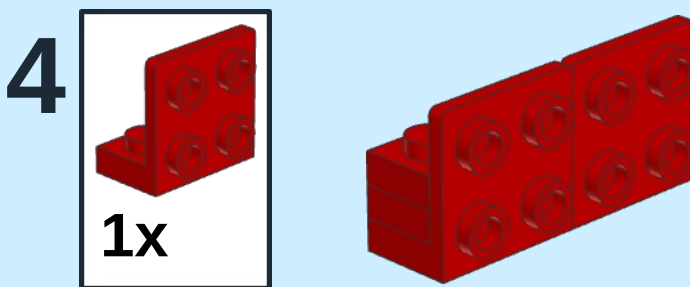
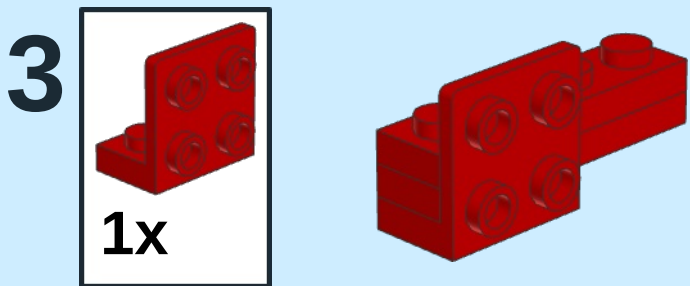
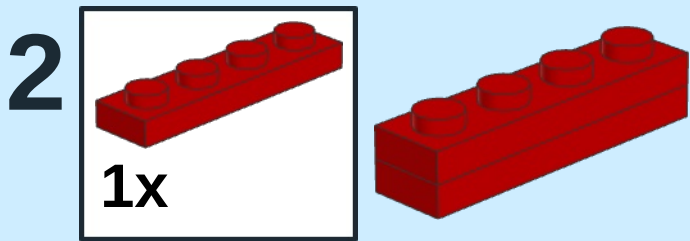
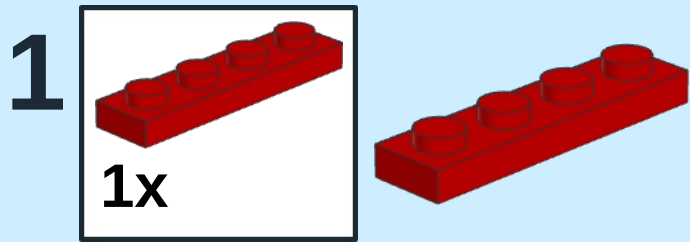



5

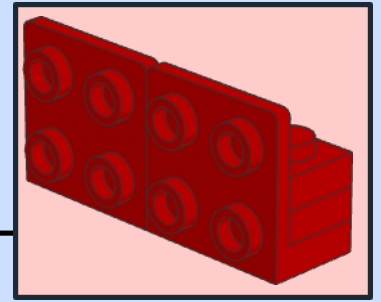
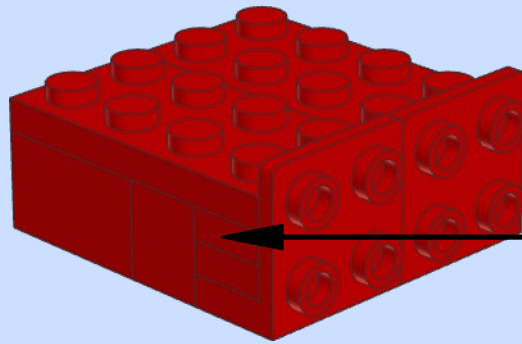

6

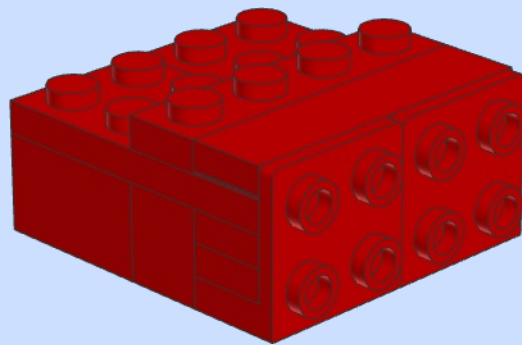
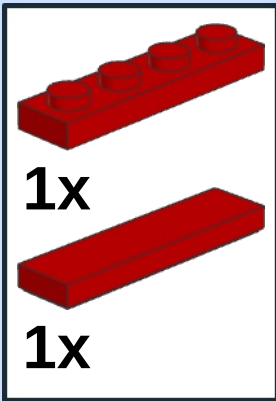

7

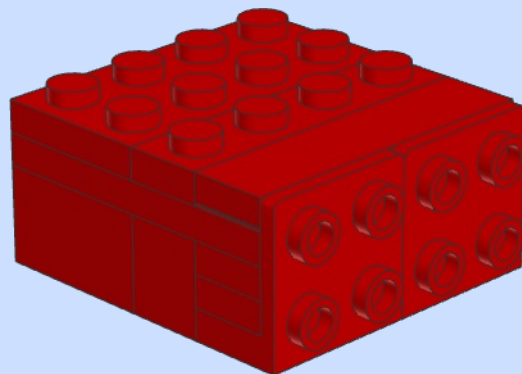
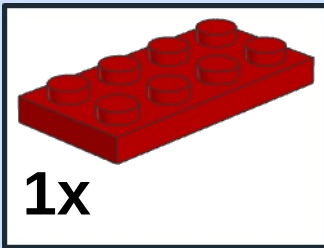

8

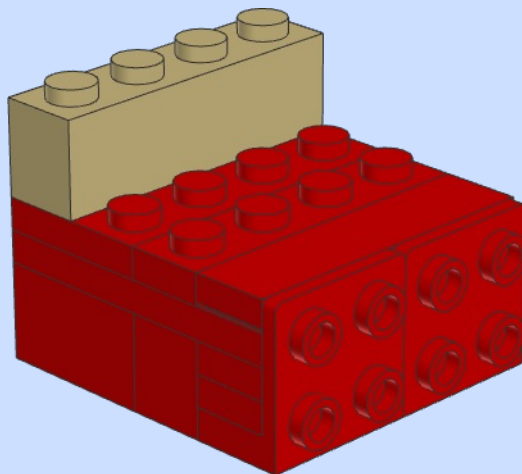
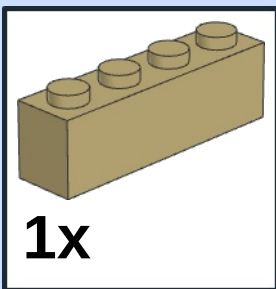

37

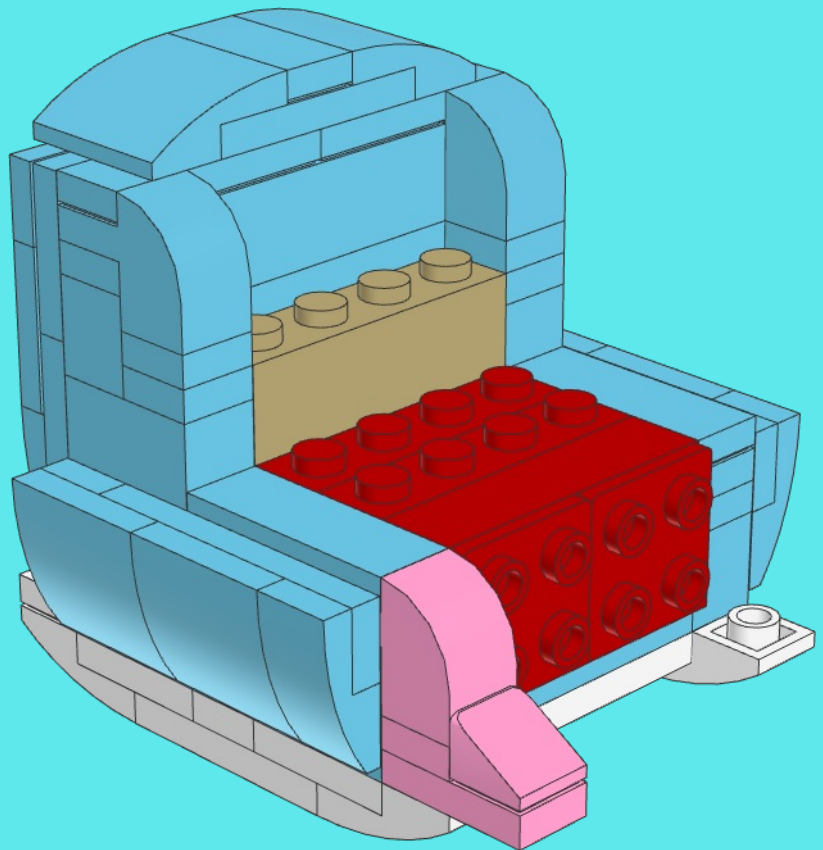

38

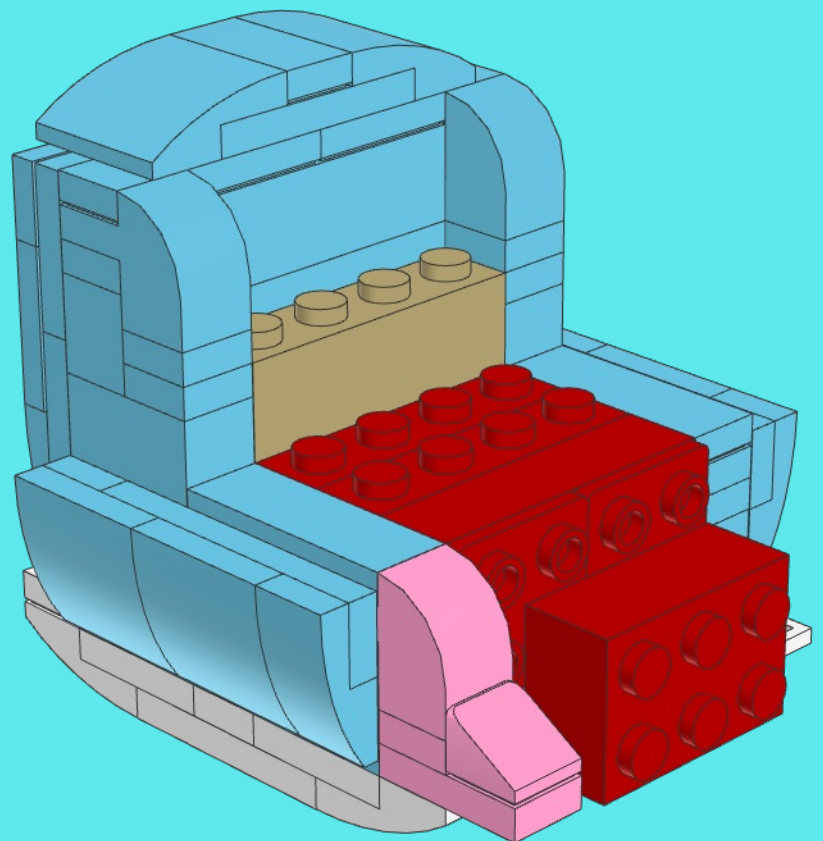
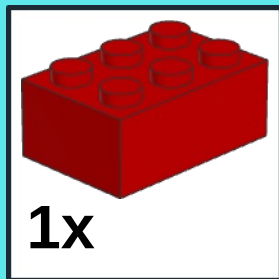

39

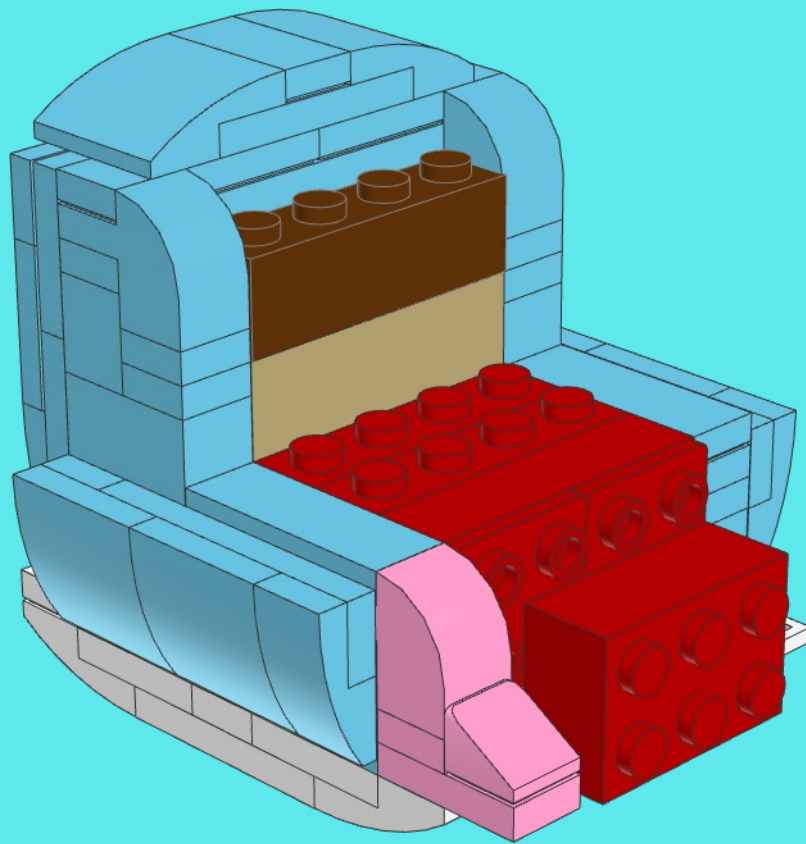
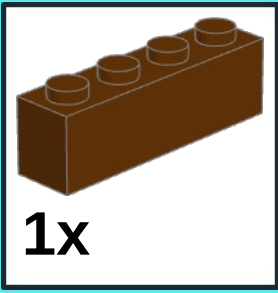

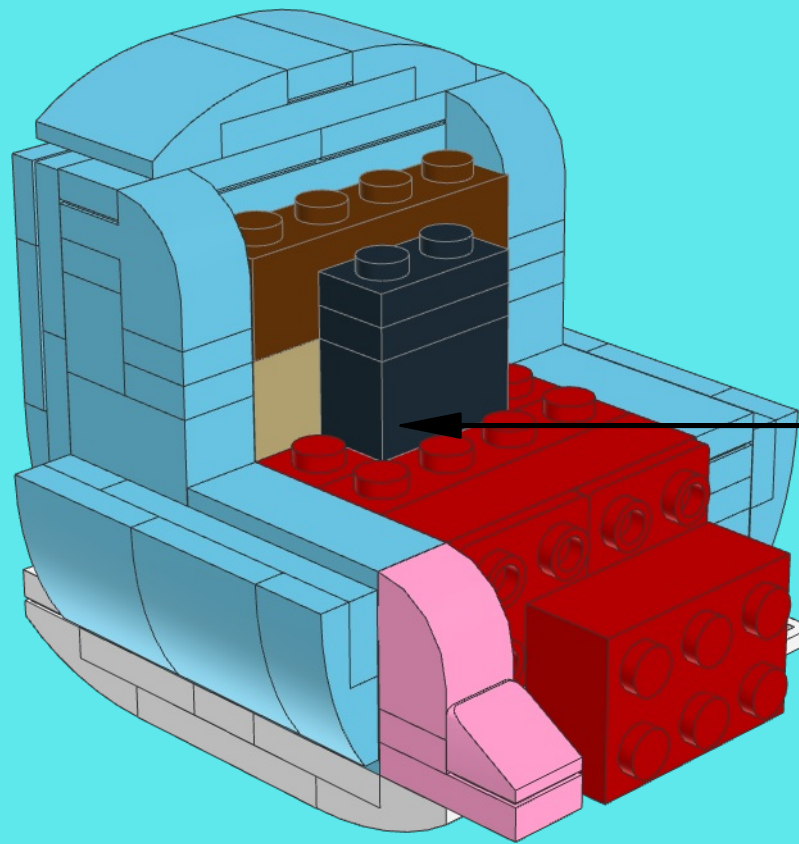

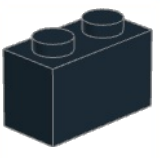
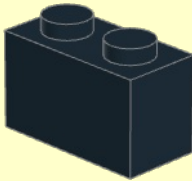
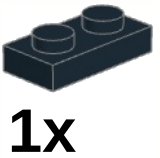
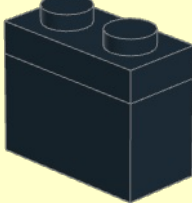
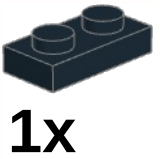
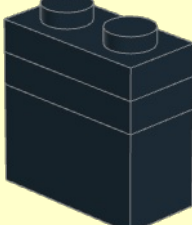
- 1**  
  
**1x**  

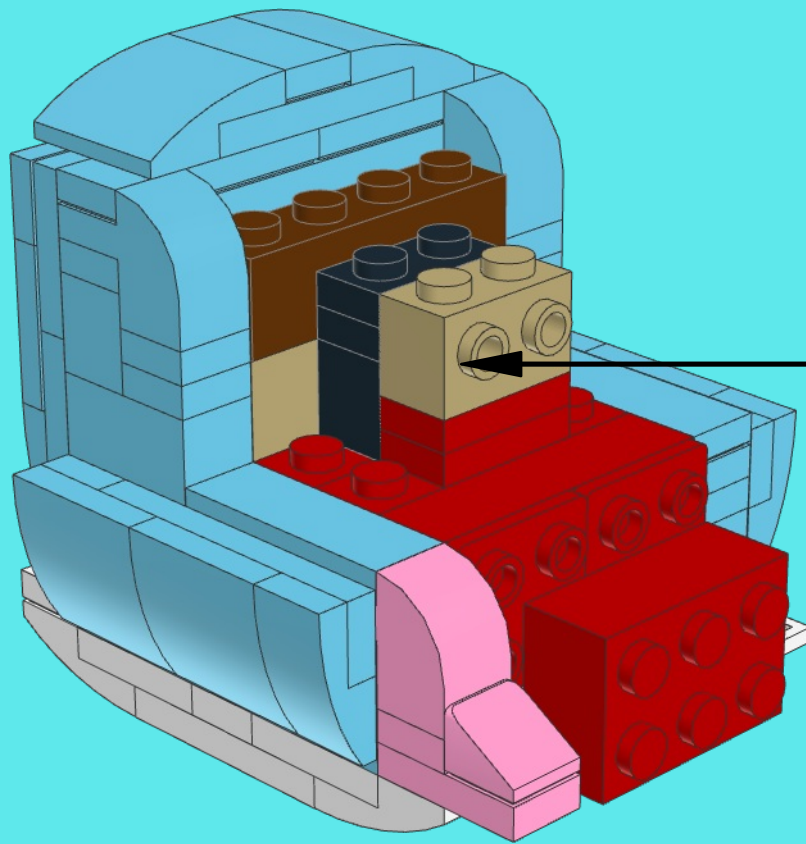
- 2**  
  
**1x**  

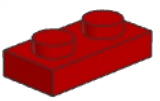
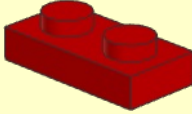
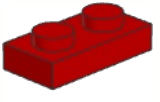
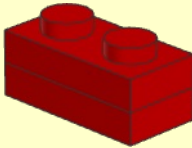
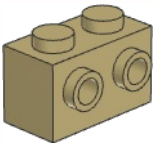
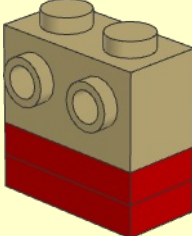
- 3**  
  
**1x**  

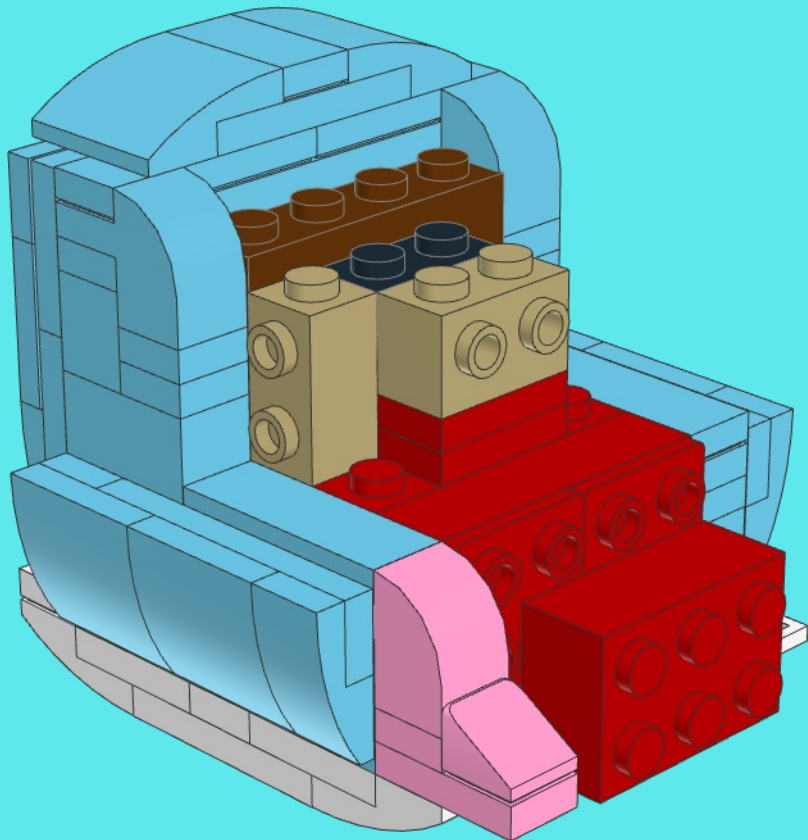
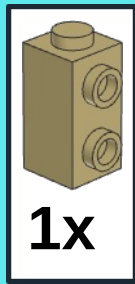

- 1**   
**1x**  

- 2**   
**1x**  

- 3**   
**1x**  

42

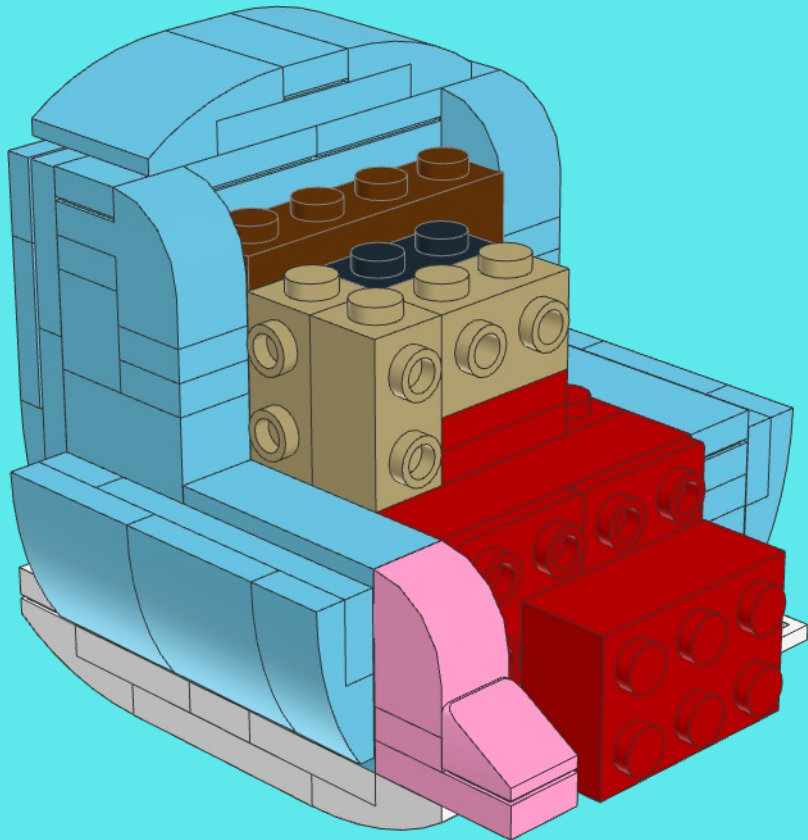
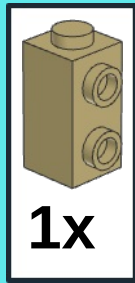

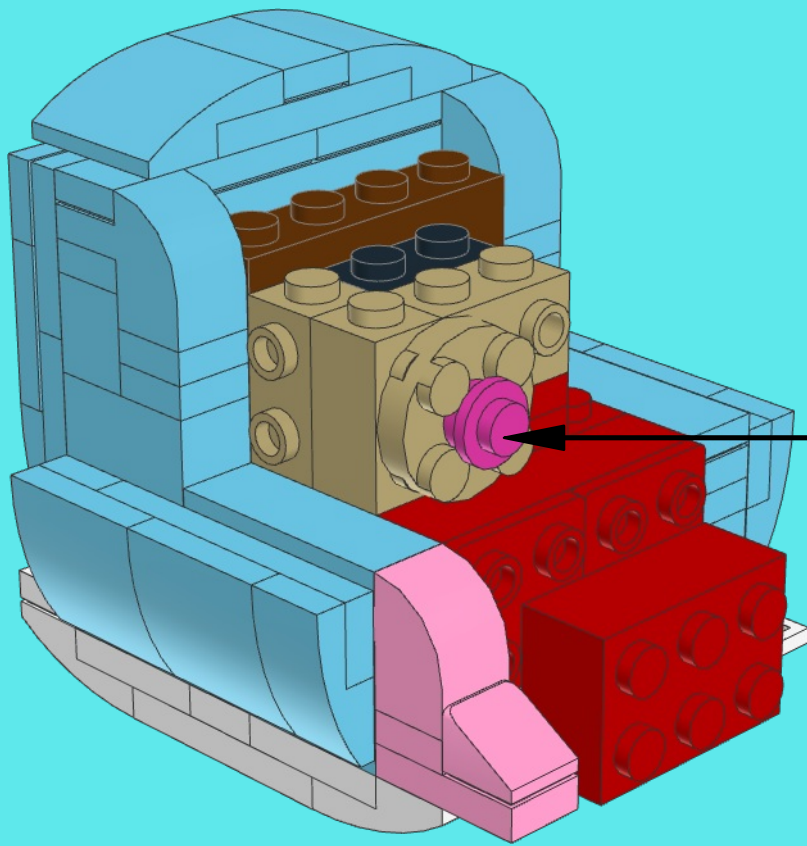
43





1

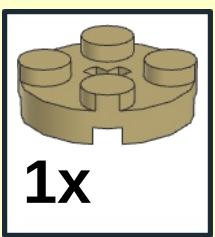

1x



2



1x



45

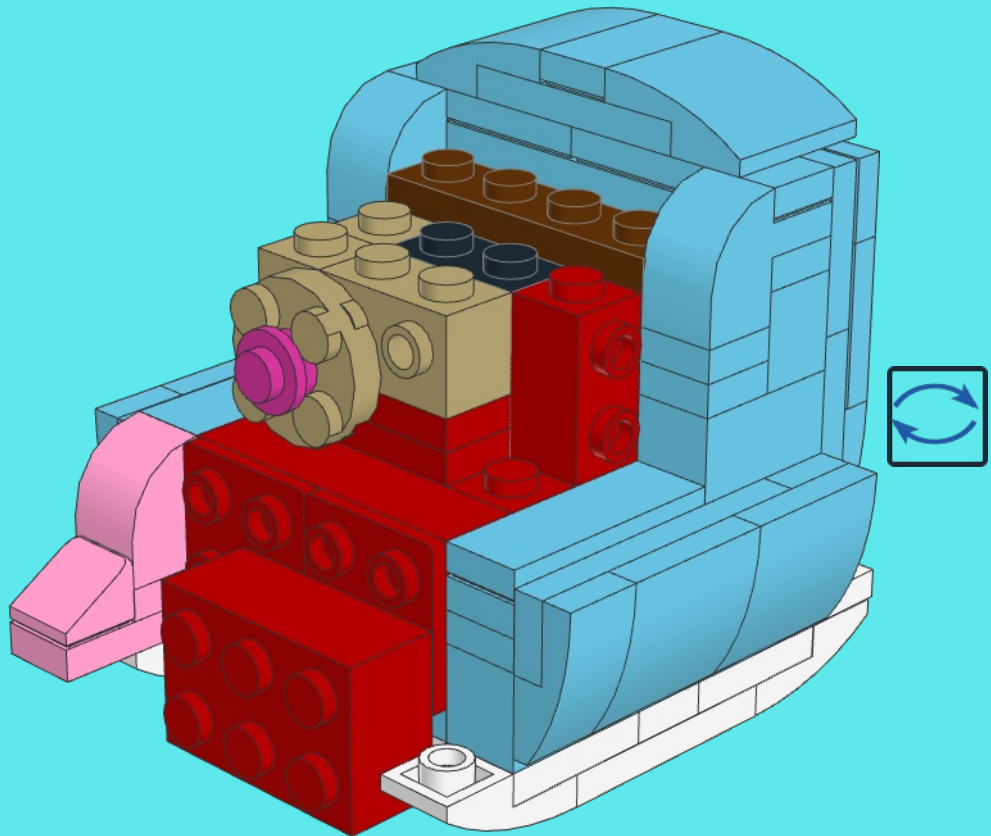

46

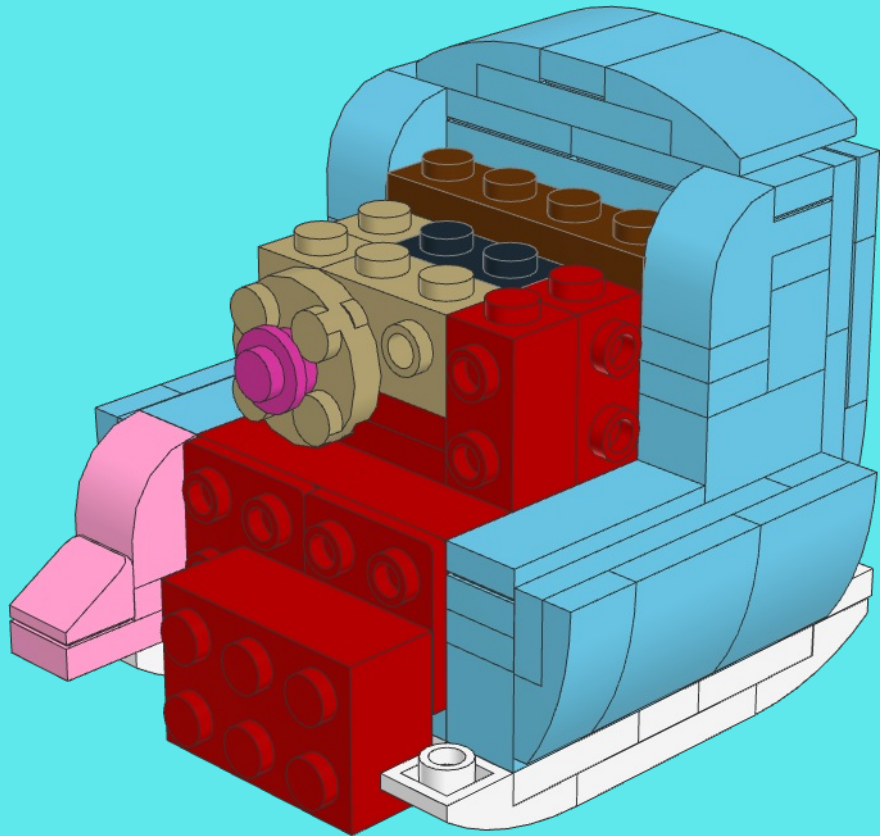



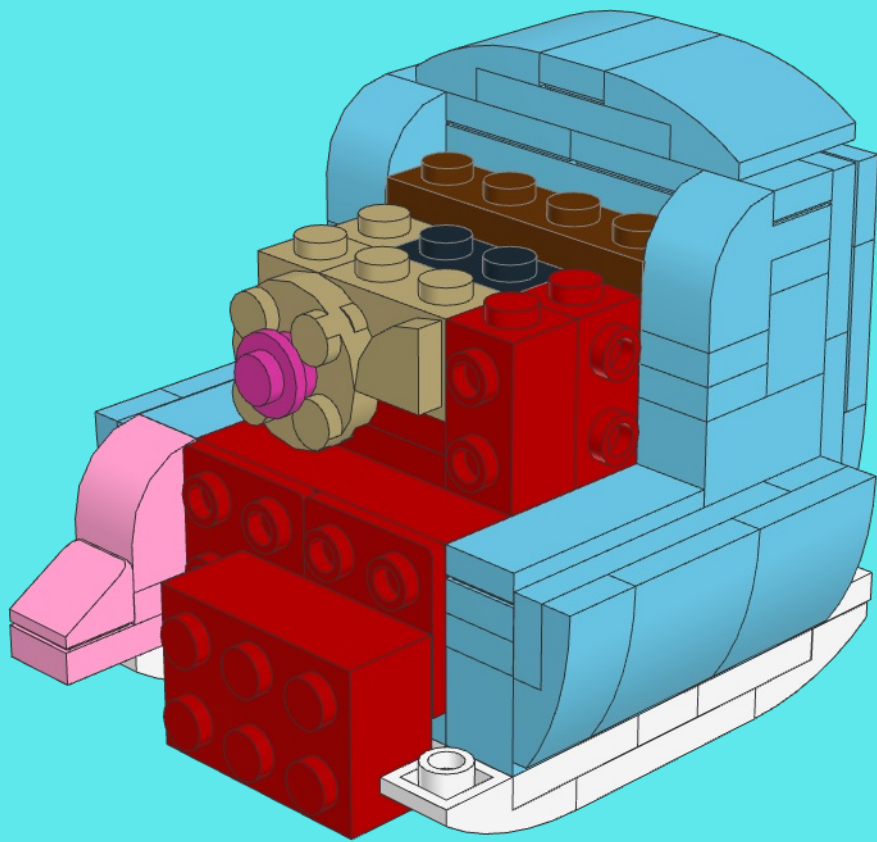

47

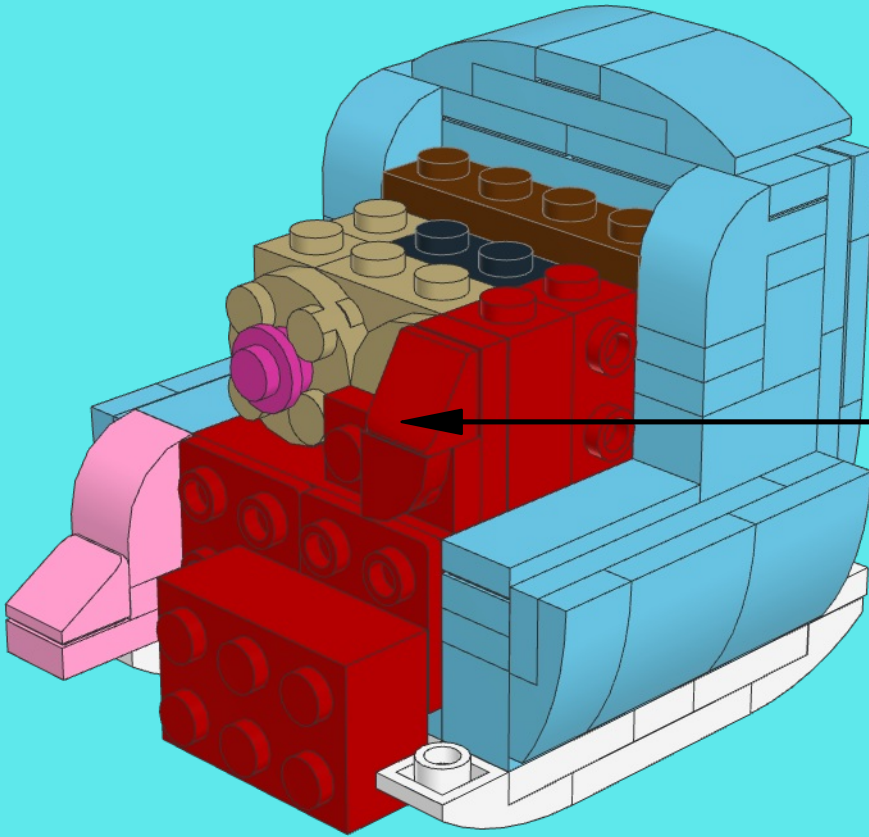

48

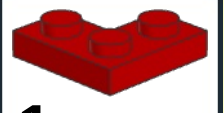
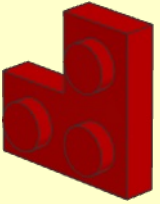
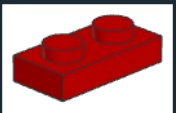
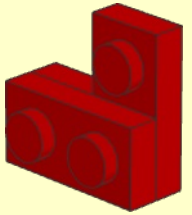

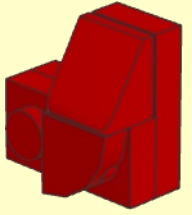
- 1  1x
- 
- 2  1x
- 
- 3  1x  1x
- 

49

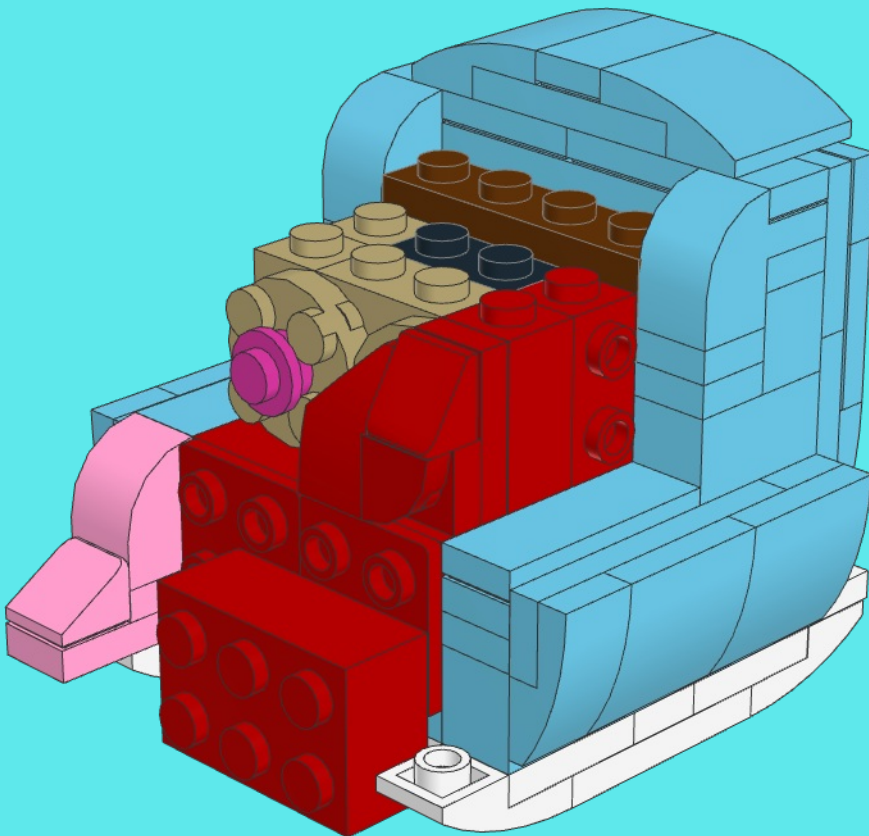

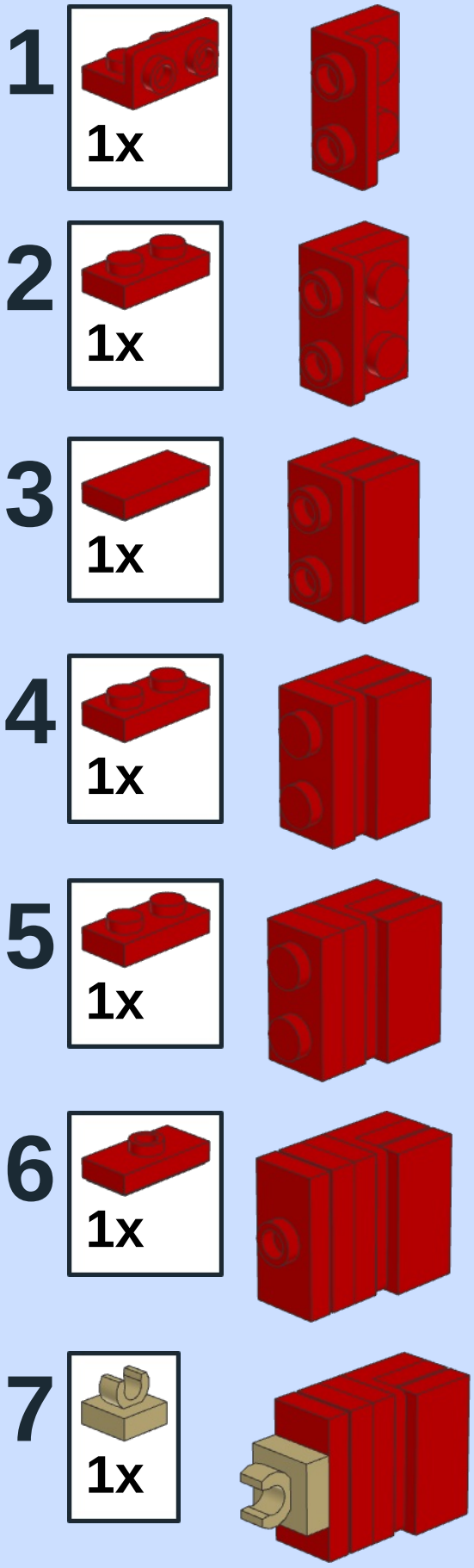

x2

50

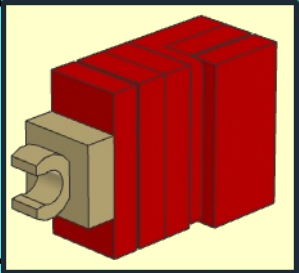
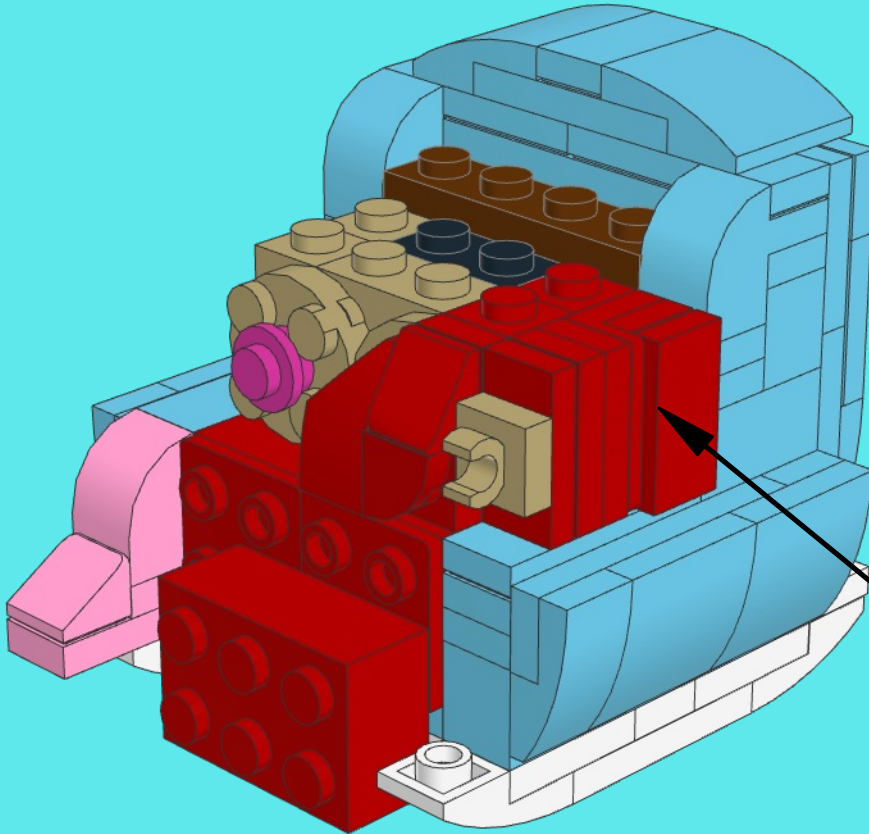

51

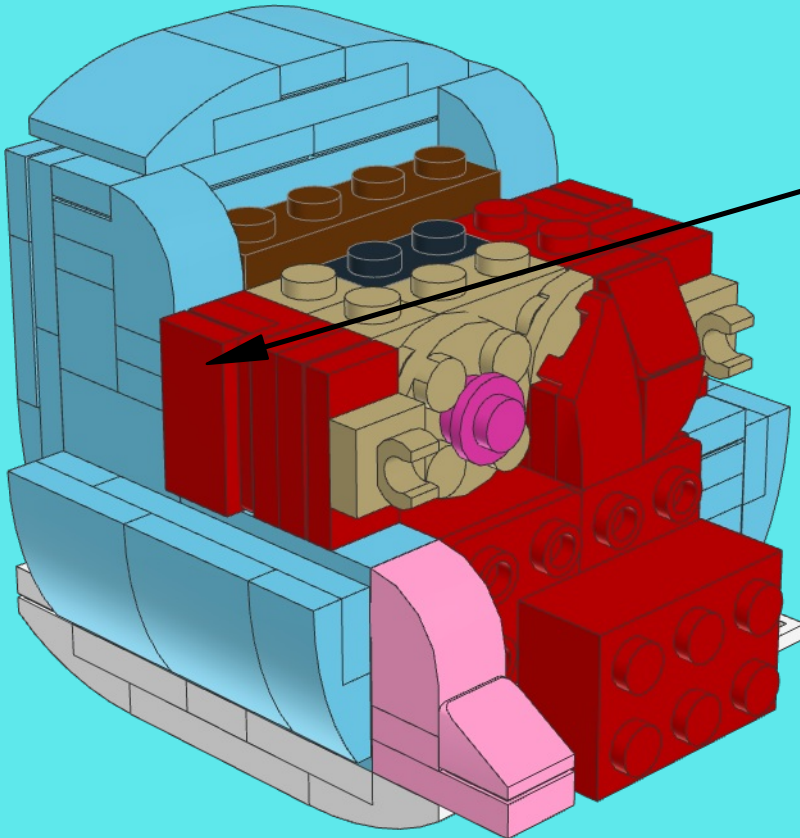

52

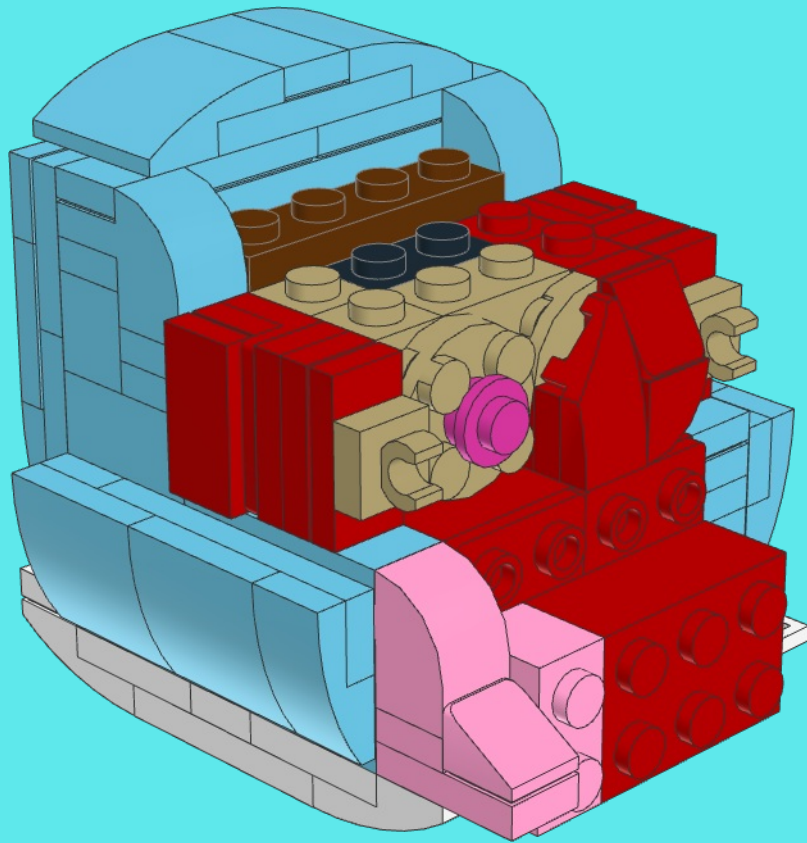
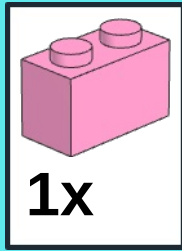

53

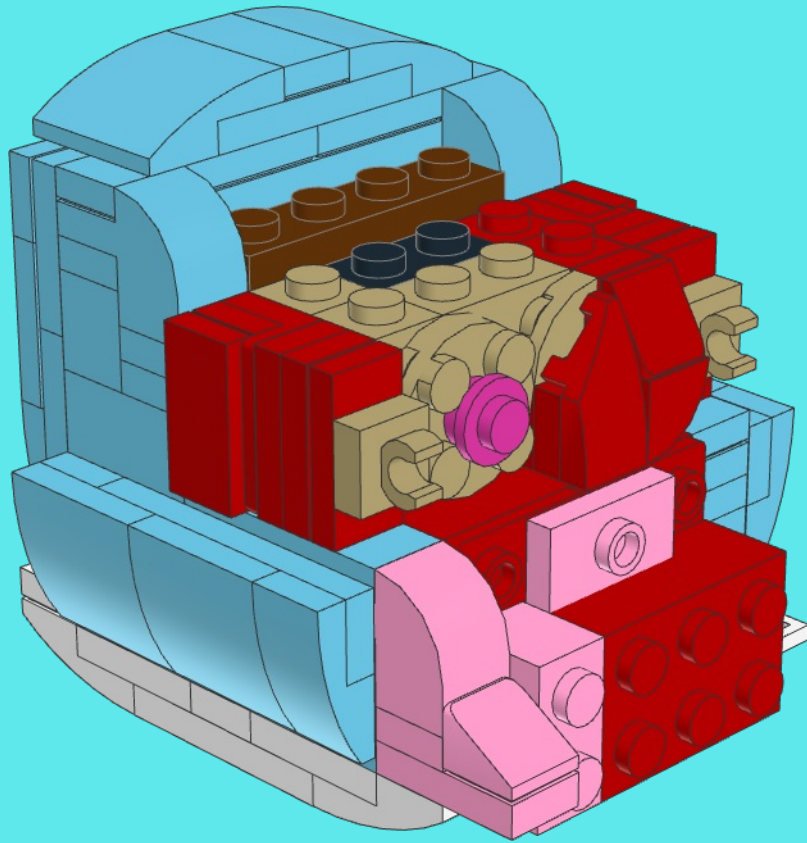
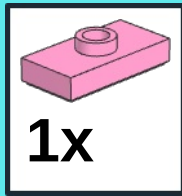

54

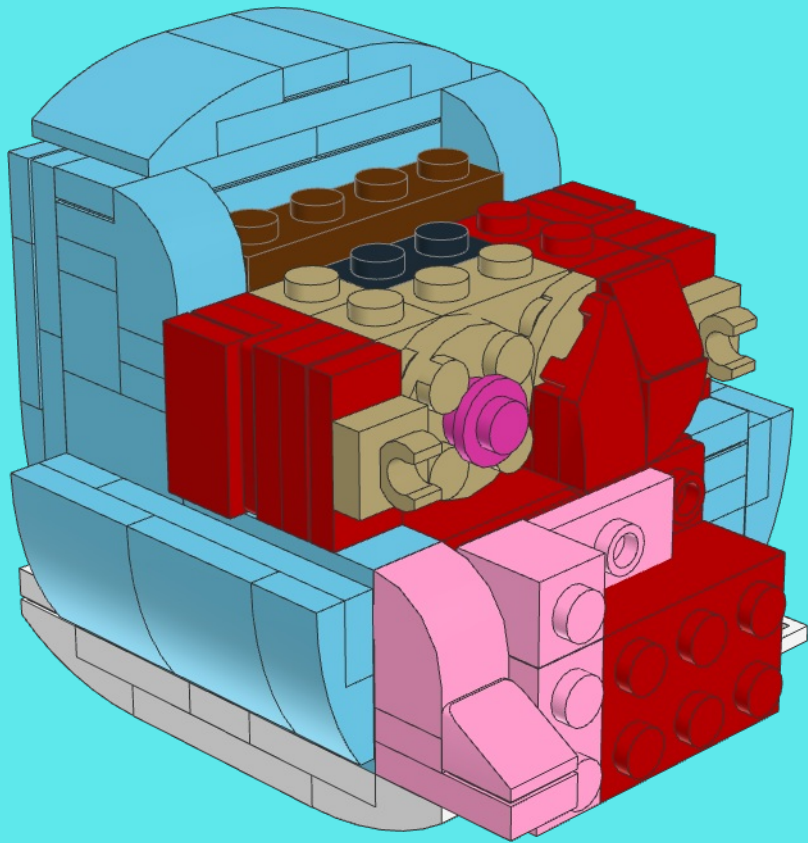
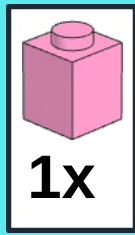

55

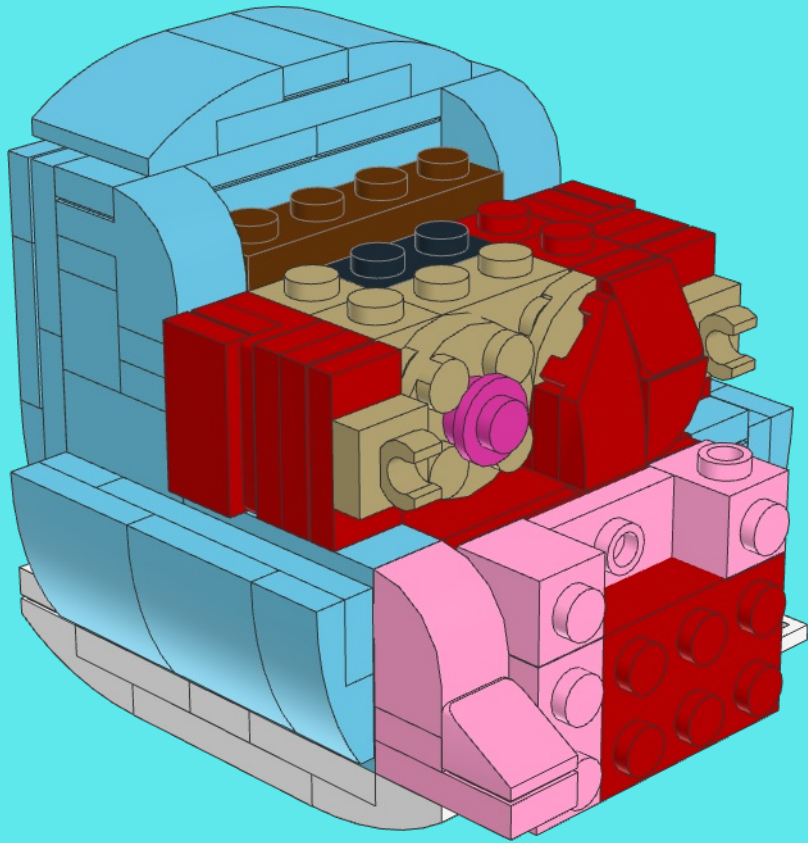
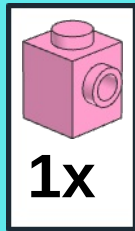

56

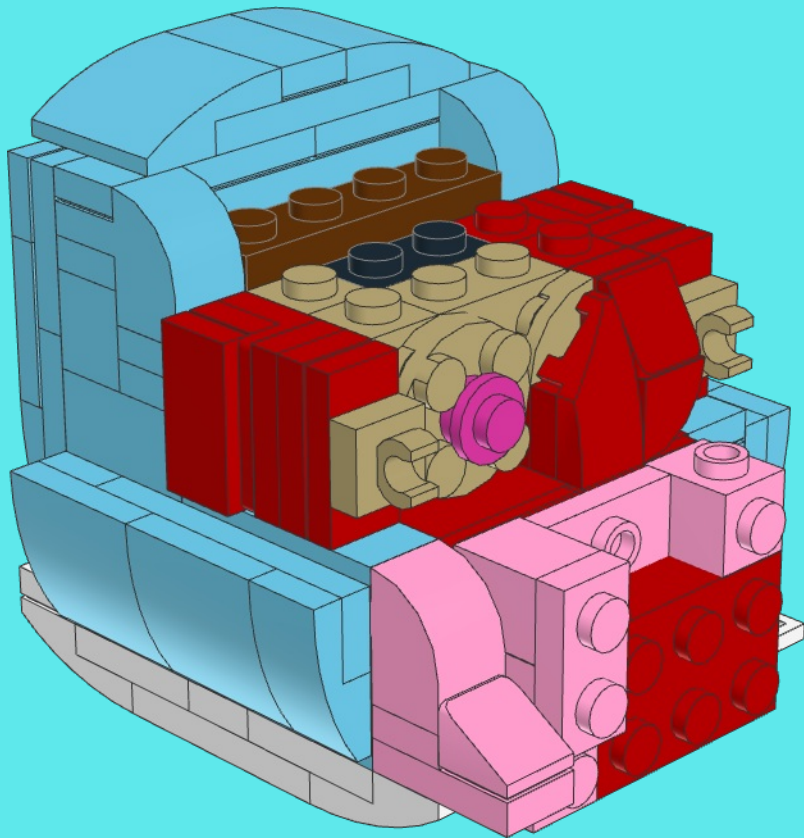
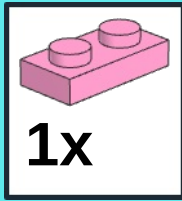

57

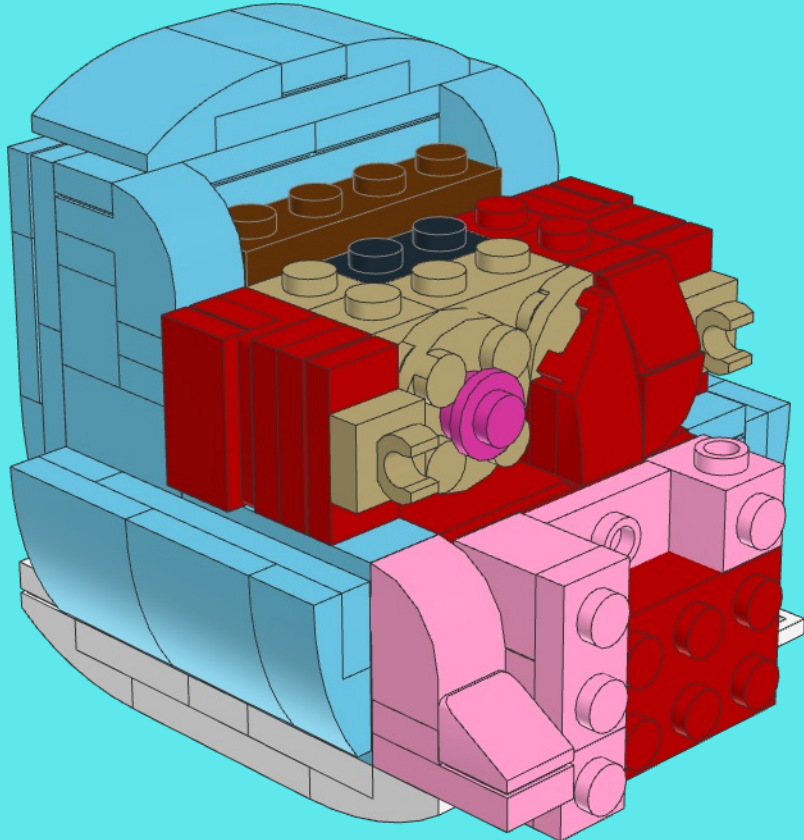
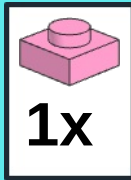

58

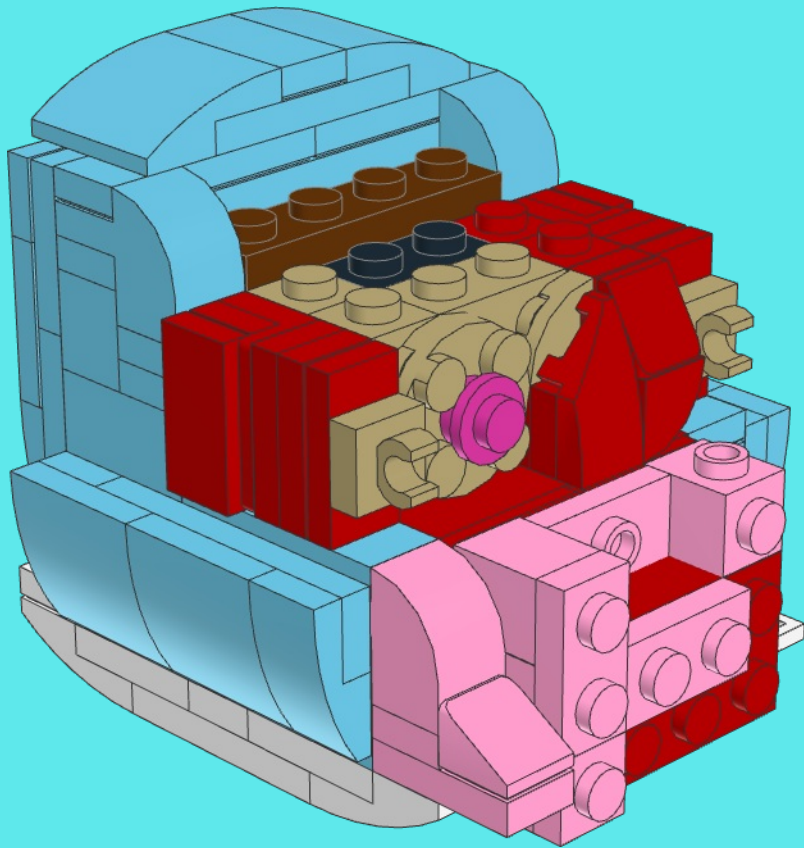
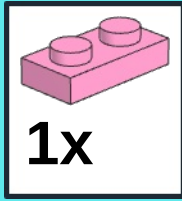

59

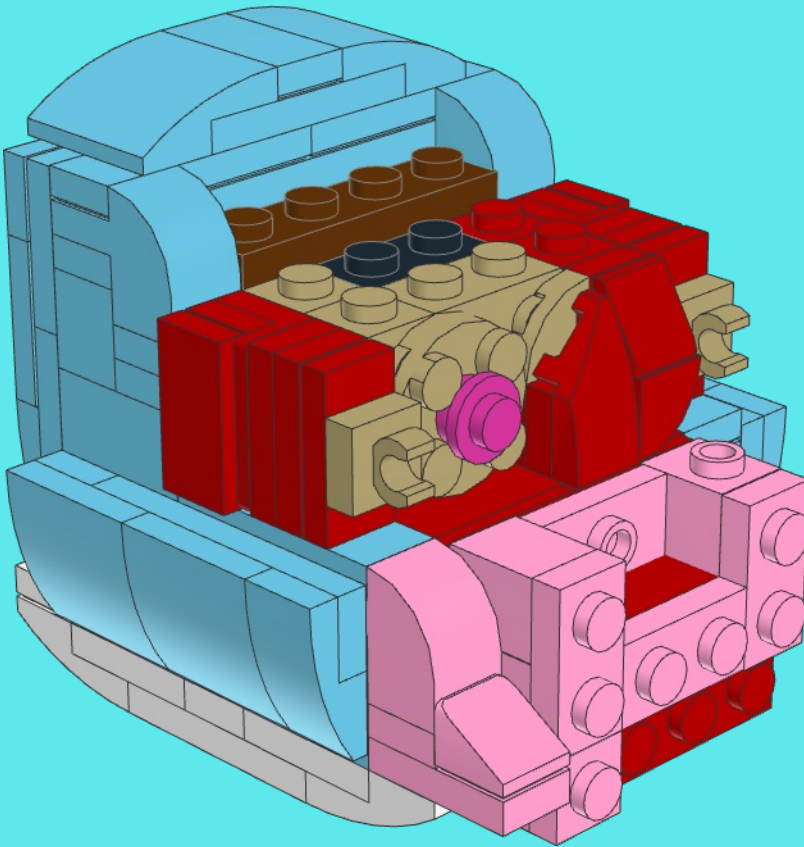
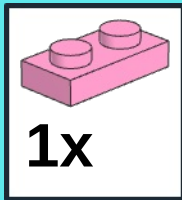



60

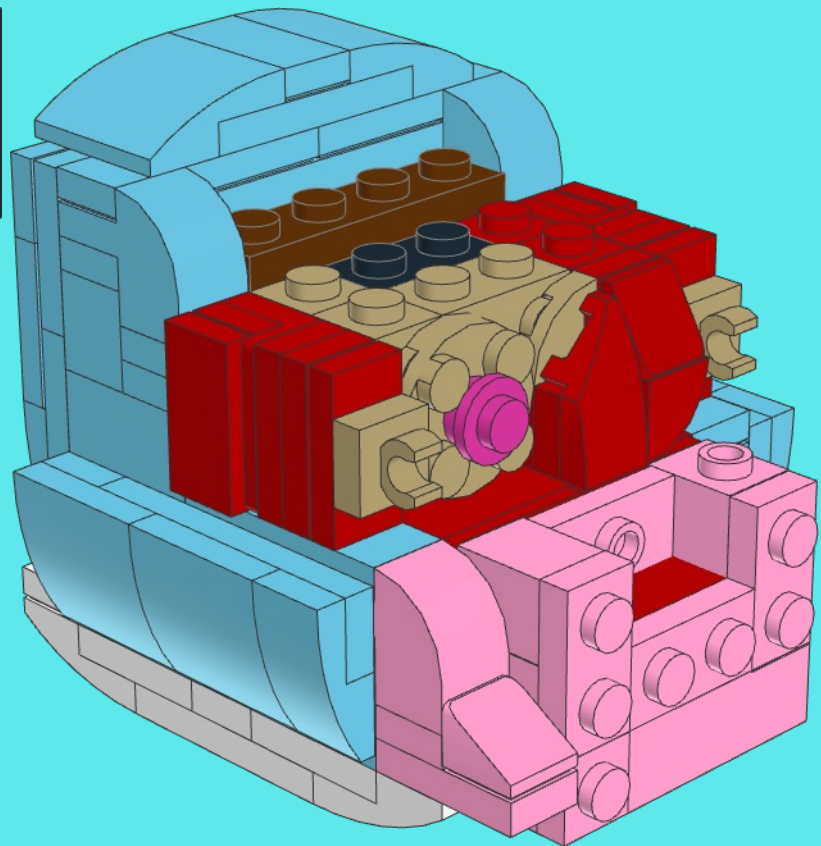
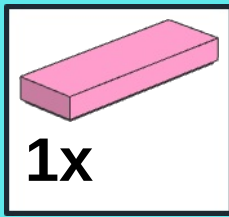

61

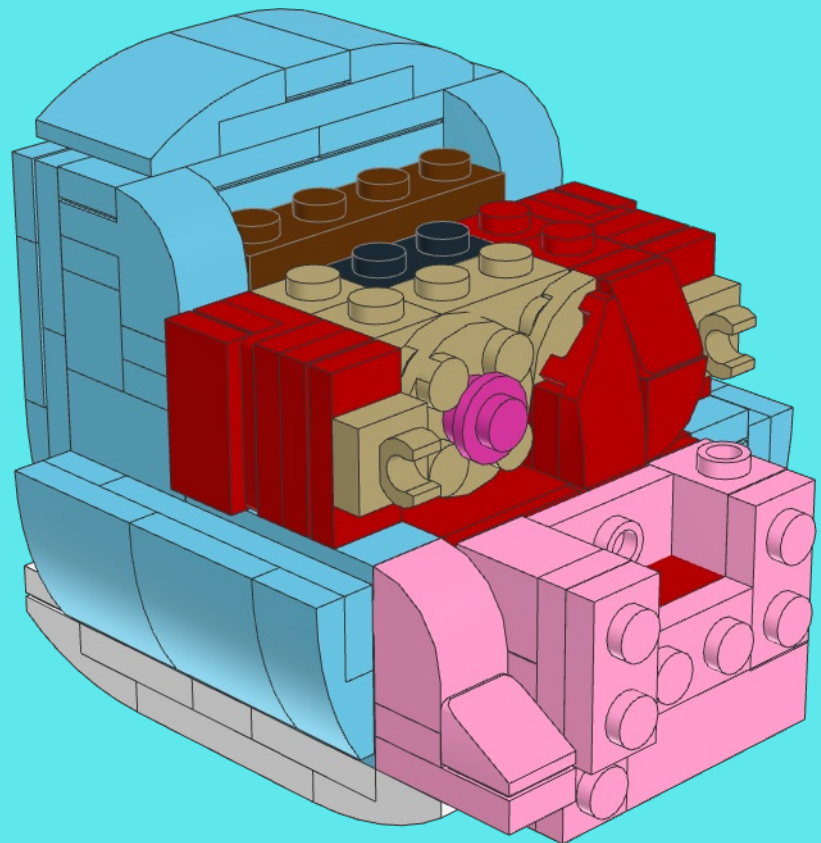
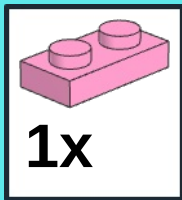

62

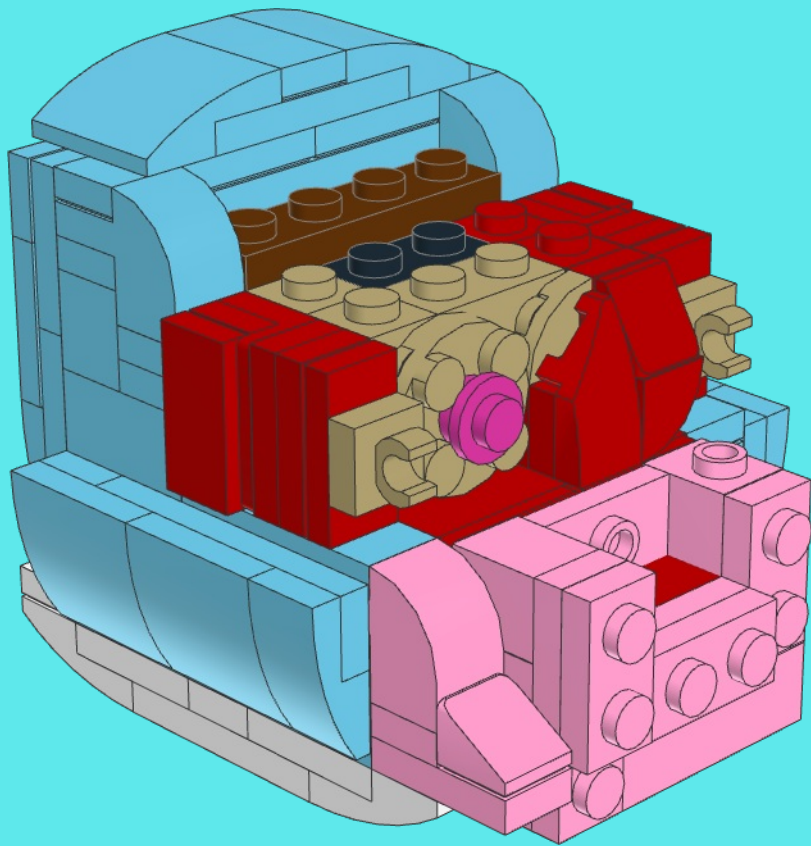
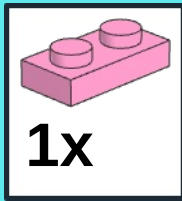

63

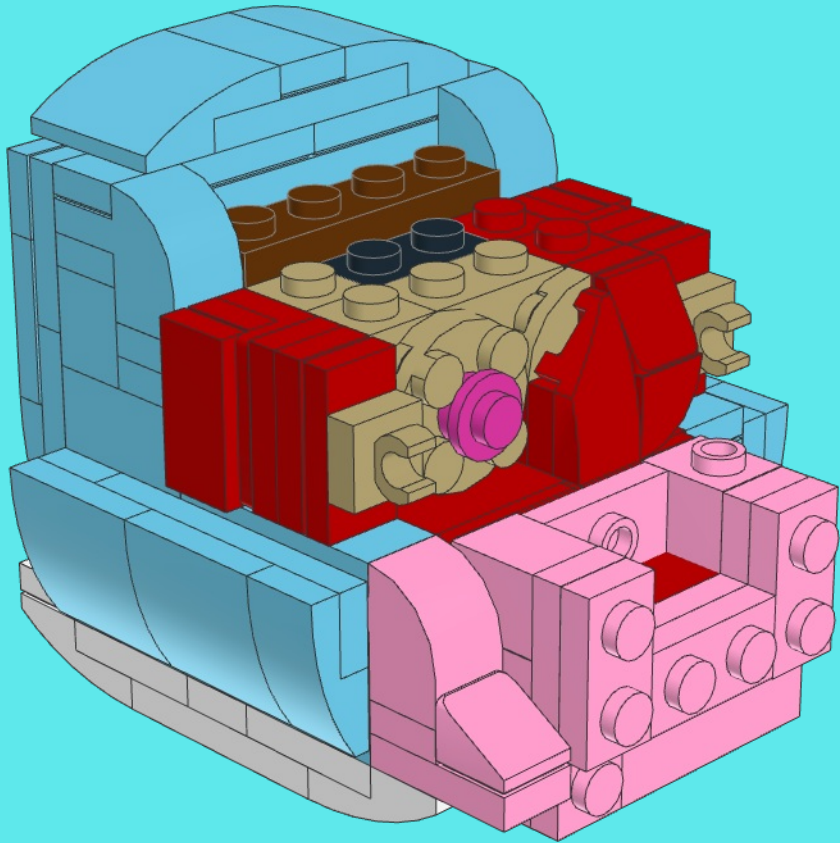
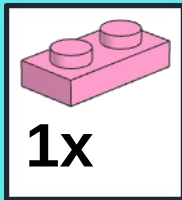

64

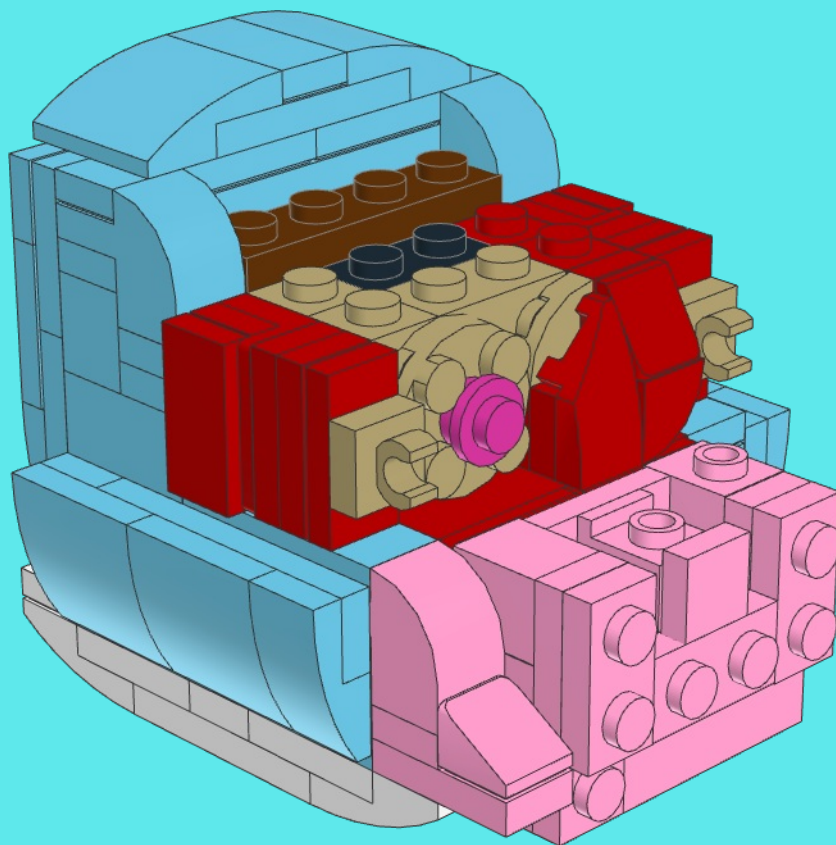
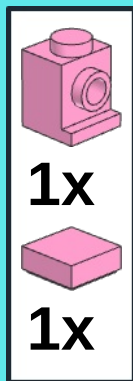

65

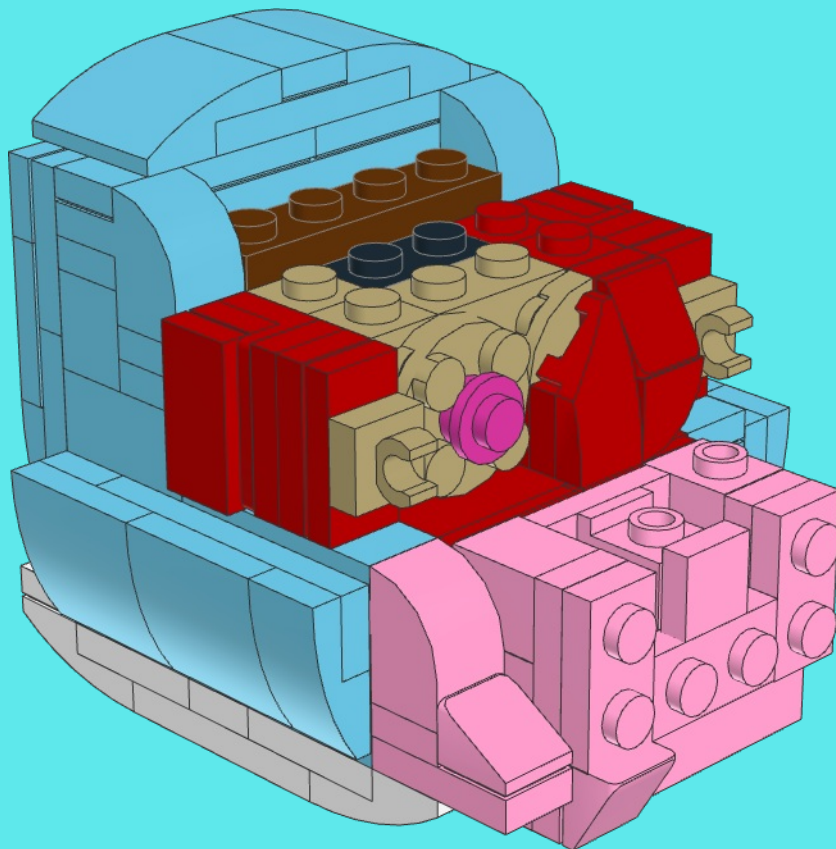
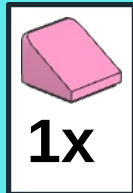

66

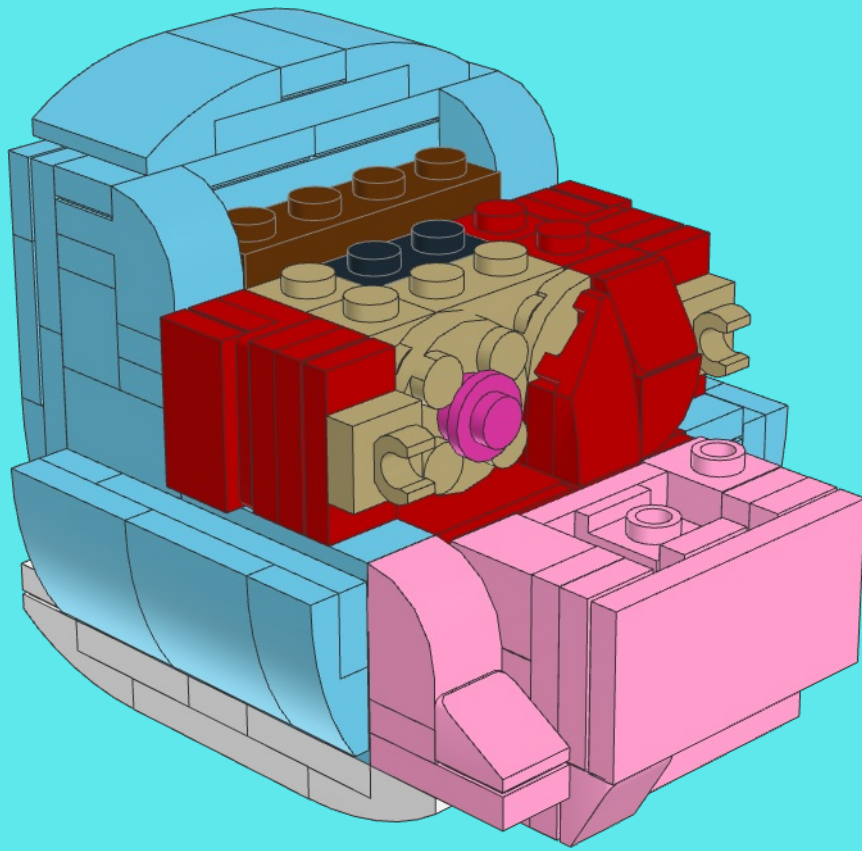
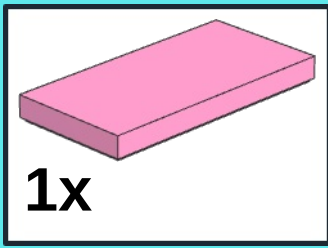

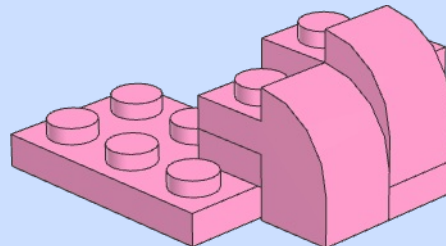
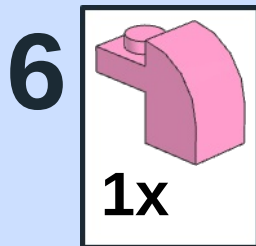
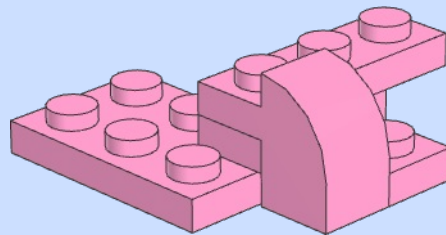
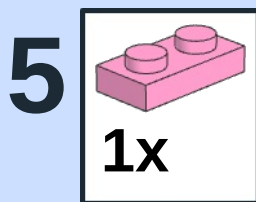
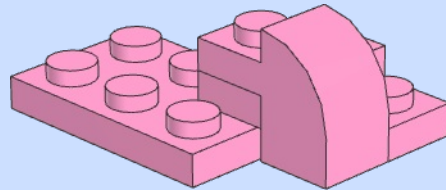
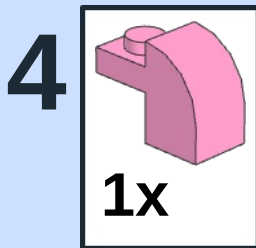
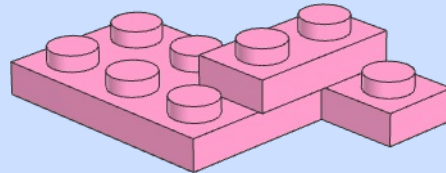
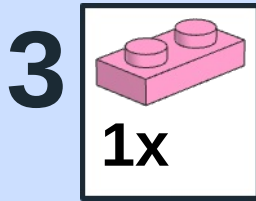
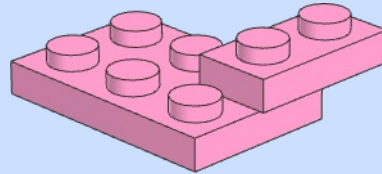
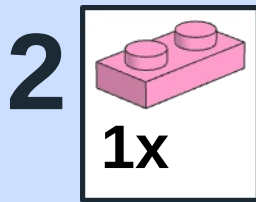
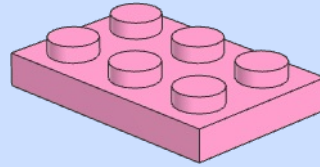
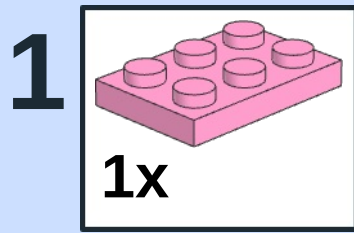

7

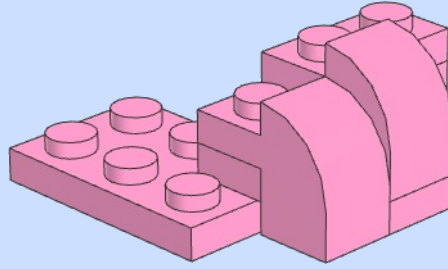
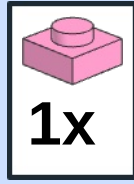

8

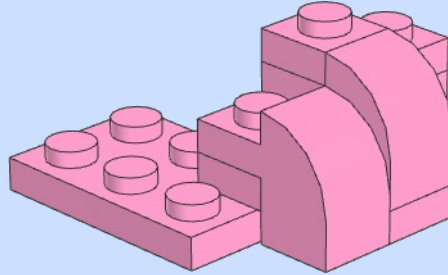
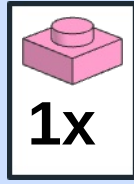

9

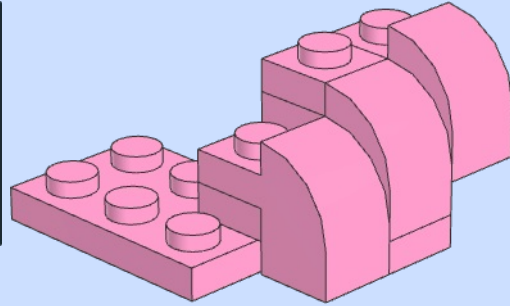
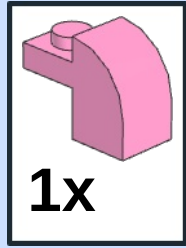

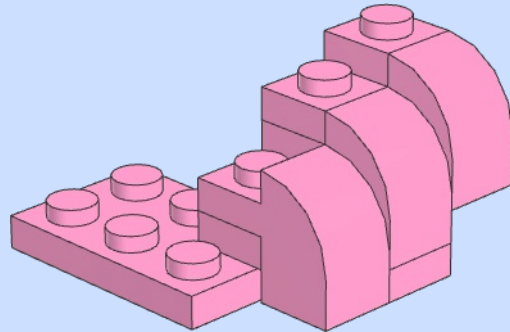
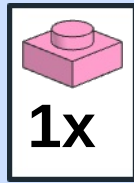

10



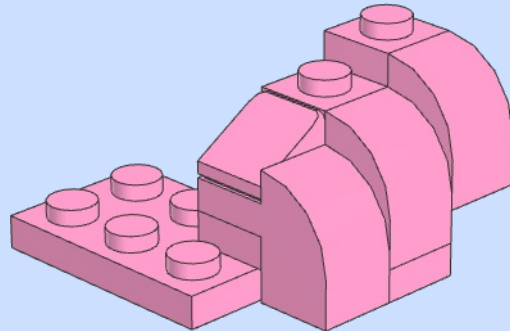
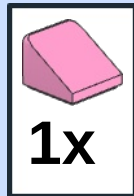

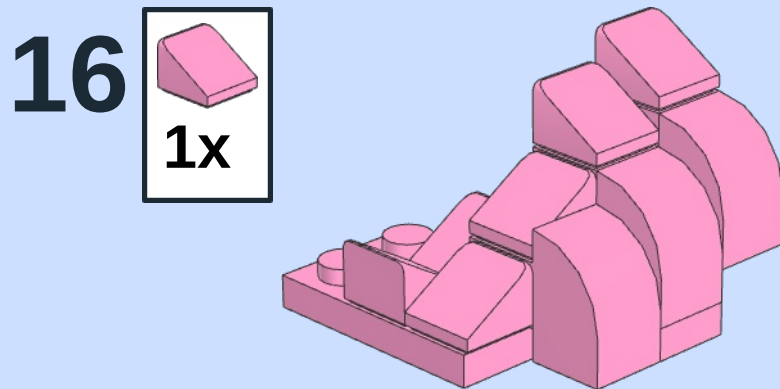
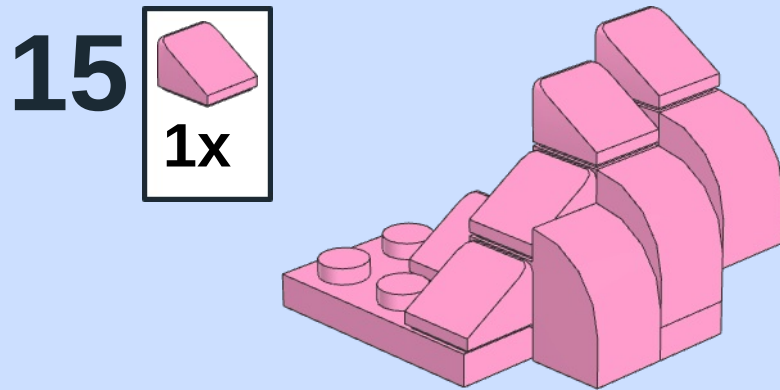
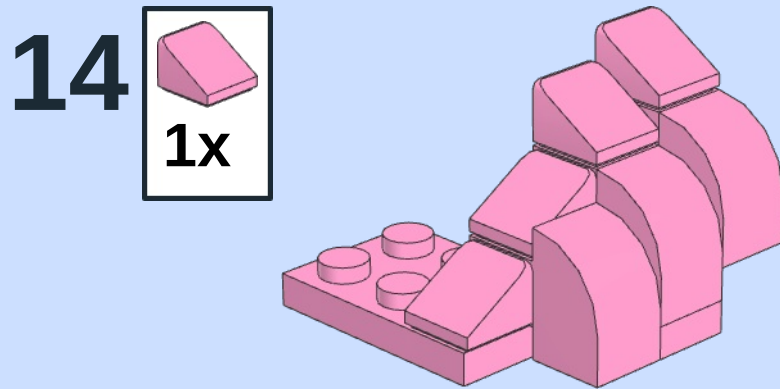
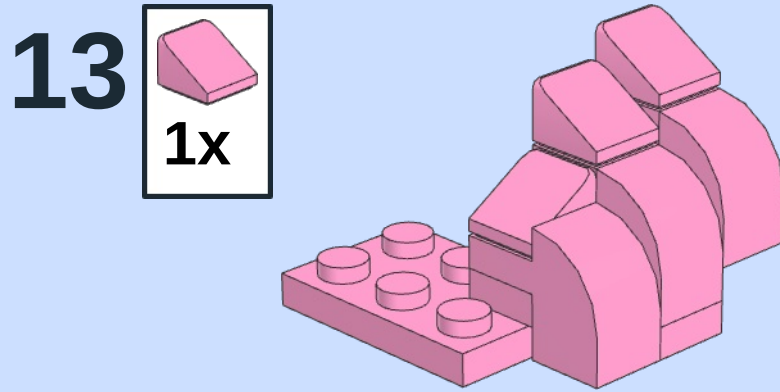
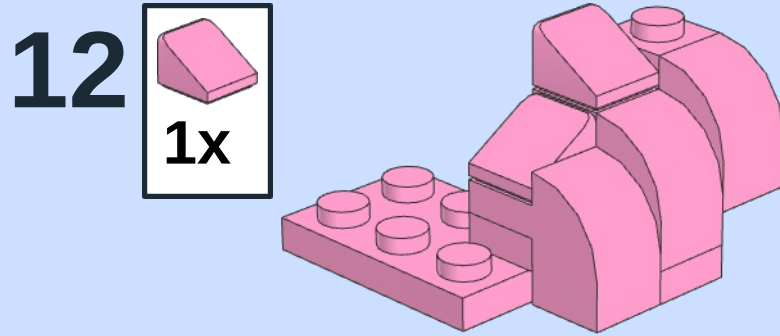
11





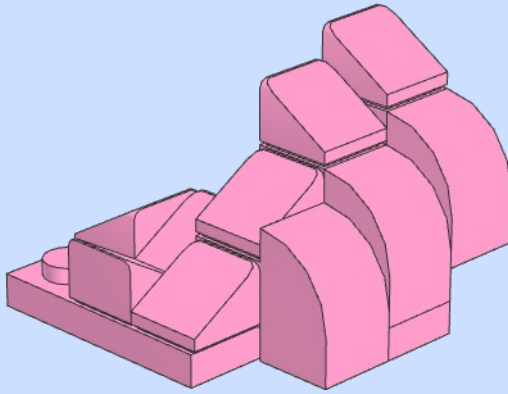

**17**   
**1x**

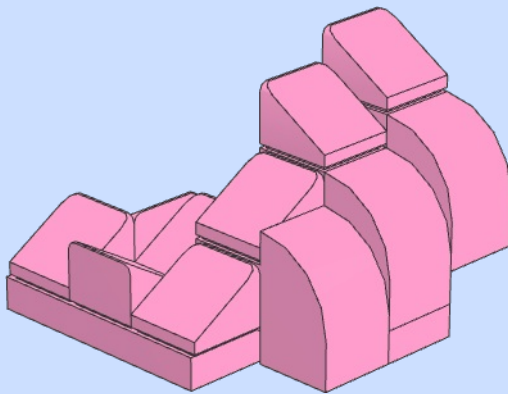

**18**   
**1x**



**19**   
**1x**

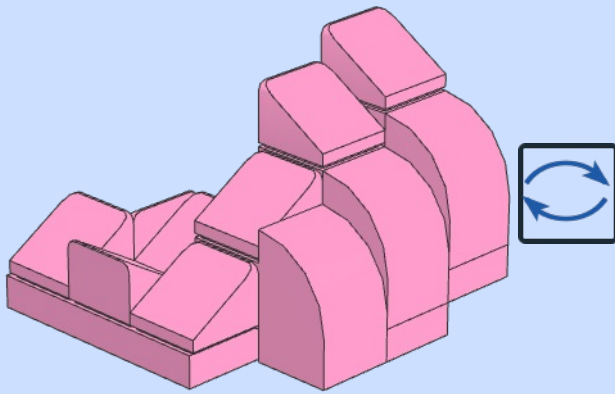

**20**   
**1x**

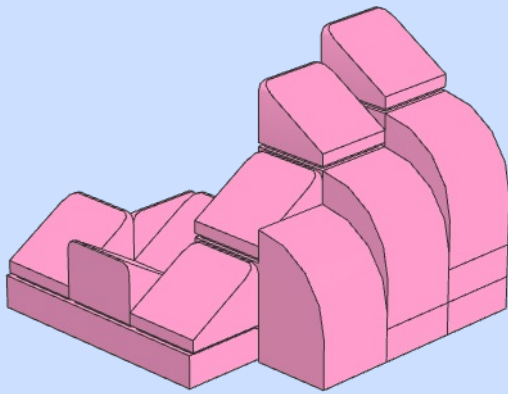



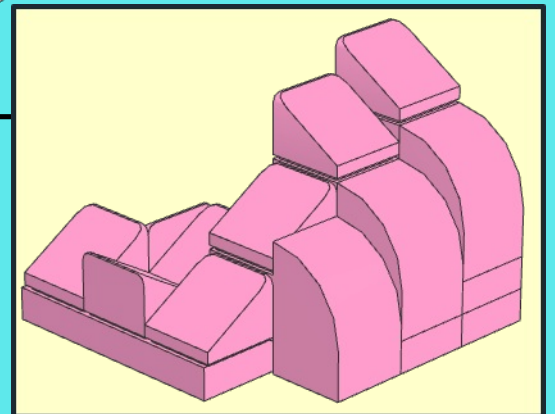
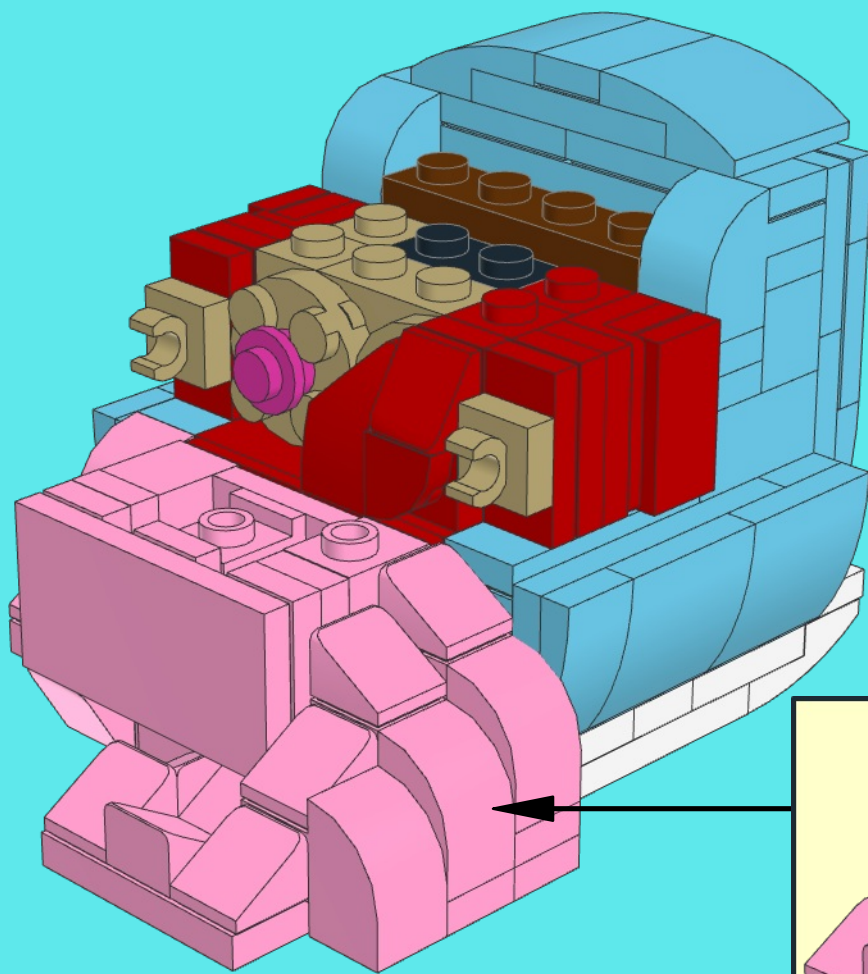

68

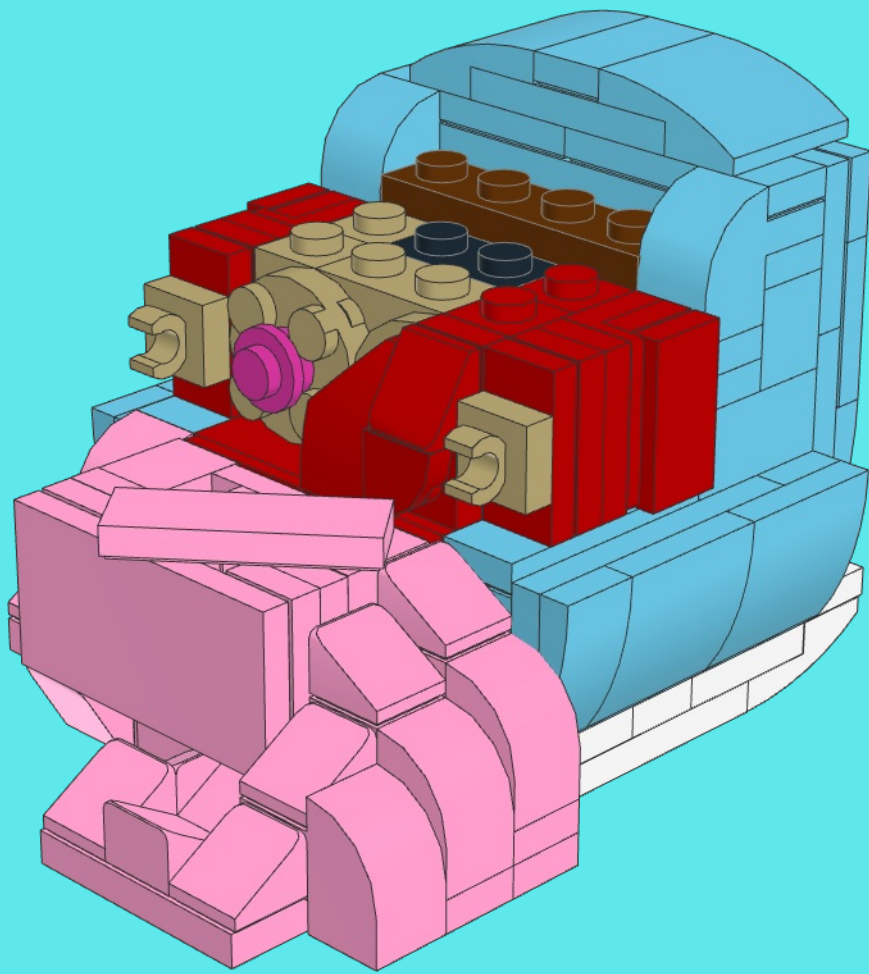
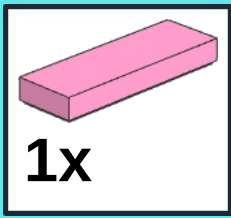

69

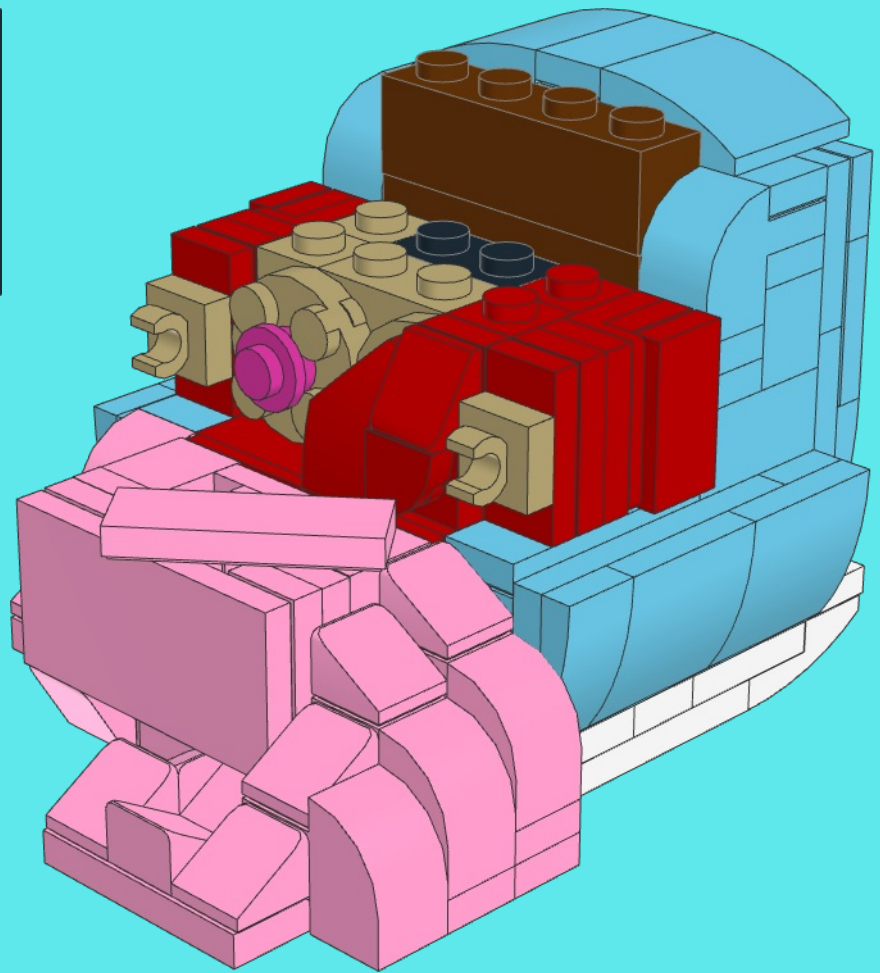
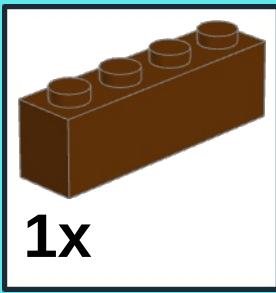

70

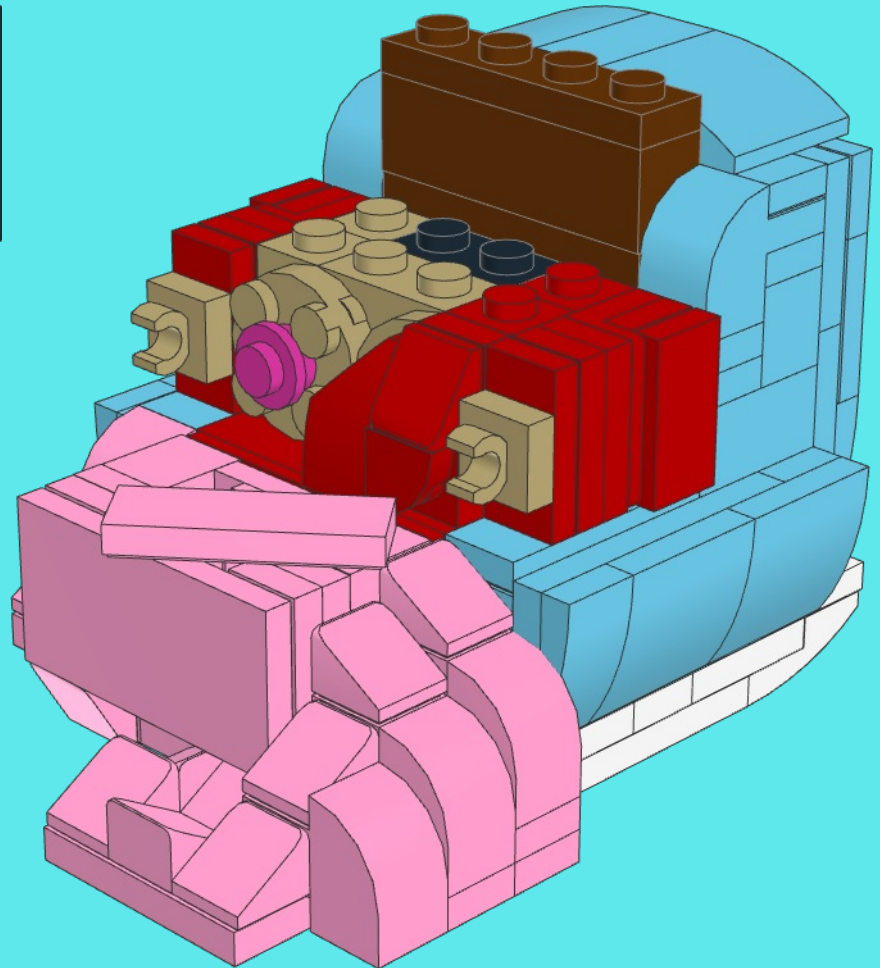
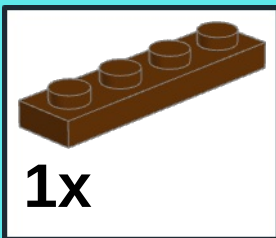

71

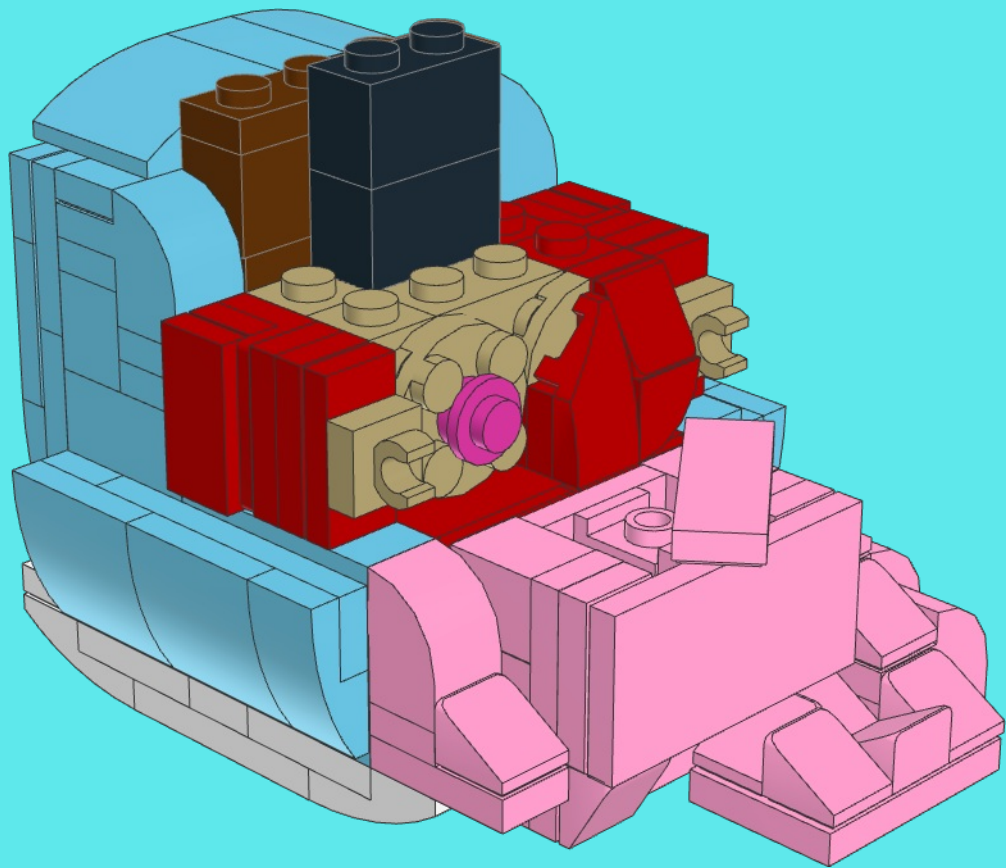
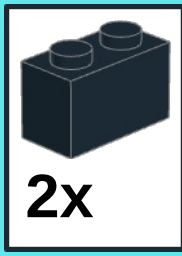

72

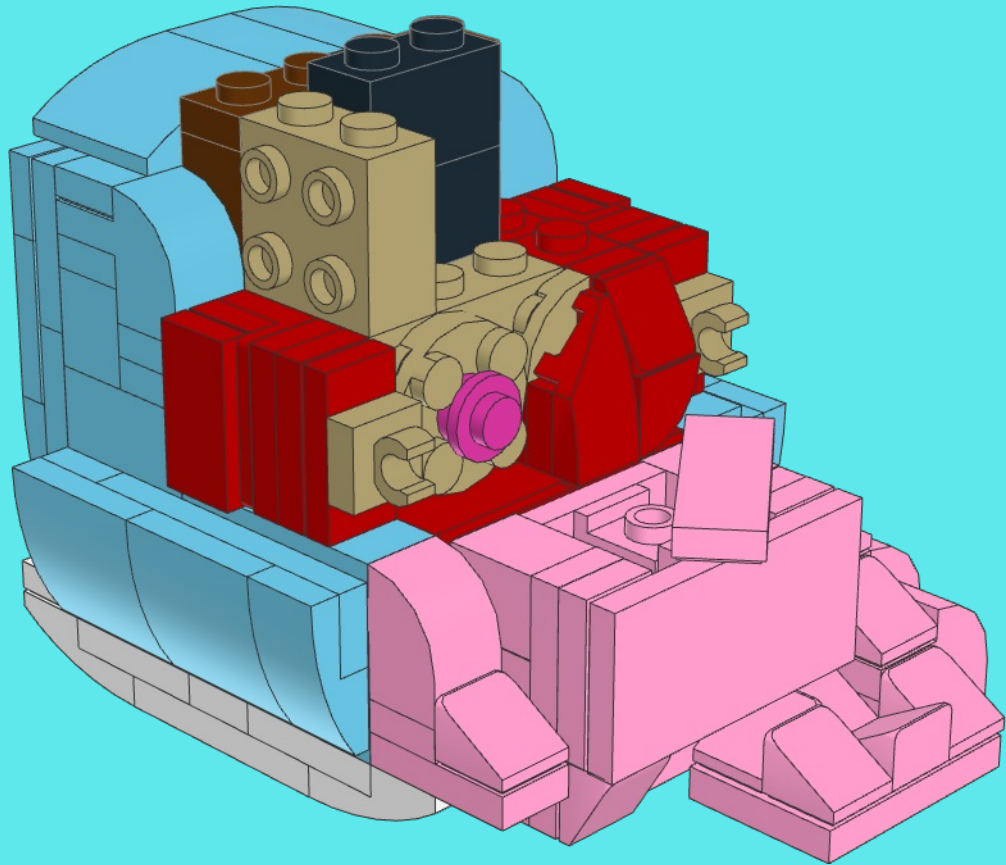
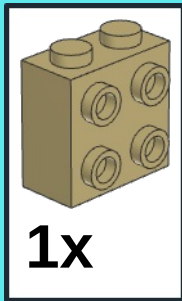

73

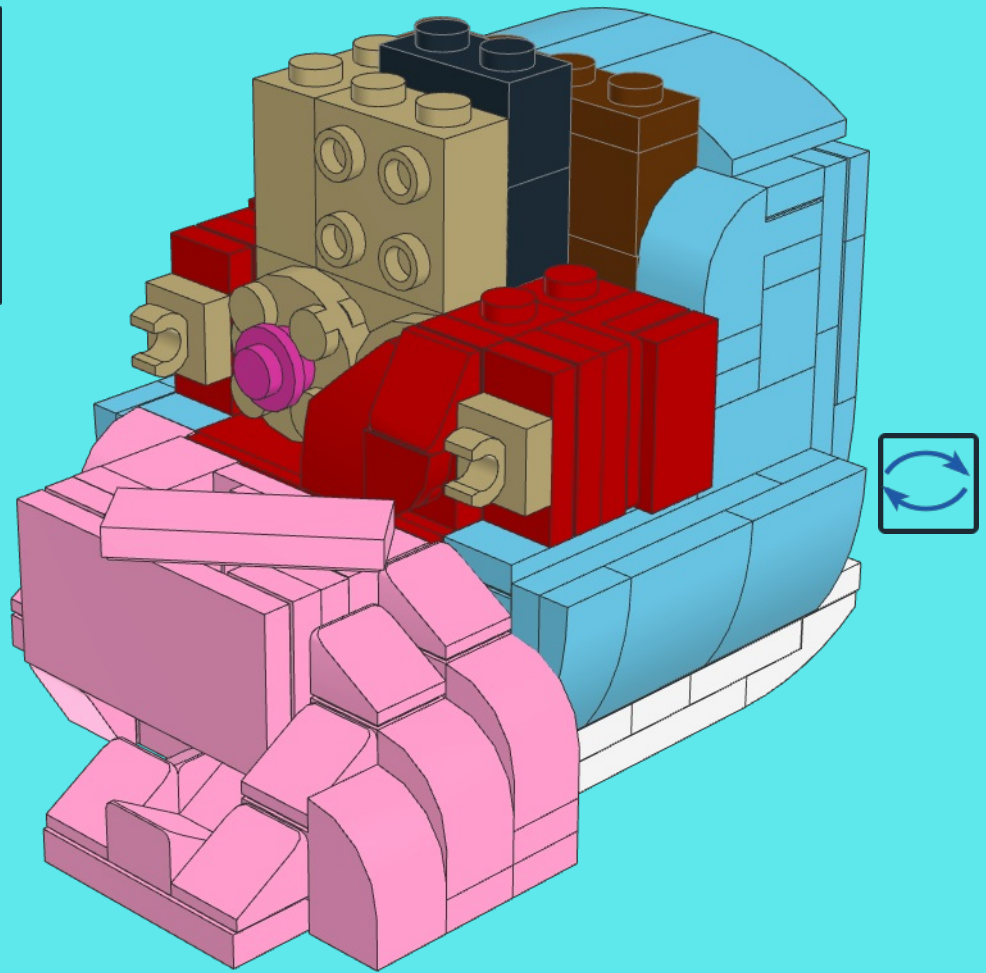
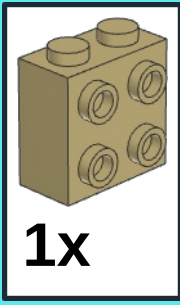

74

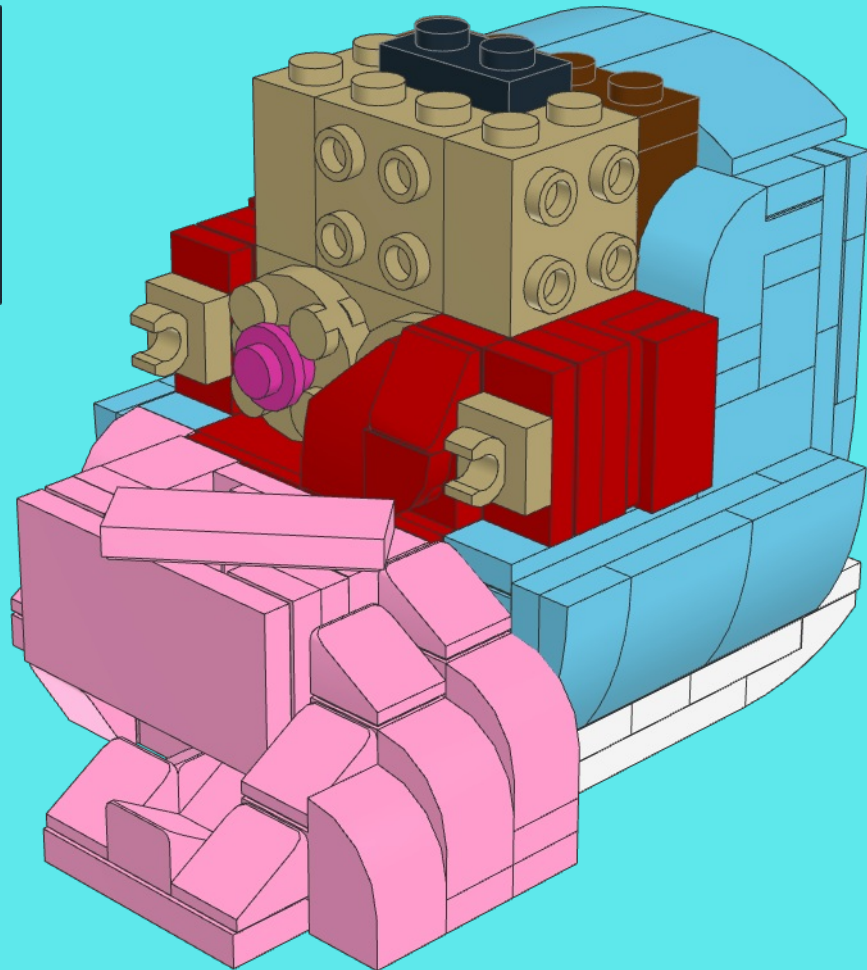
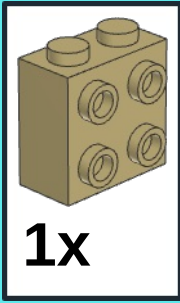

75

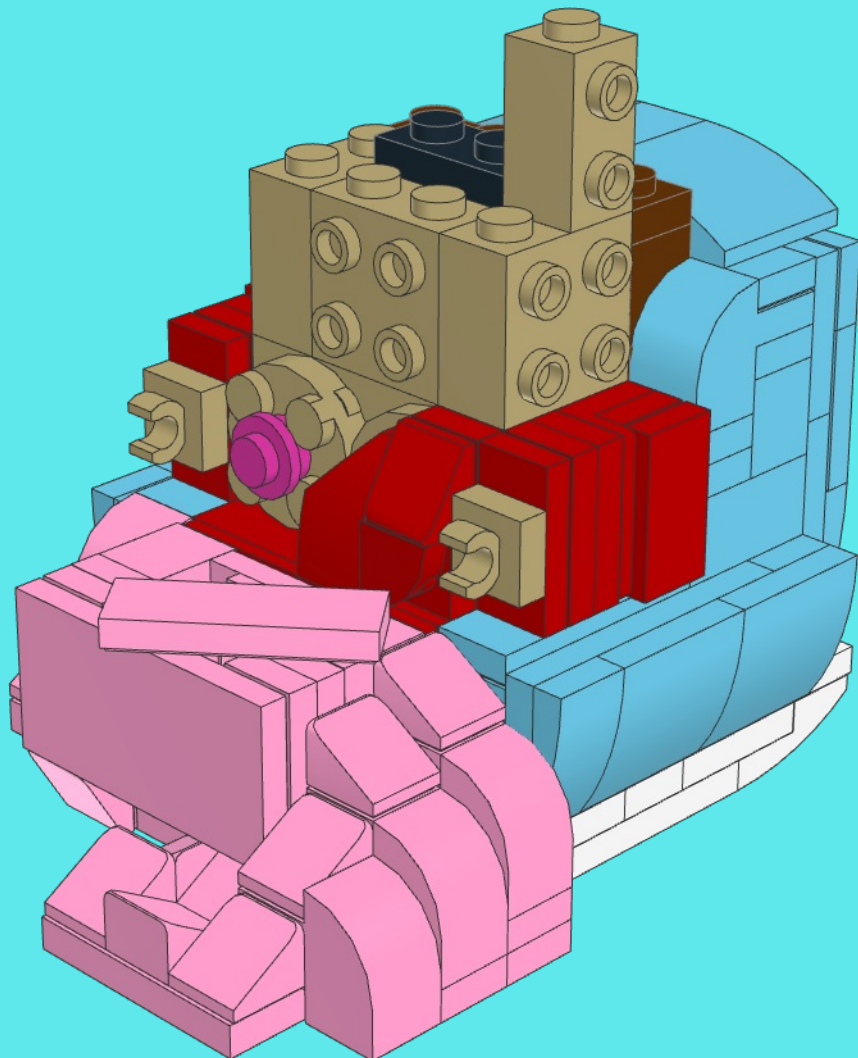
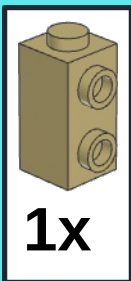

76

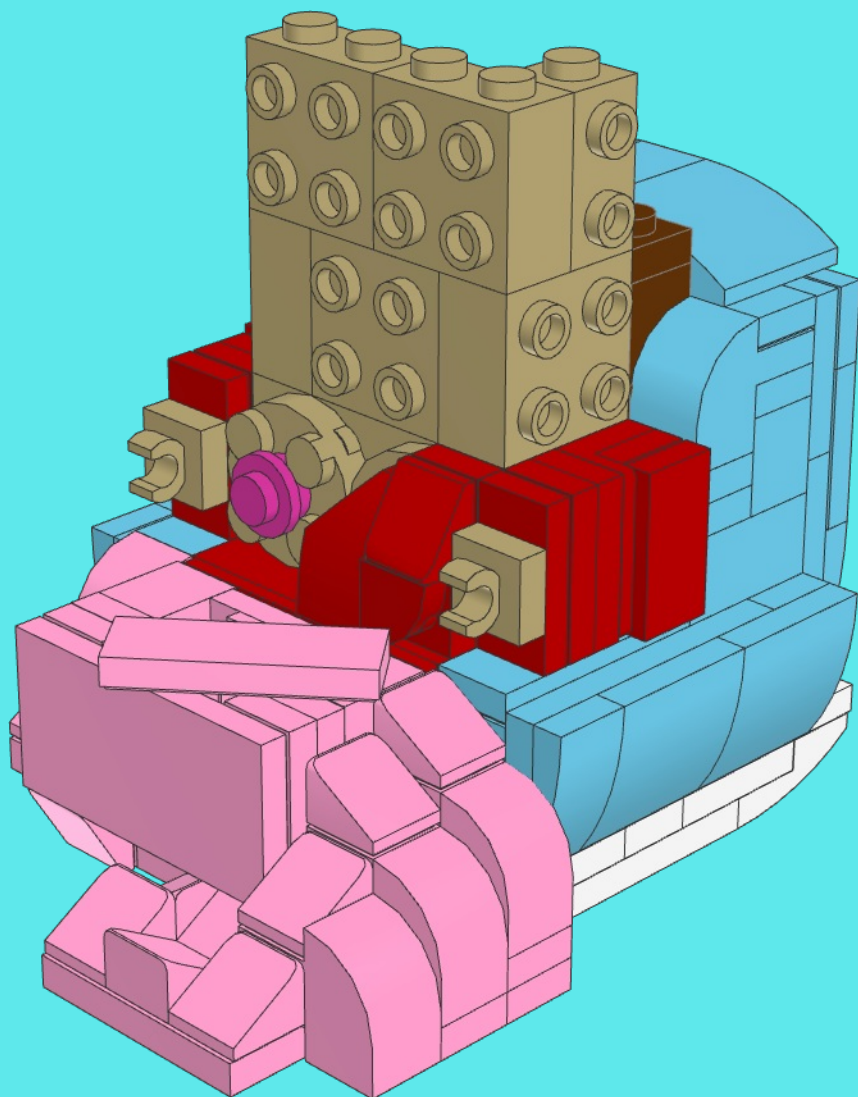
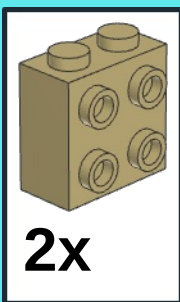

77

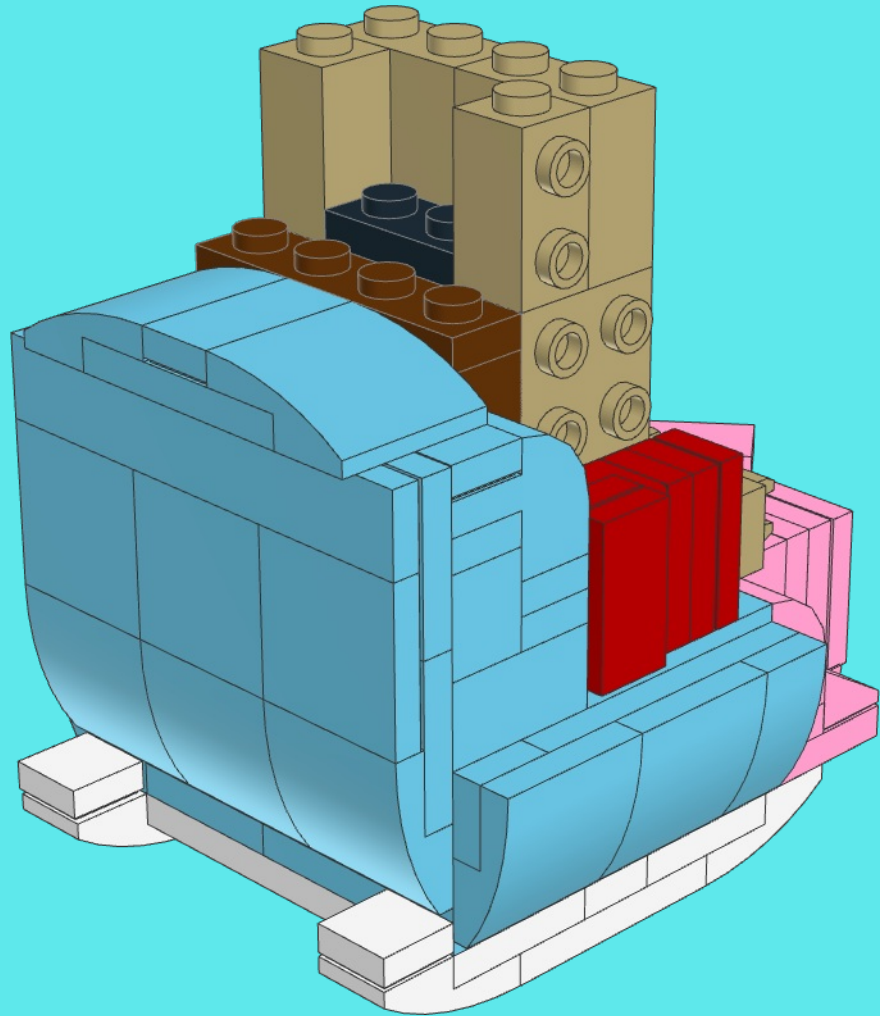
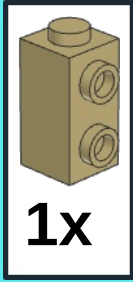

78

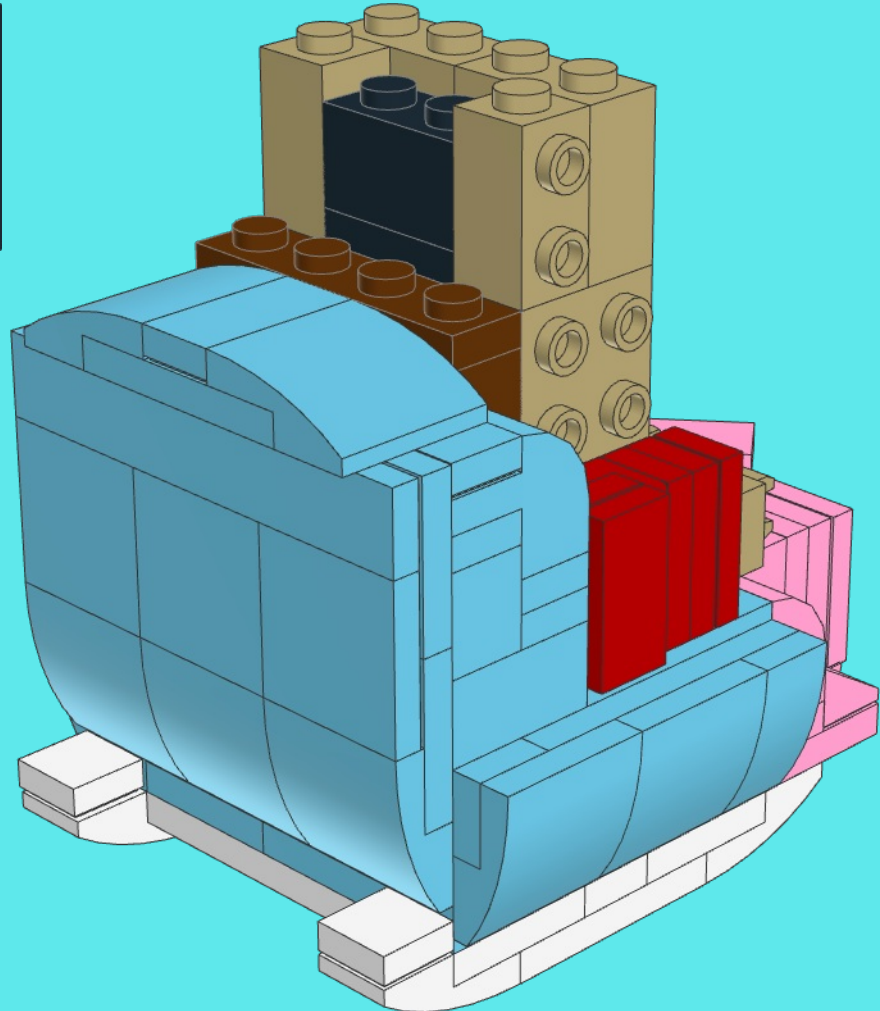
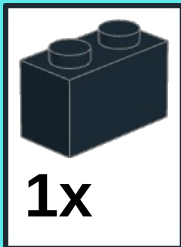

79

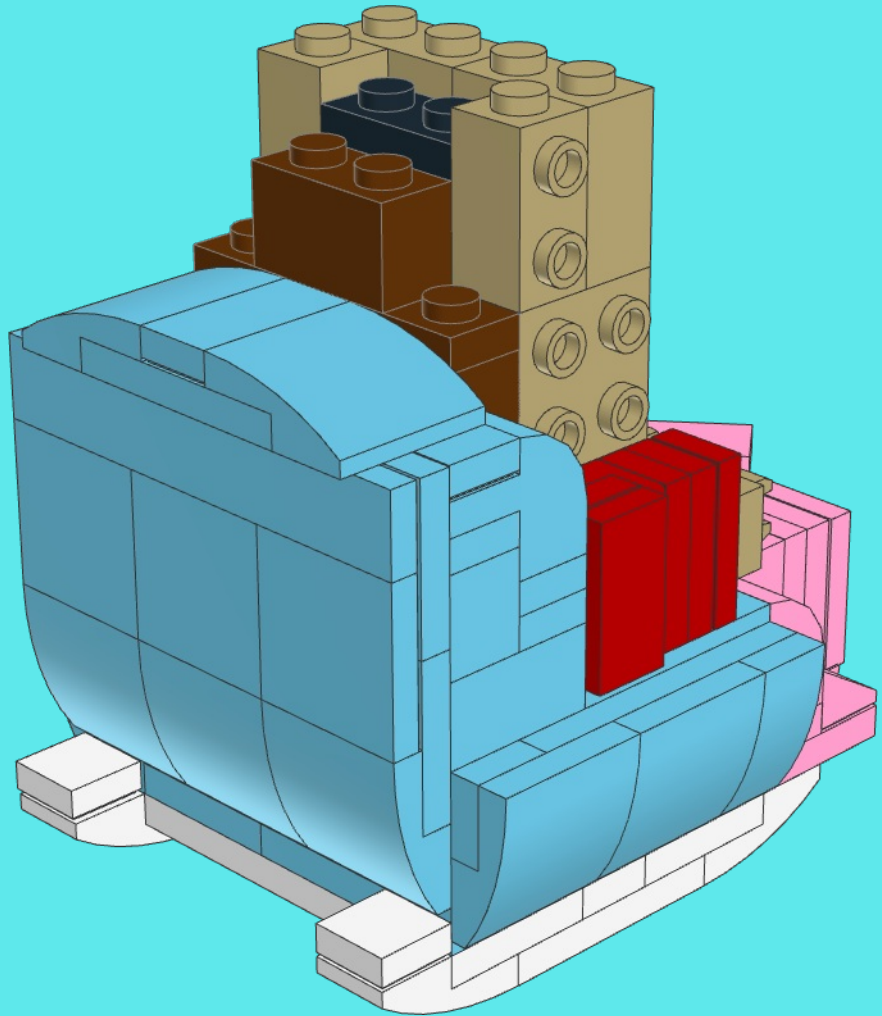
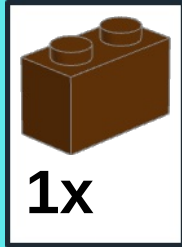

80

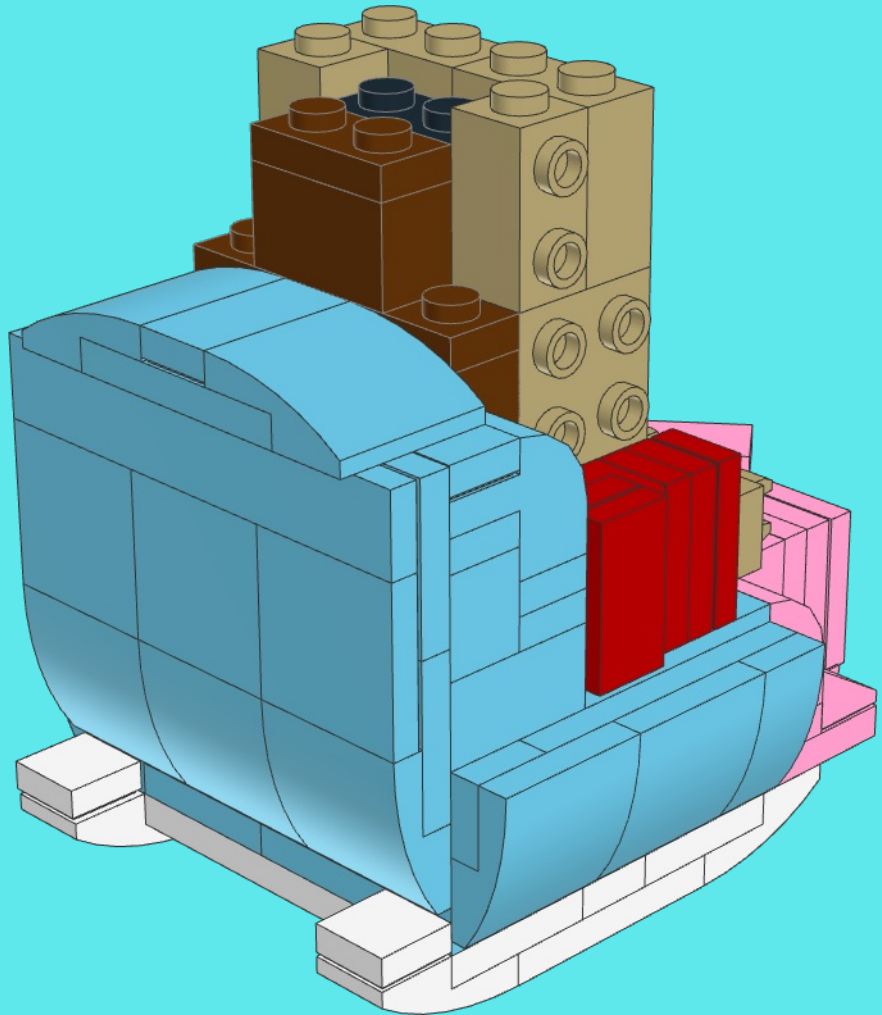
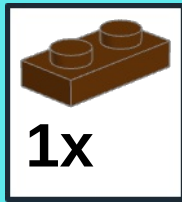



81

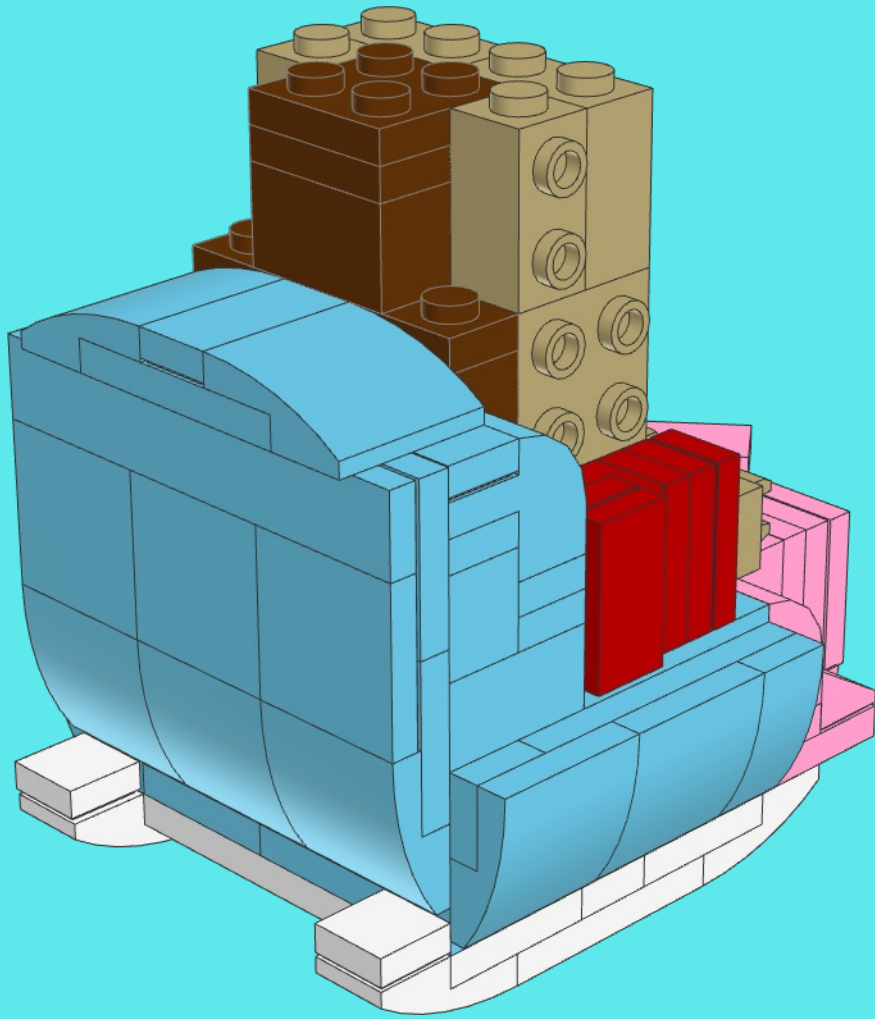
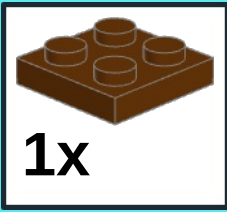

1

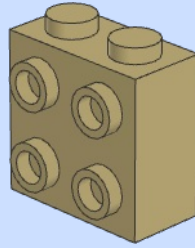
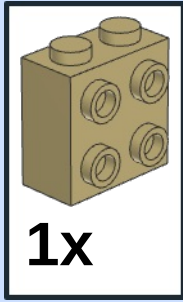

2

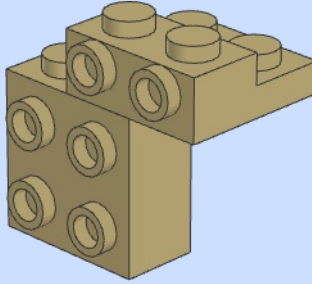
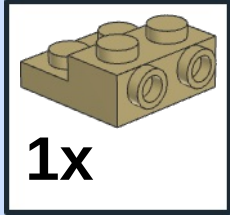

3

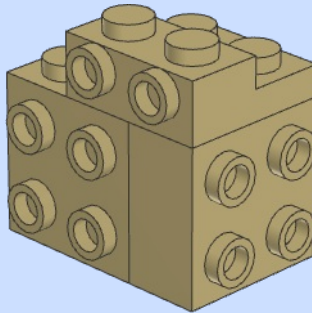
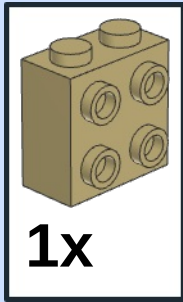

4

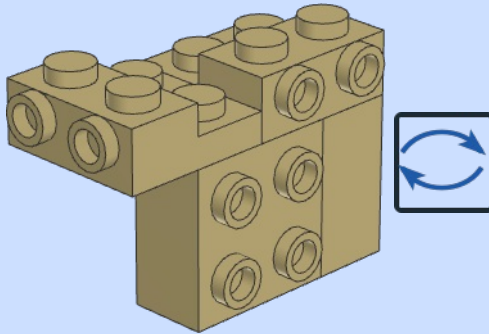
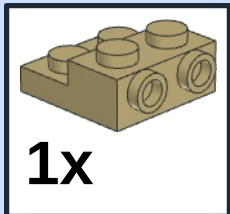

5

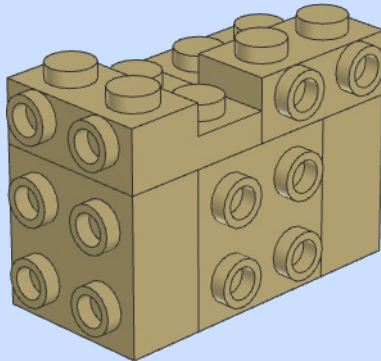
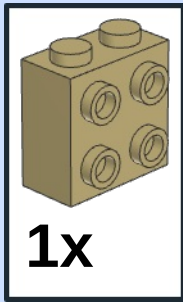

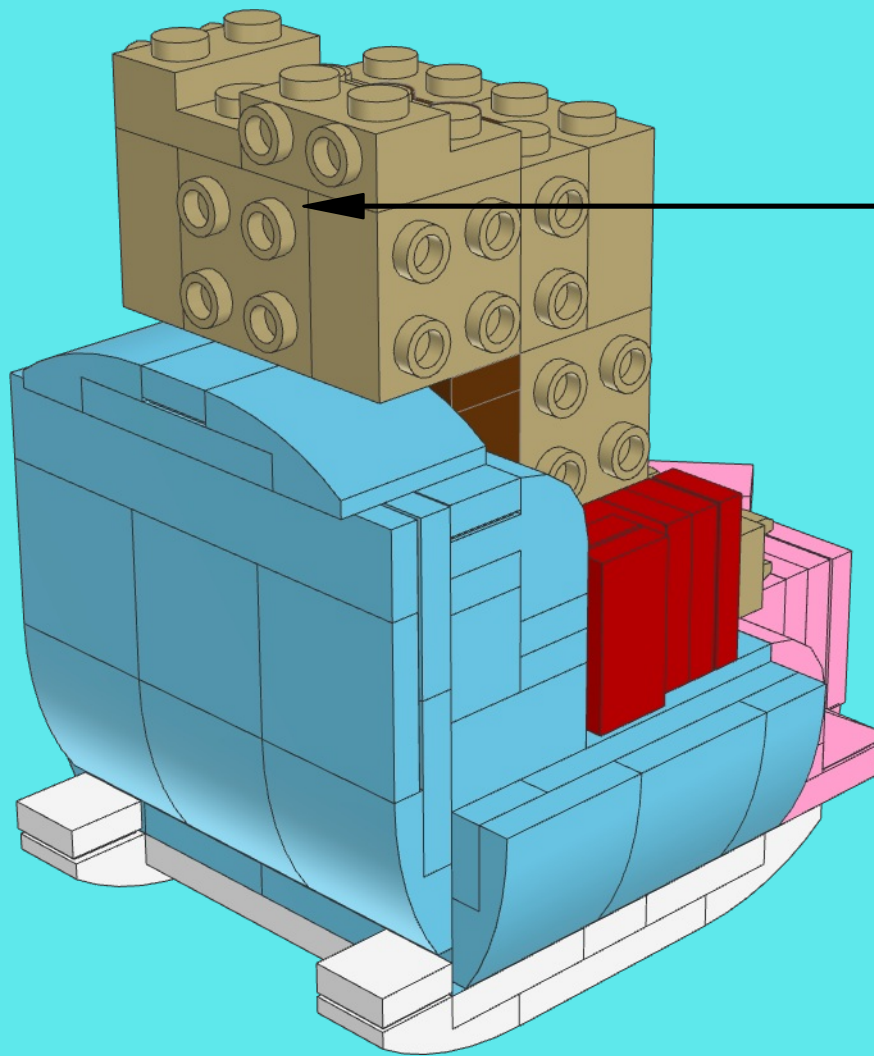

83

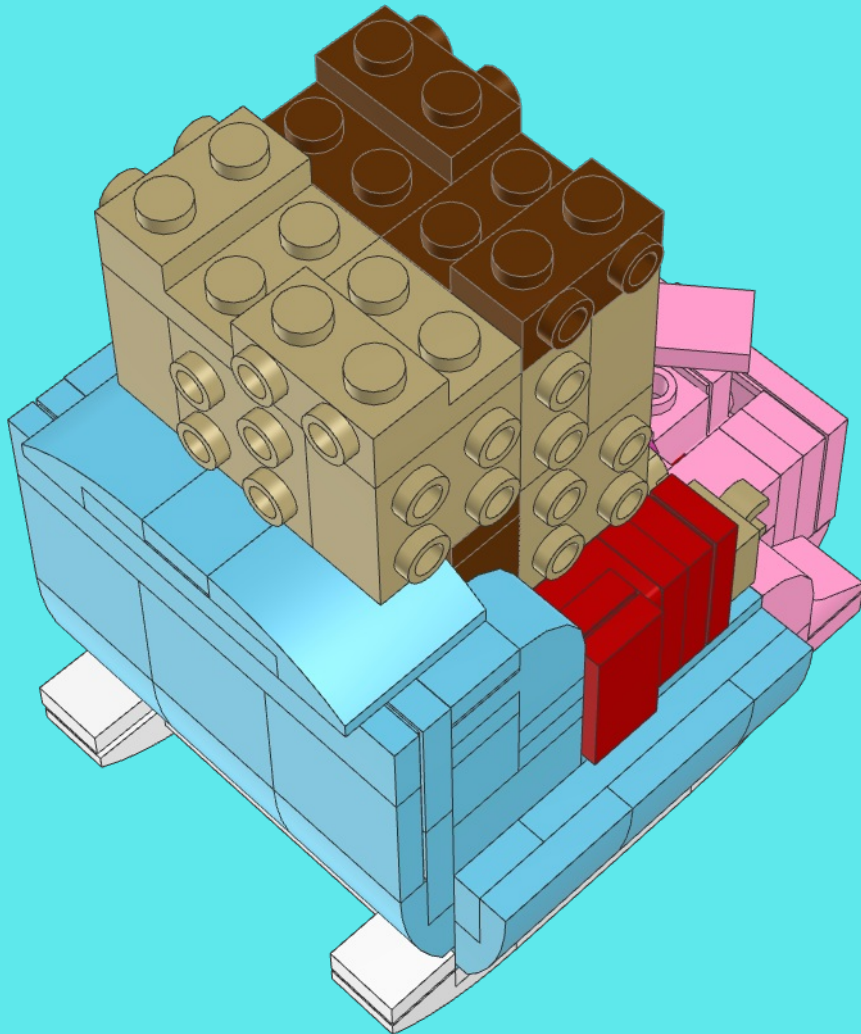
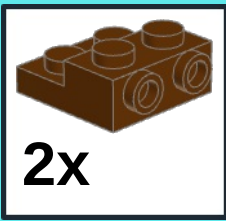

84

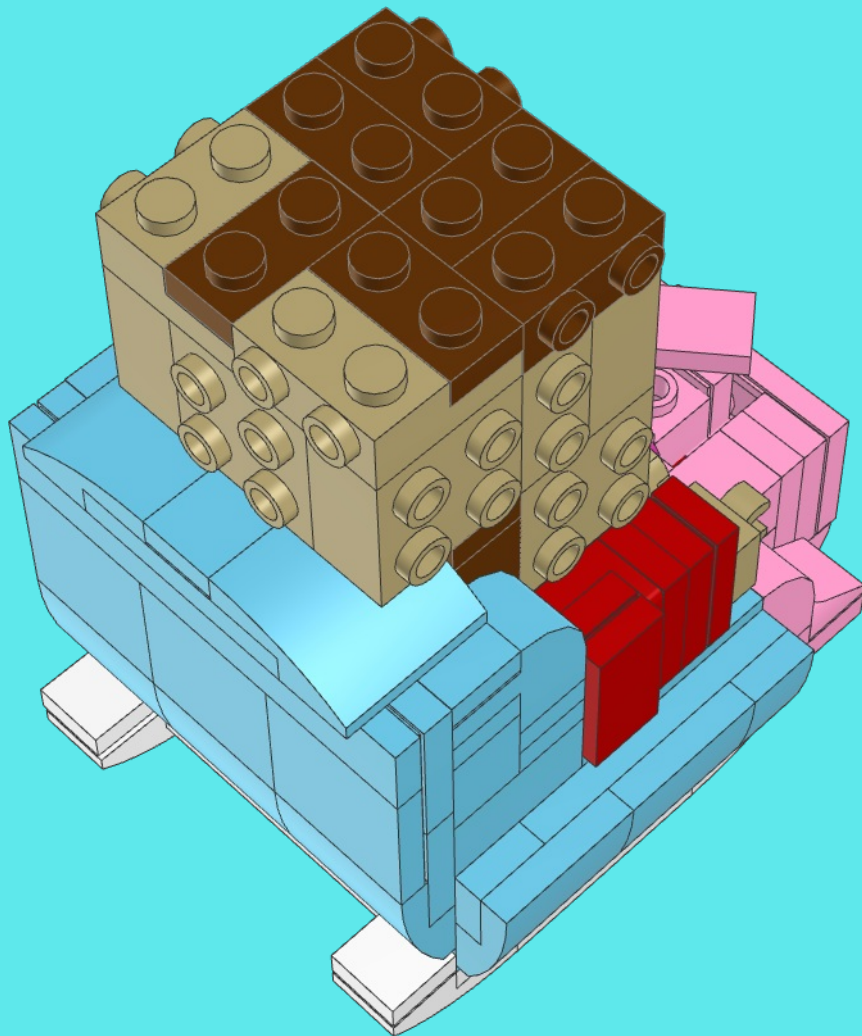

85

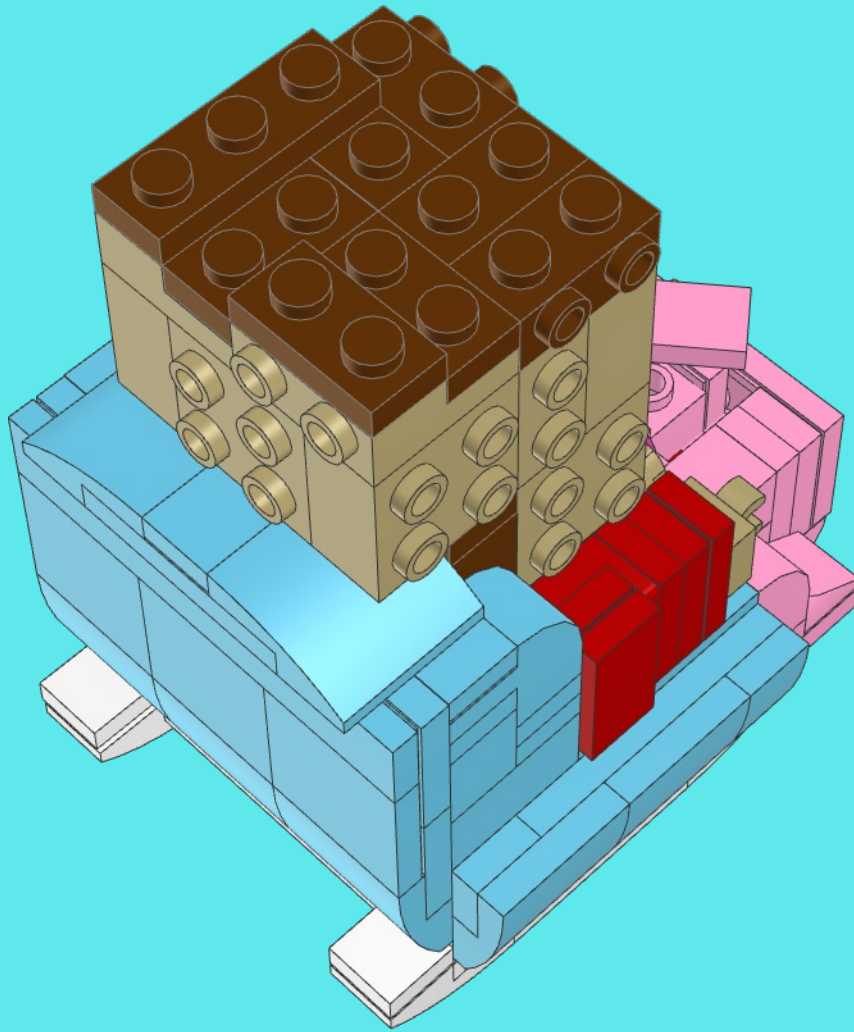
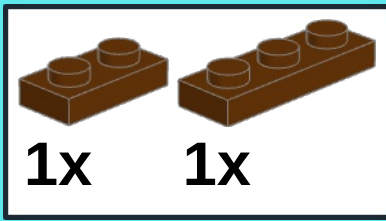

86  6x

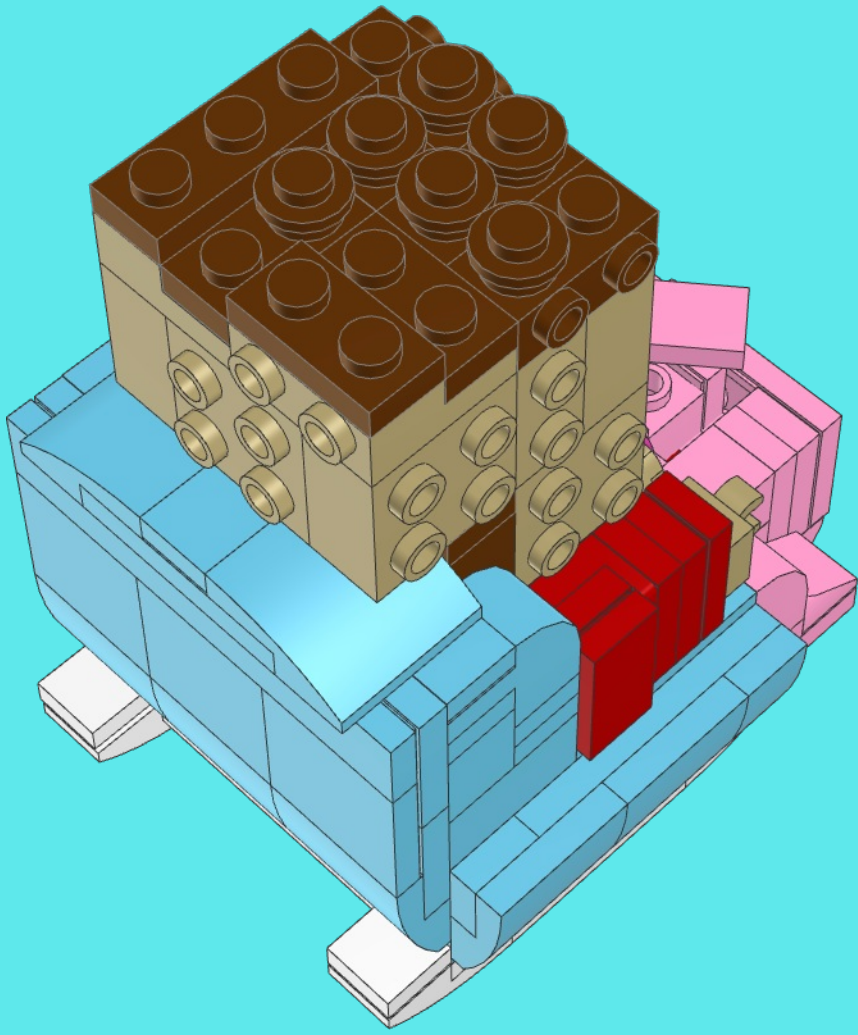

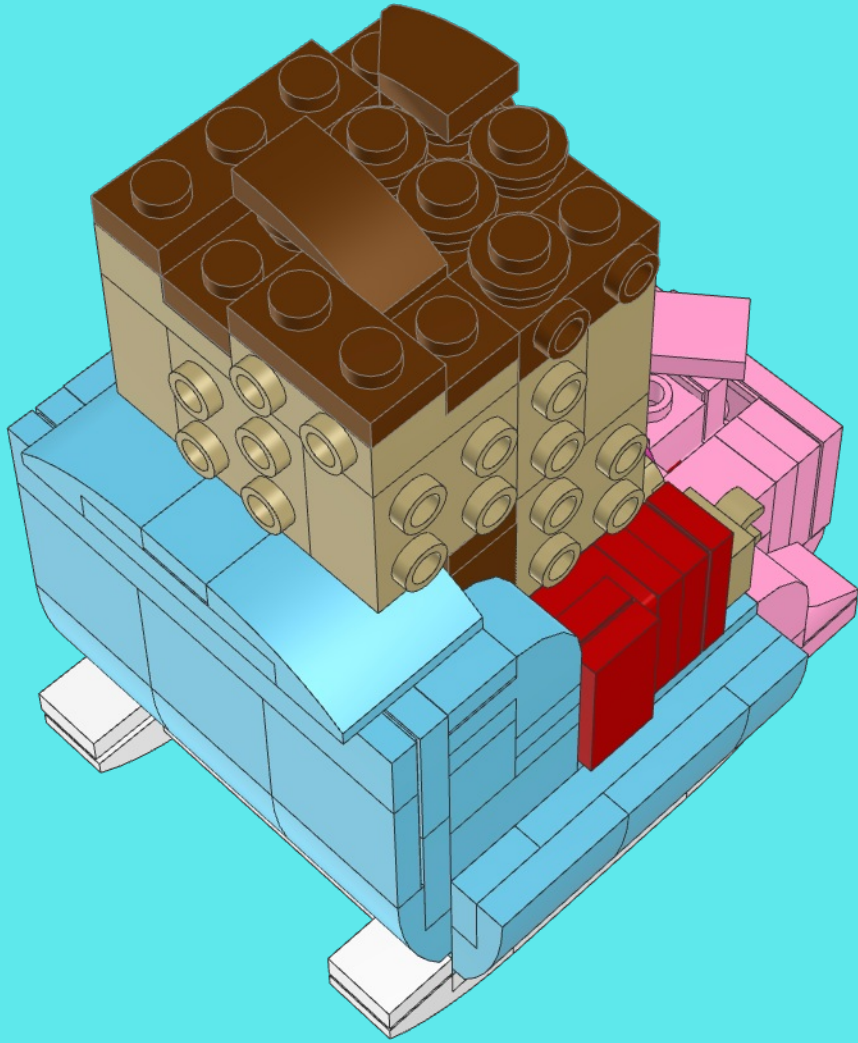
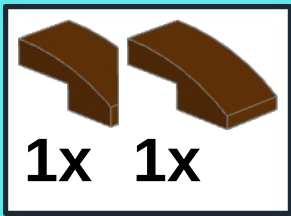

87



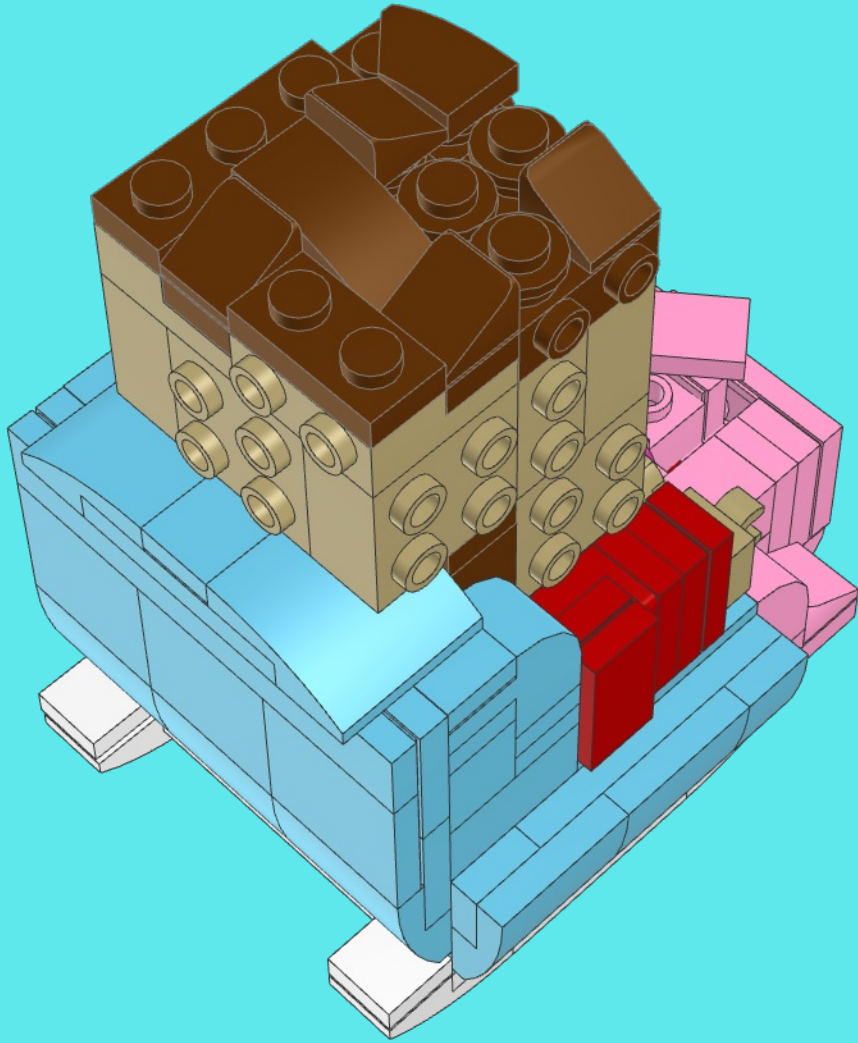

88



89   
4x

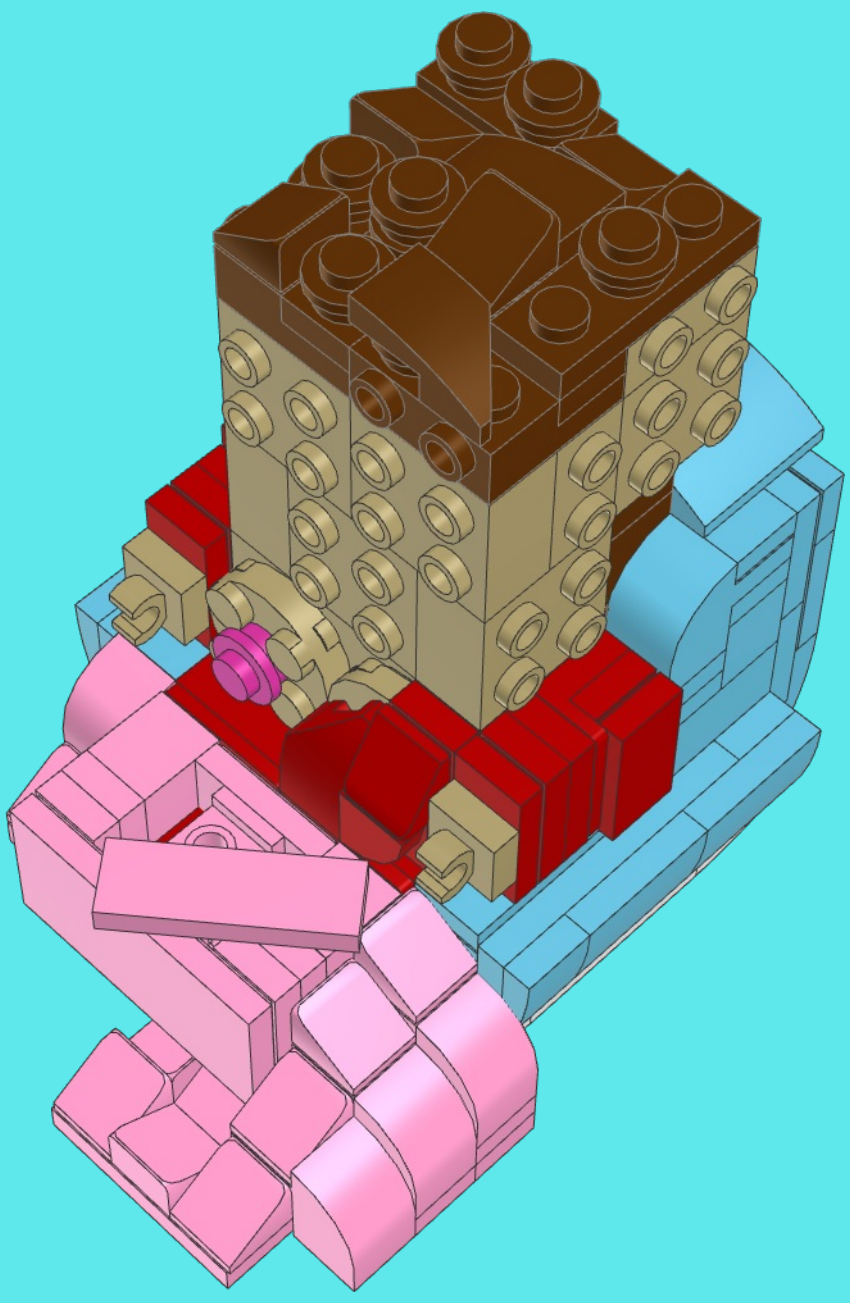

1

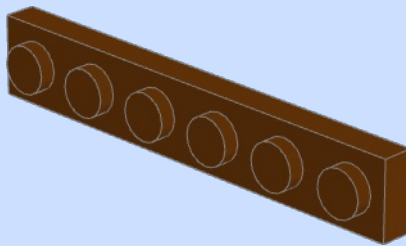
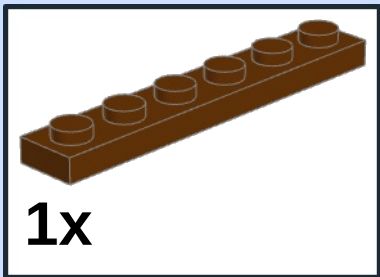

2

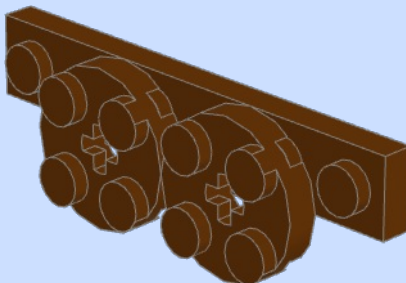
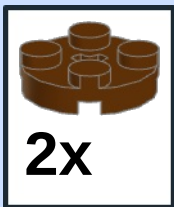

3

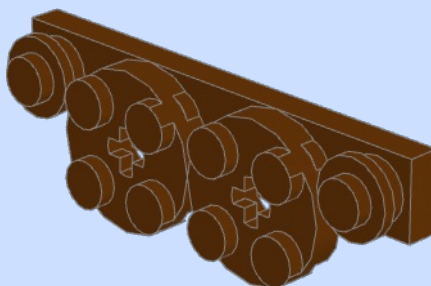
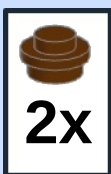

4

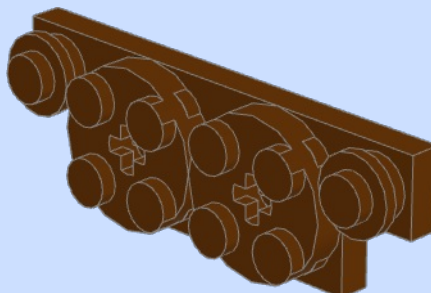
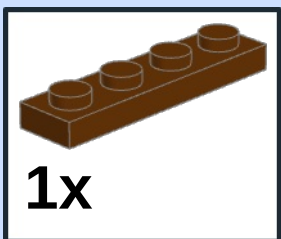

5

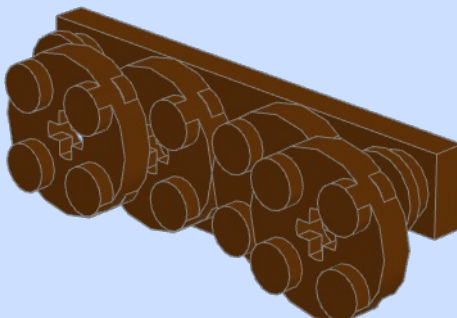
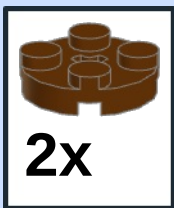

6

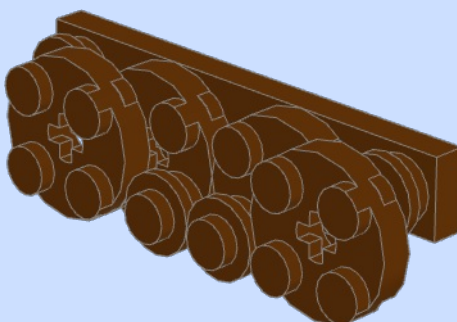

7

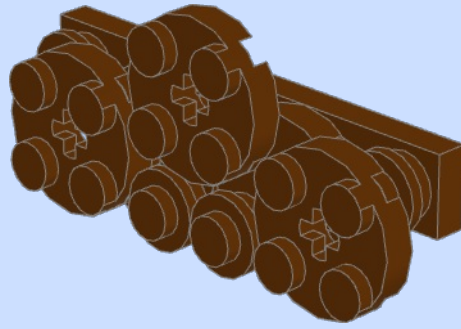
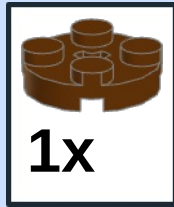

8

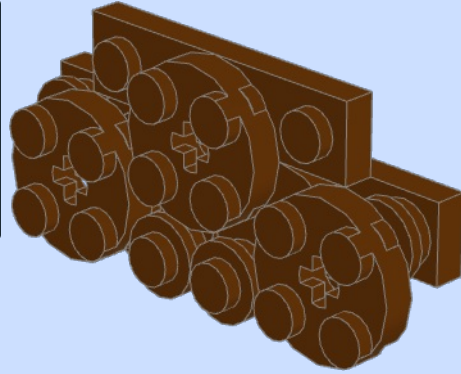
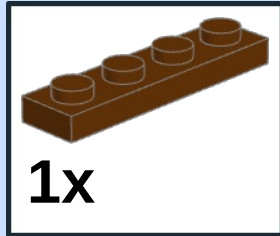

9

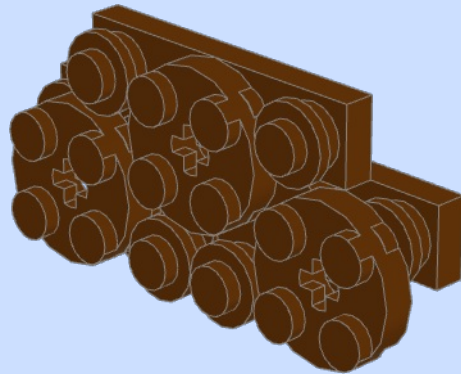

10

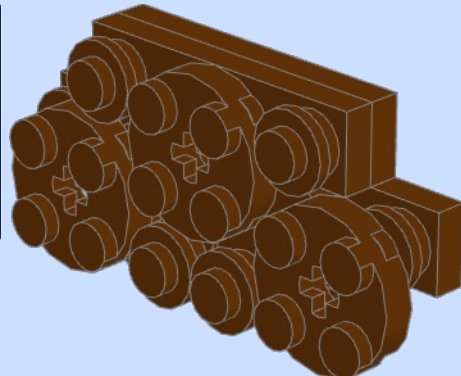
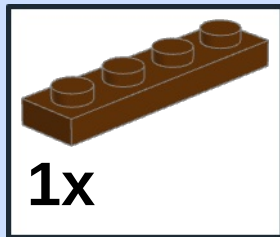

11

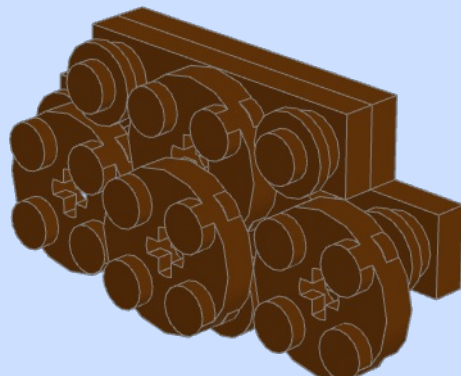
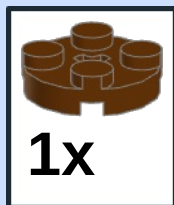

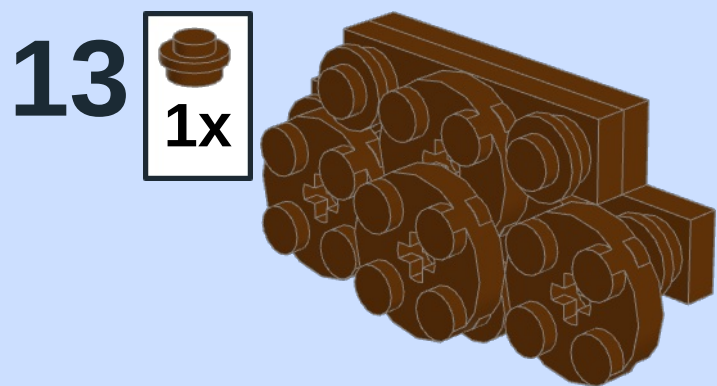
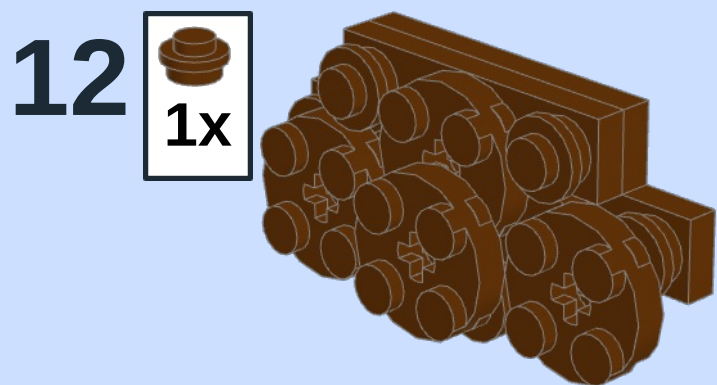

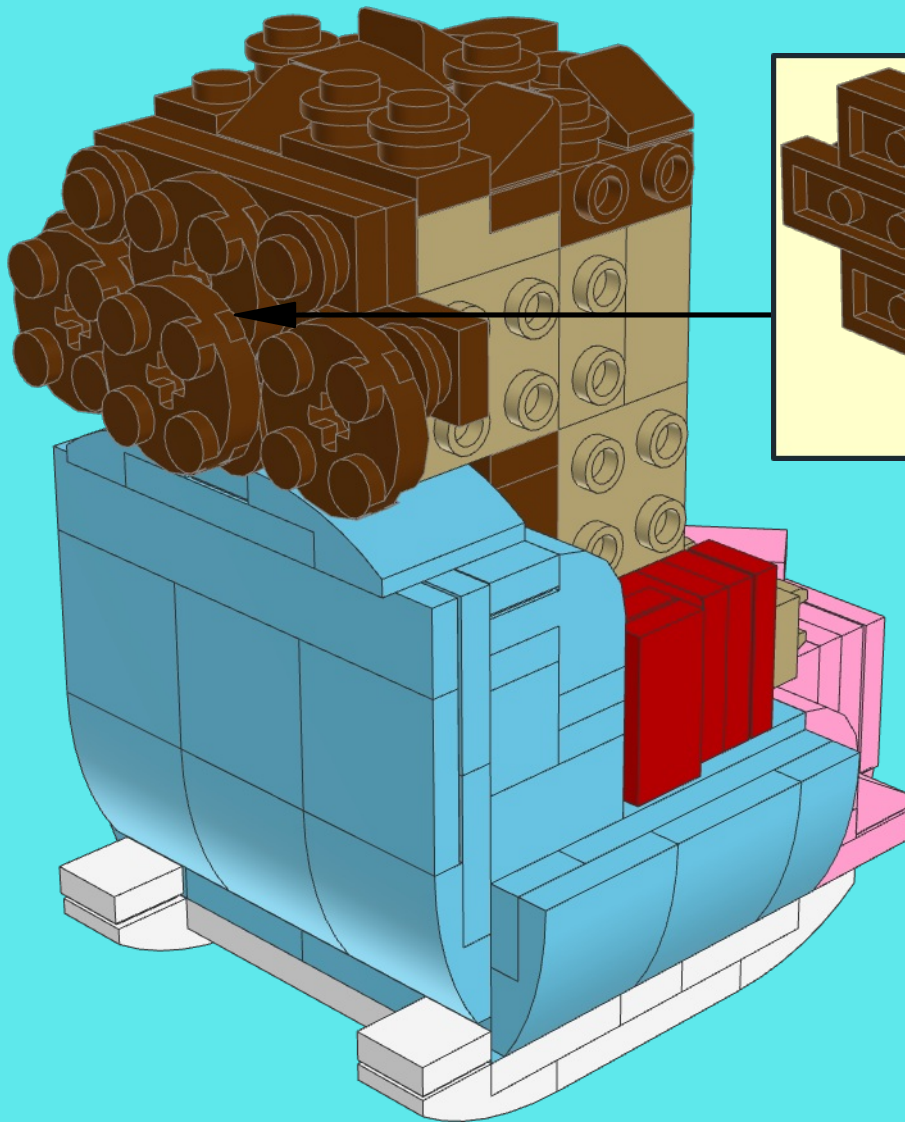

1

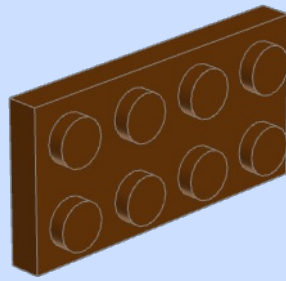
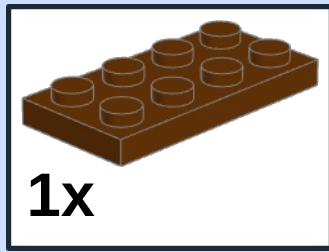

2

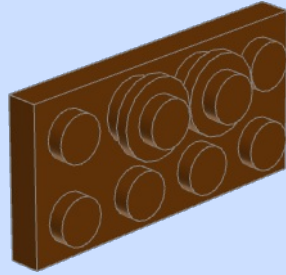

3

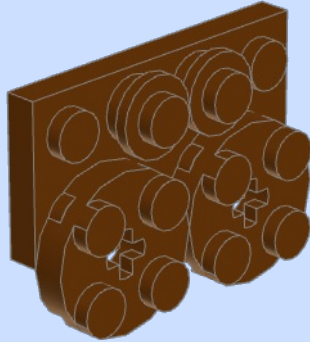
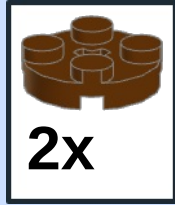

4

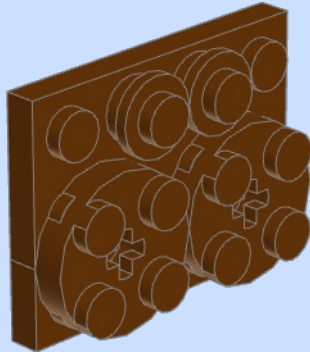
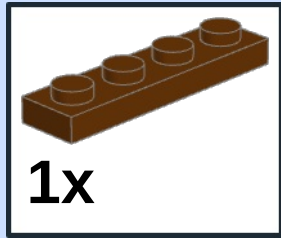

5

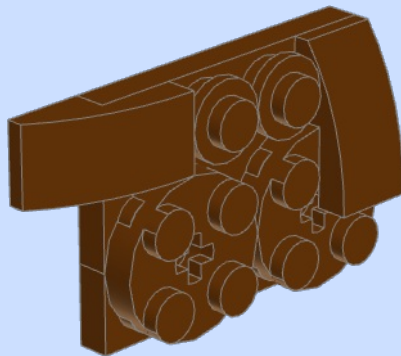

6

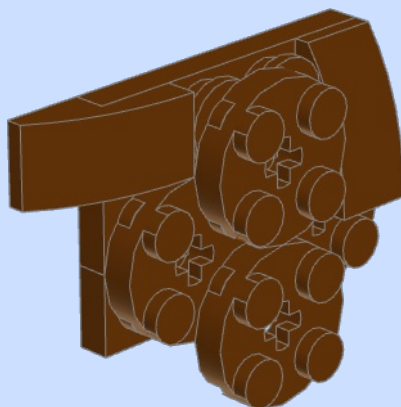

7

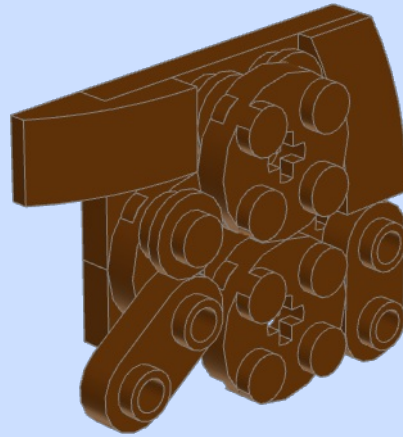

8

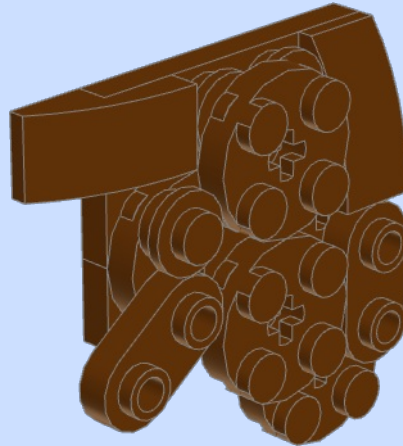
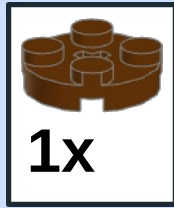

9

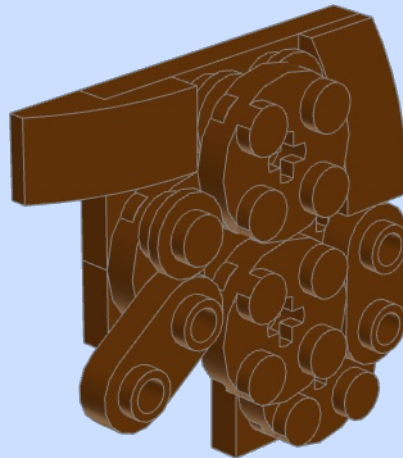
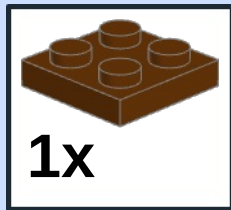

10

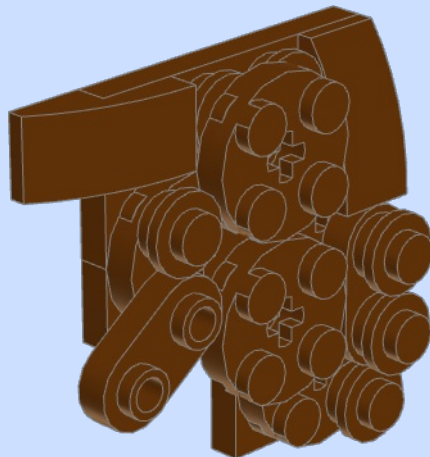



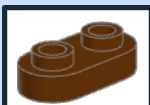

**11**

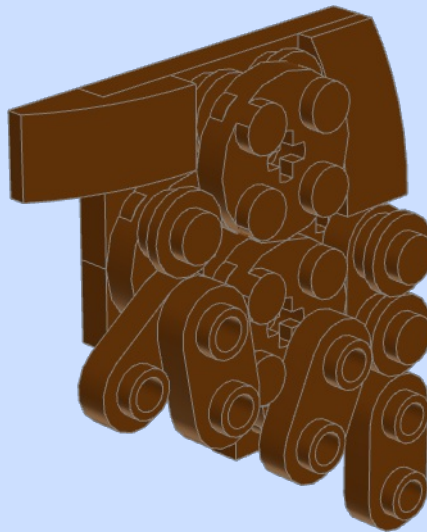

**3x**



**12**



**1x**



**1x**

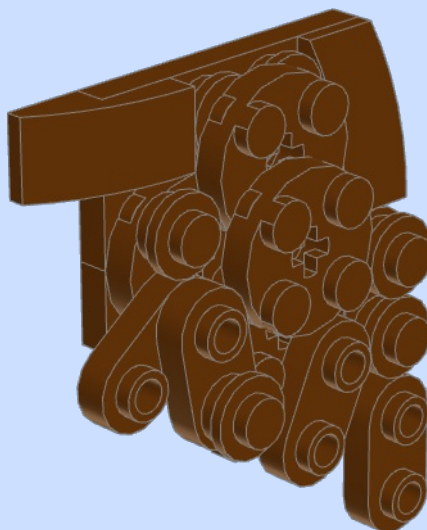

**13**



**1x**

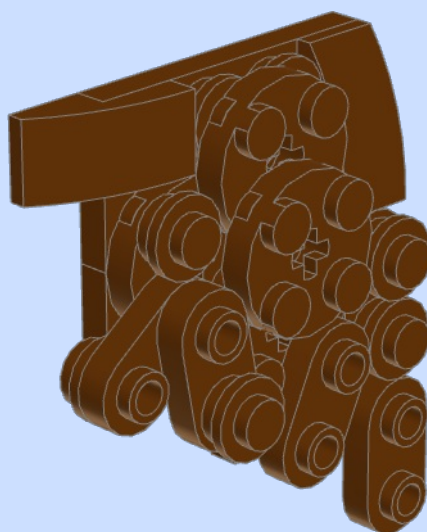

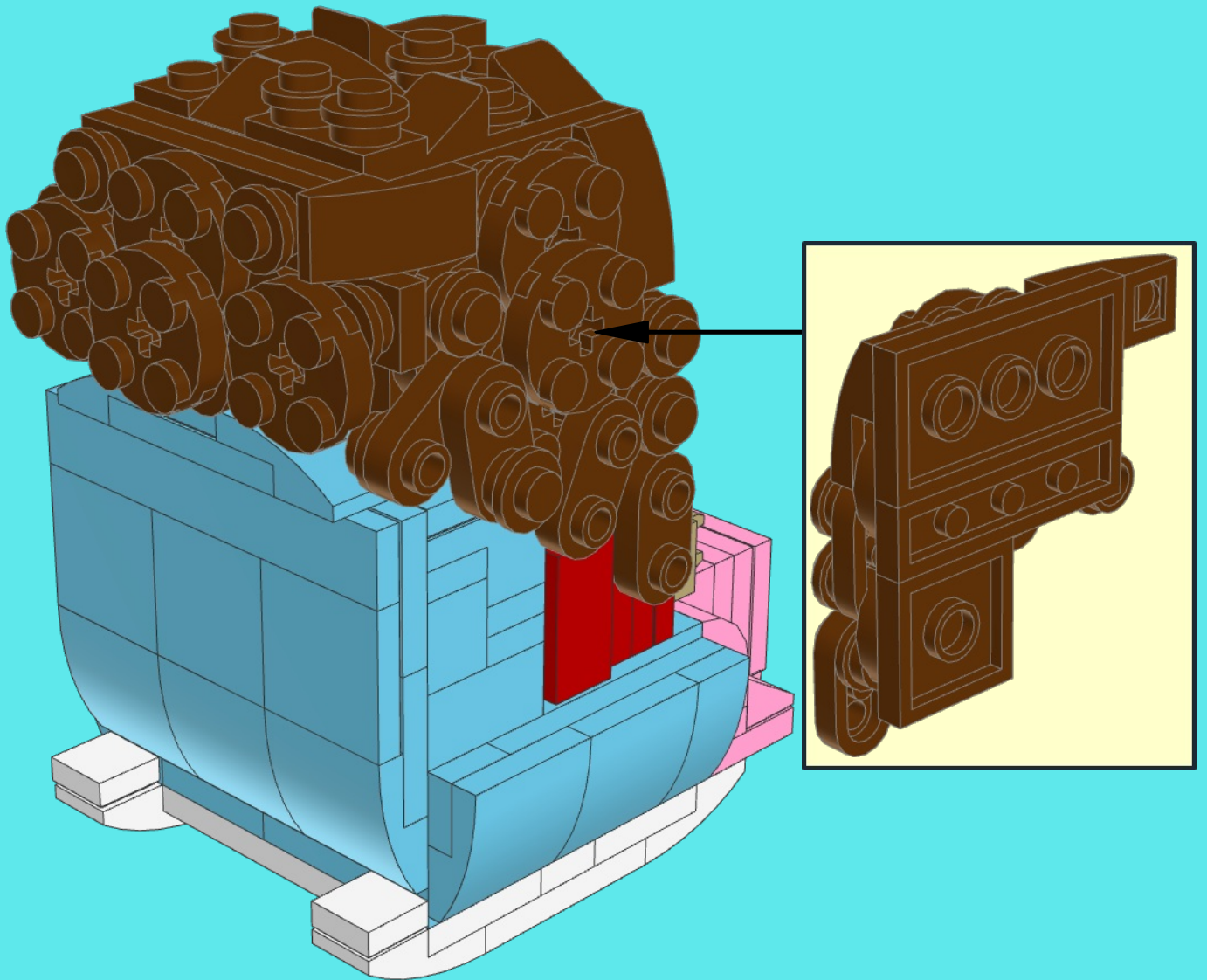

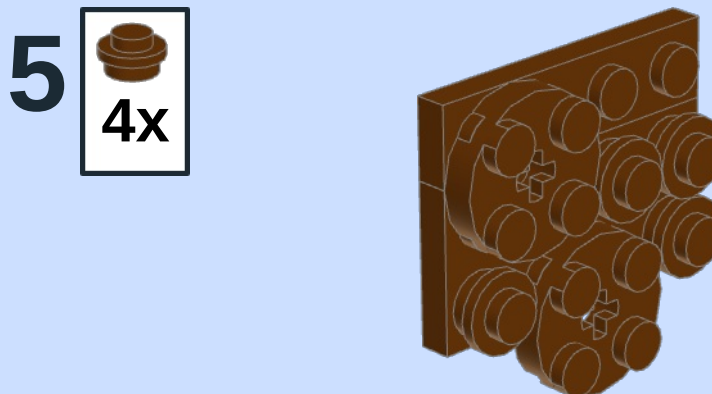
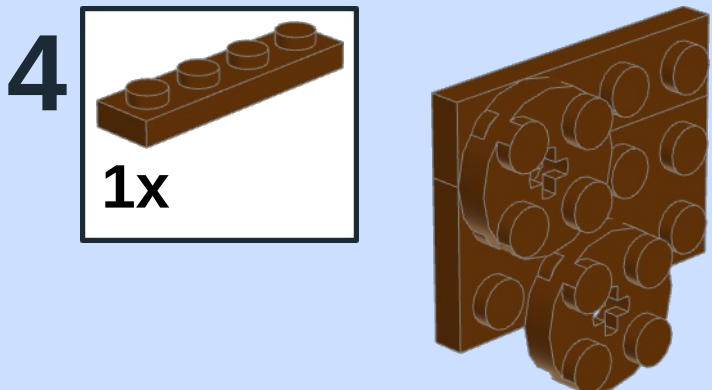
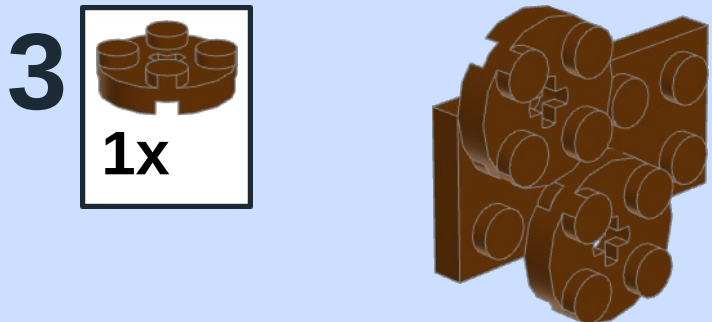
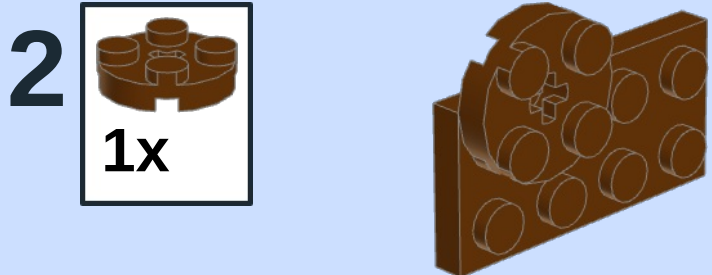
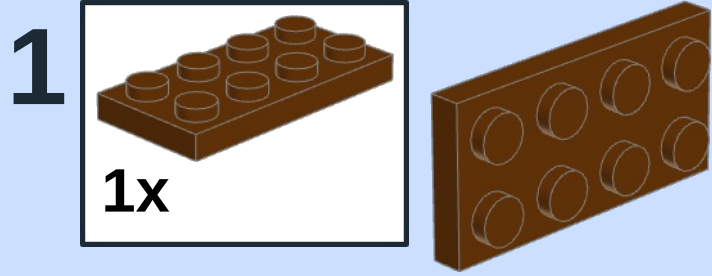

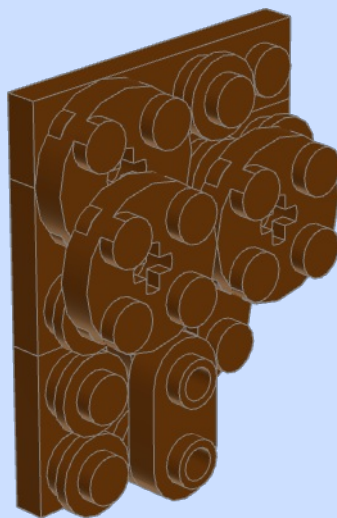
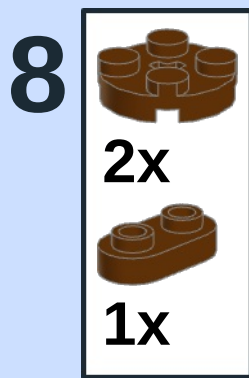
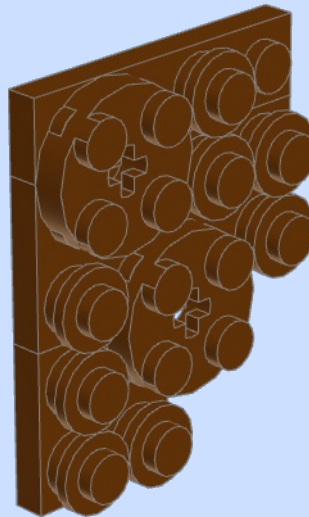
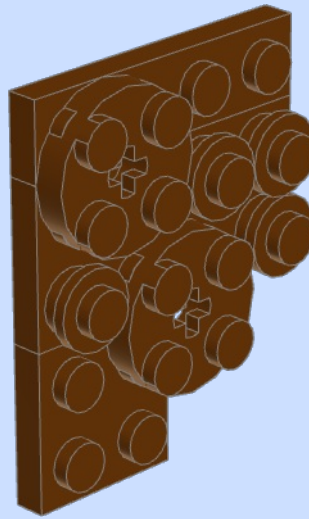
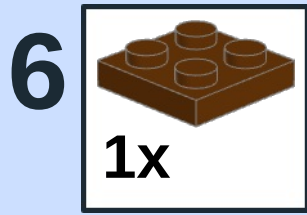

9

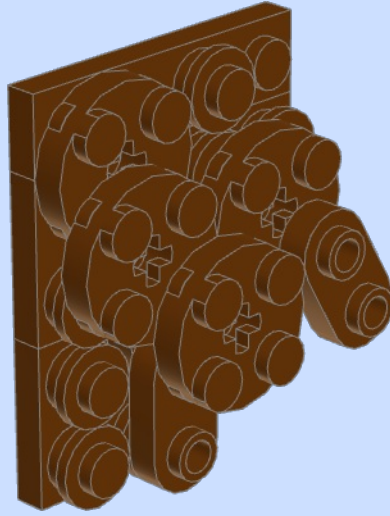
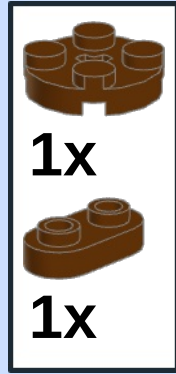

10

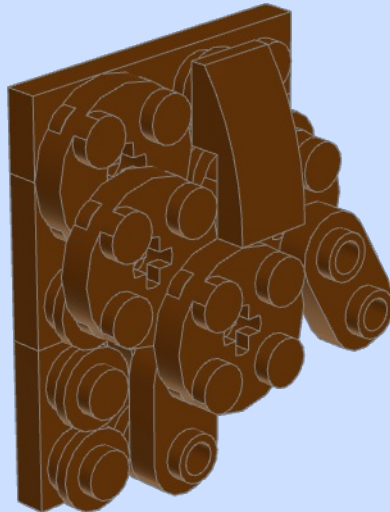
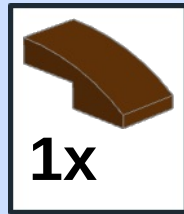

11

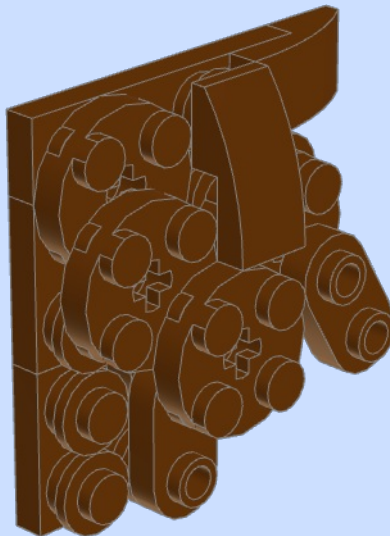
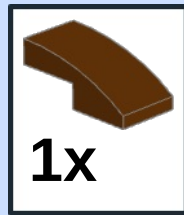

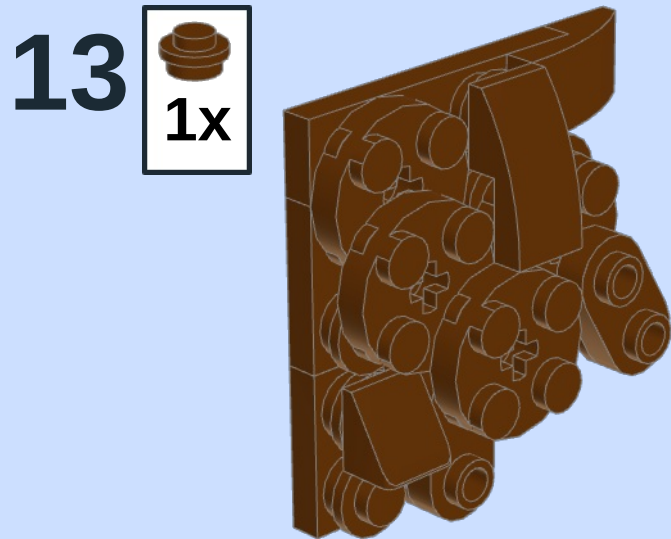
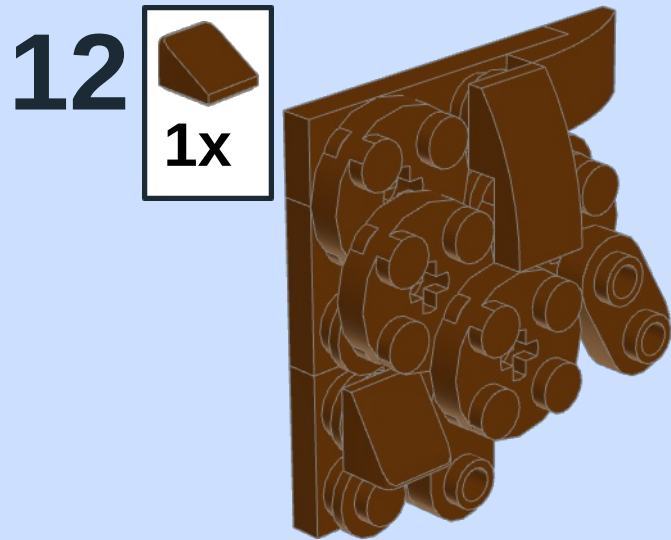

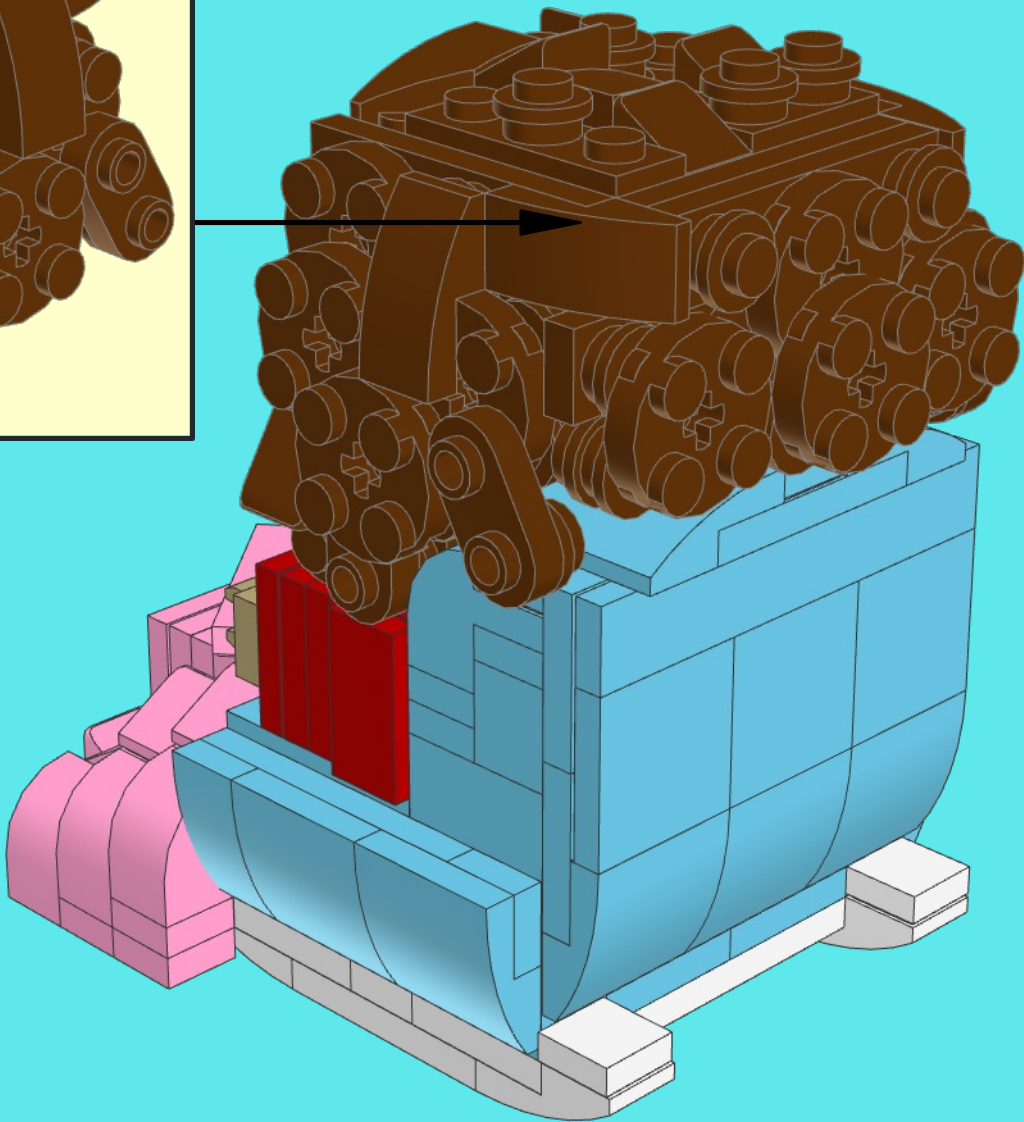
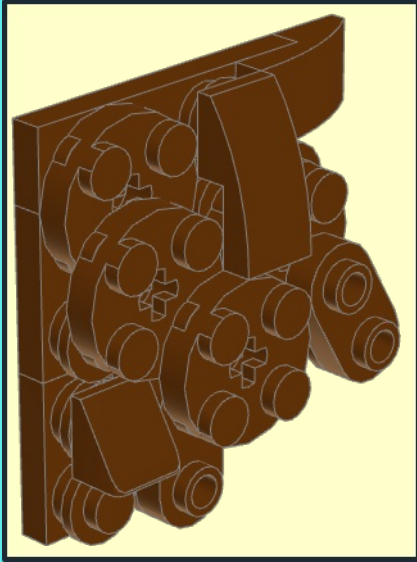

1

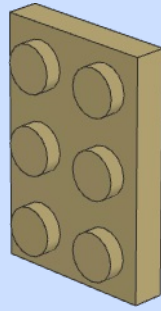
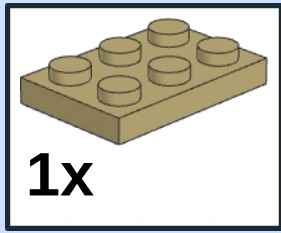

2

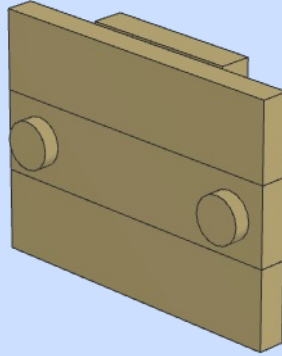
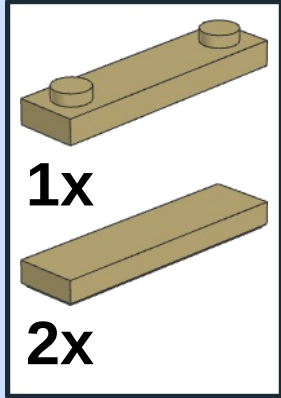

3

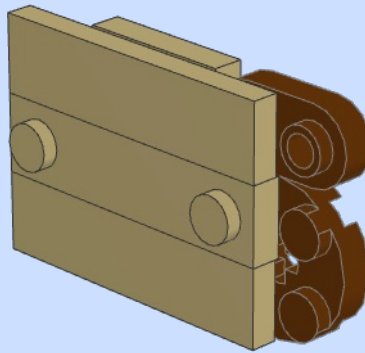
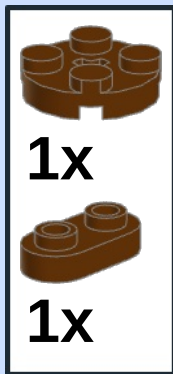

4

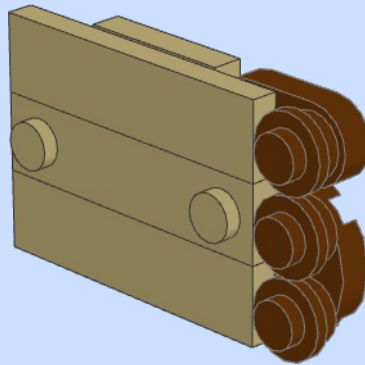

5

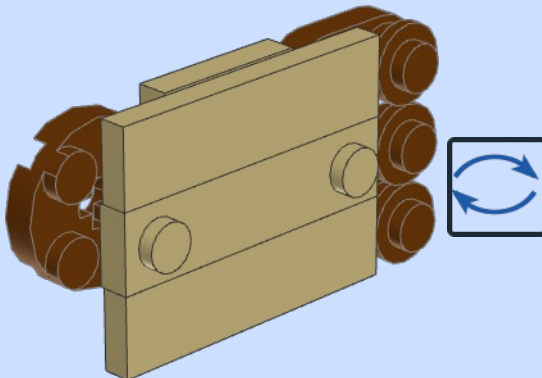
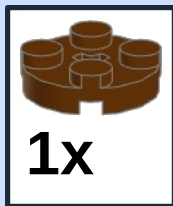



6

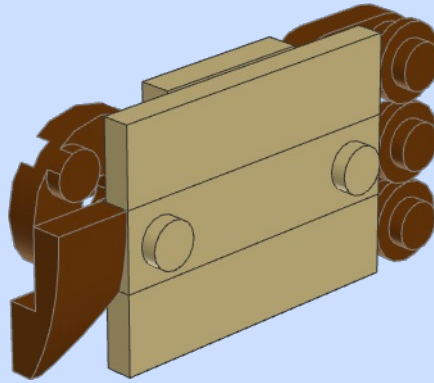

7

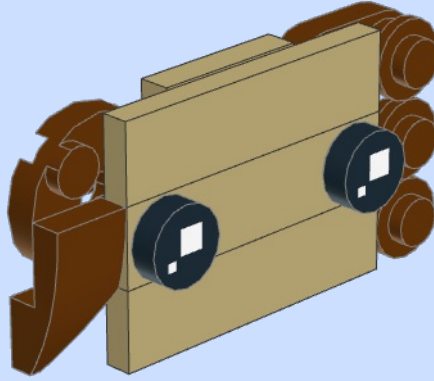

8

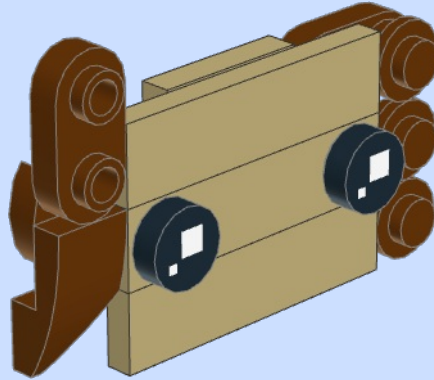
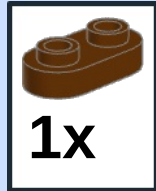

9

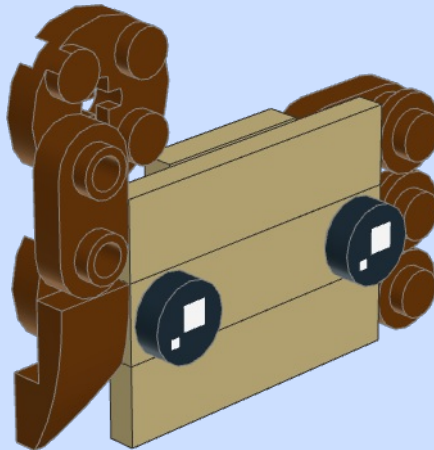
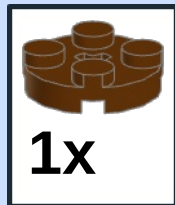

10

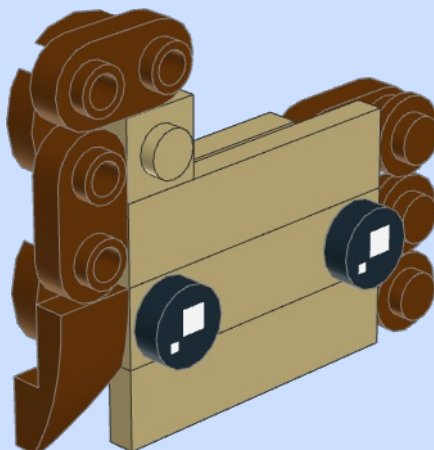

11  3x

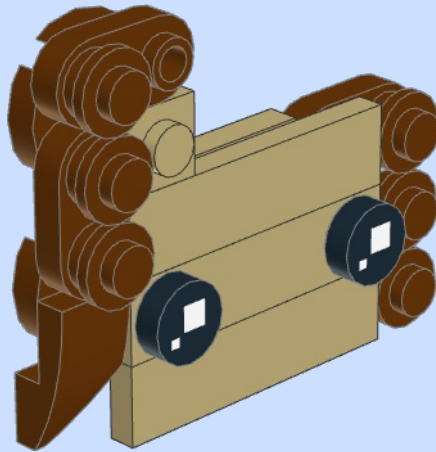

12  1x

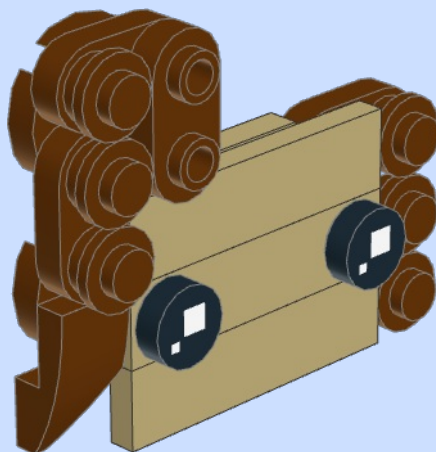

13  1x

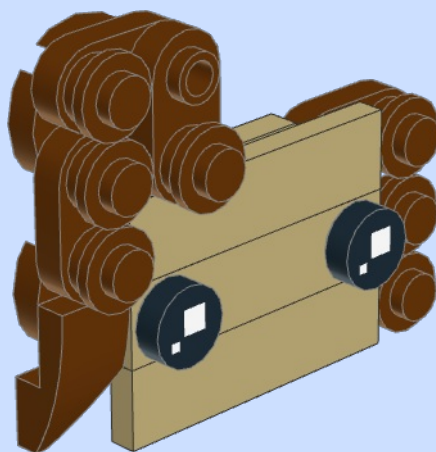

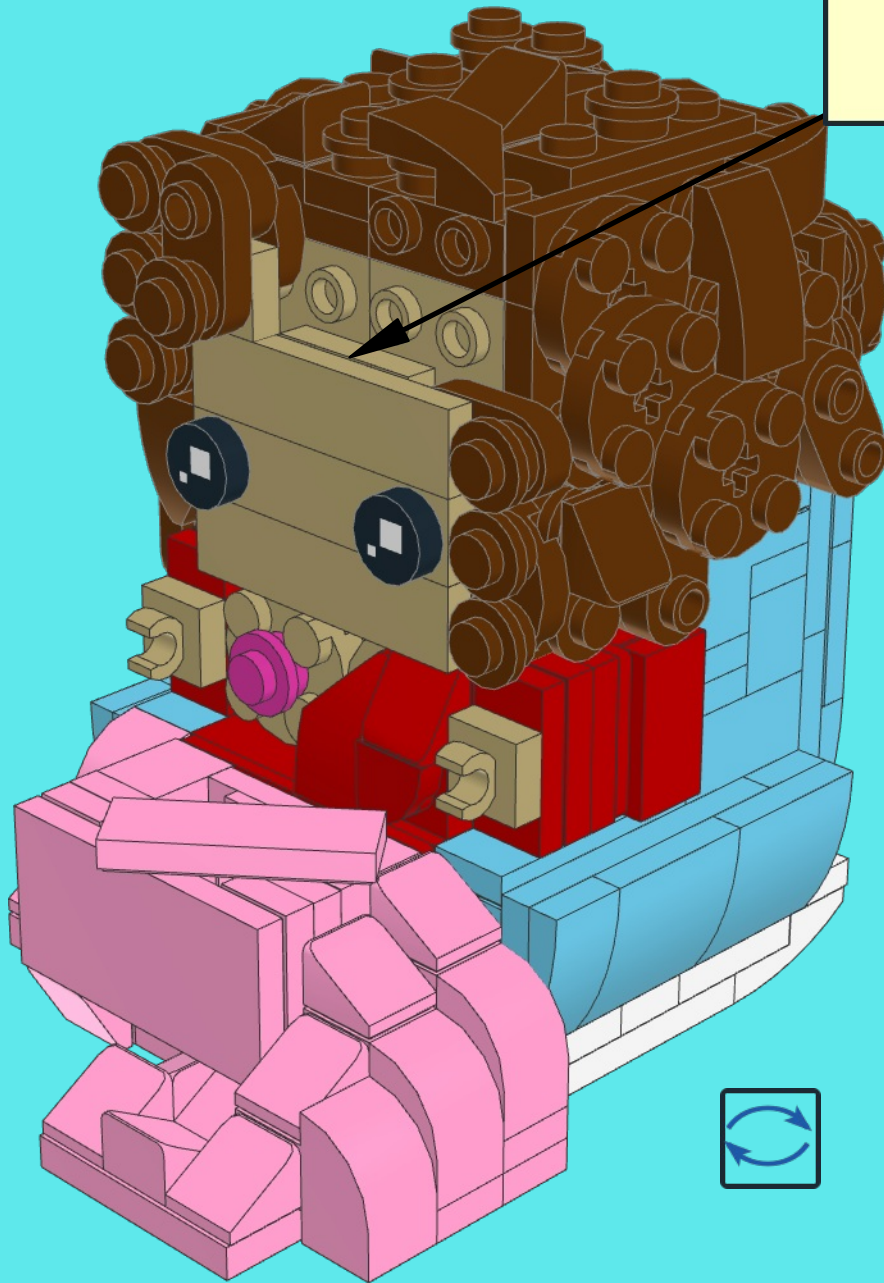
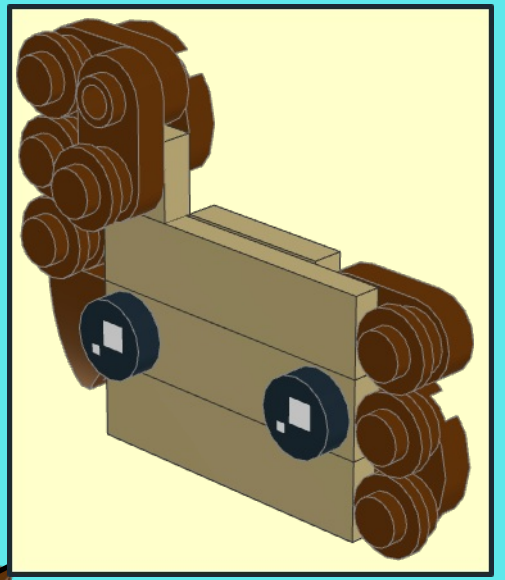

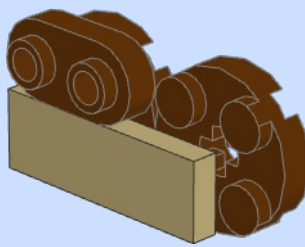
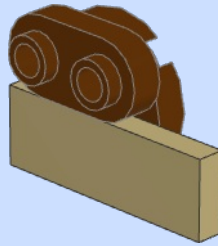
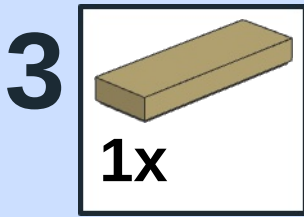
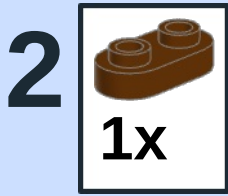
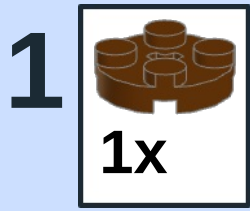

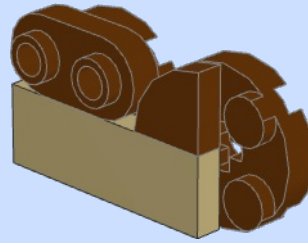

5  1x

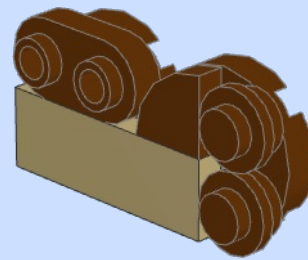

6  2x



7  1x

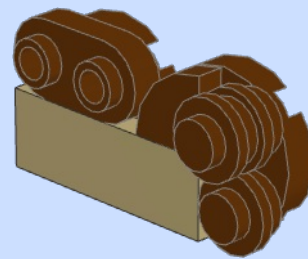

8  1x 1x

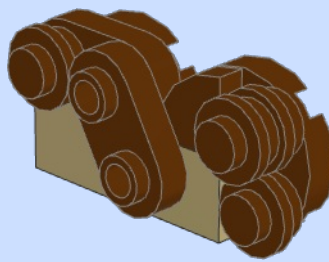

9  1x

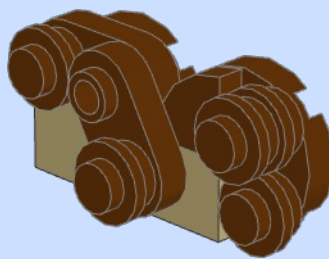



1

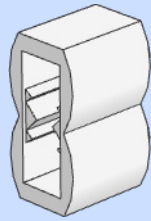
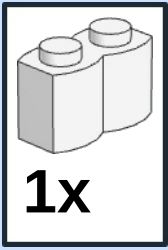

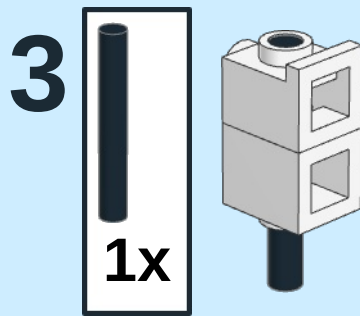
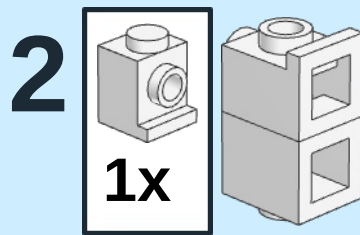
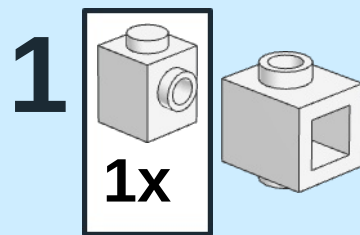



2

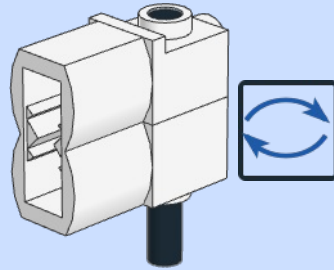

3

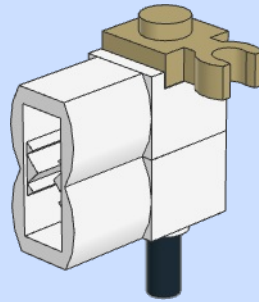
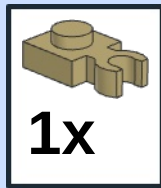

4

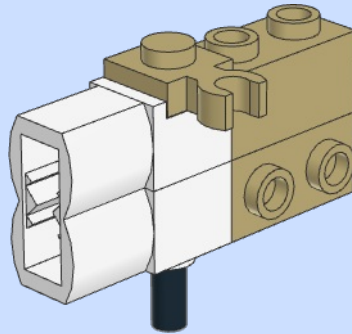
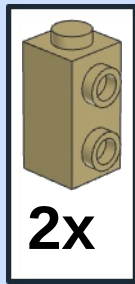

5

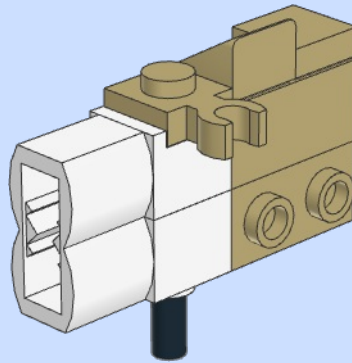

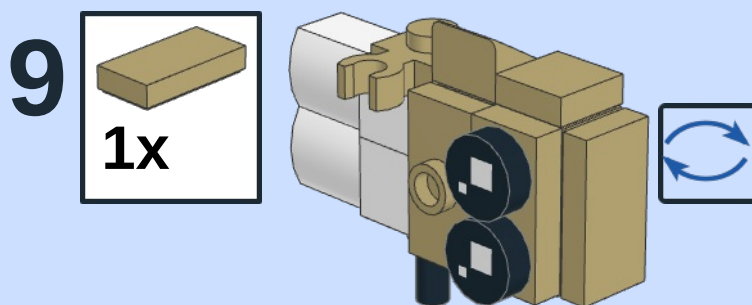
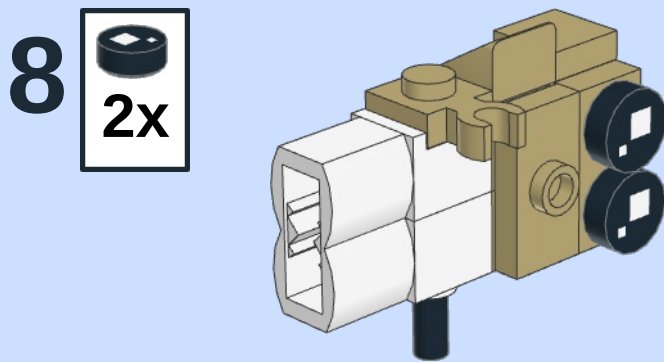
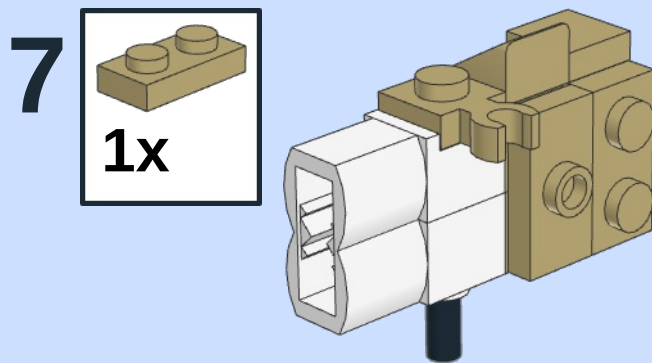
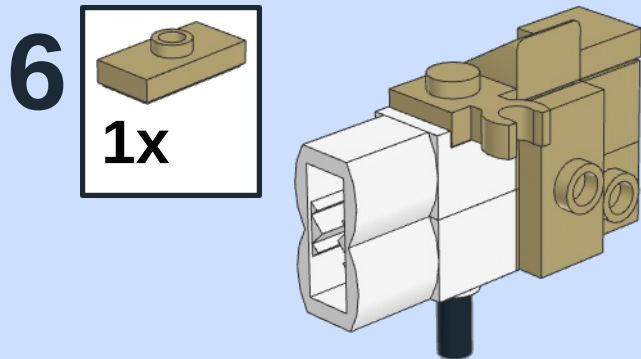

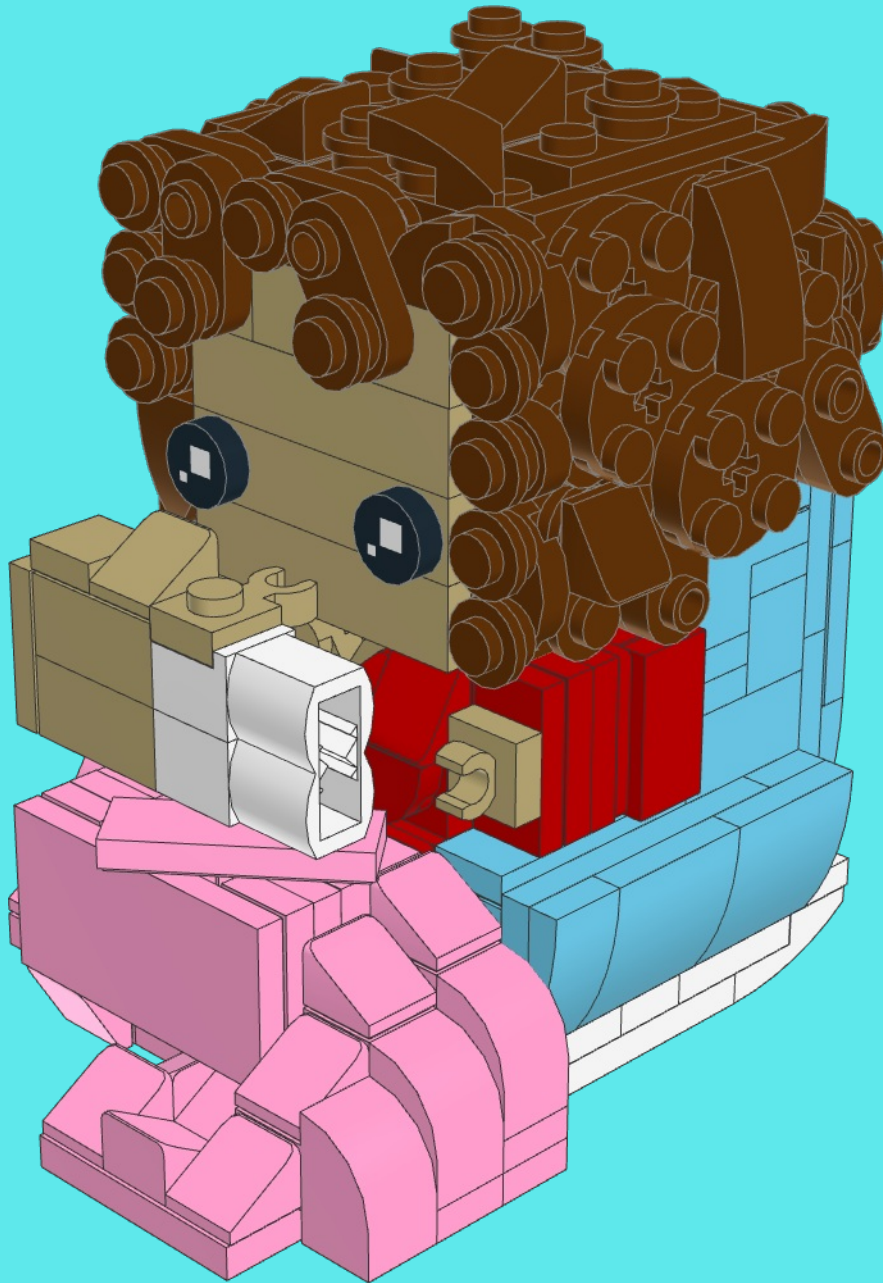

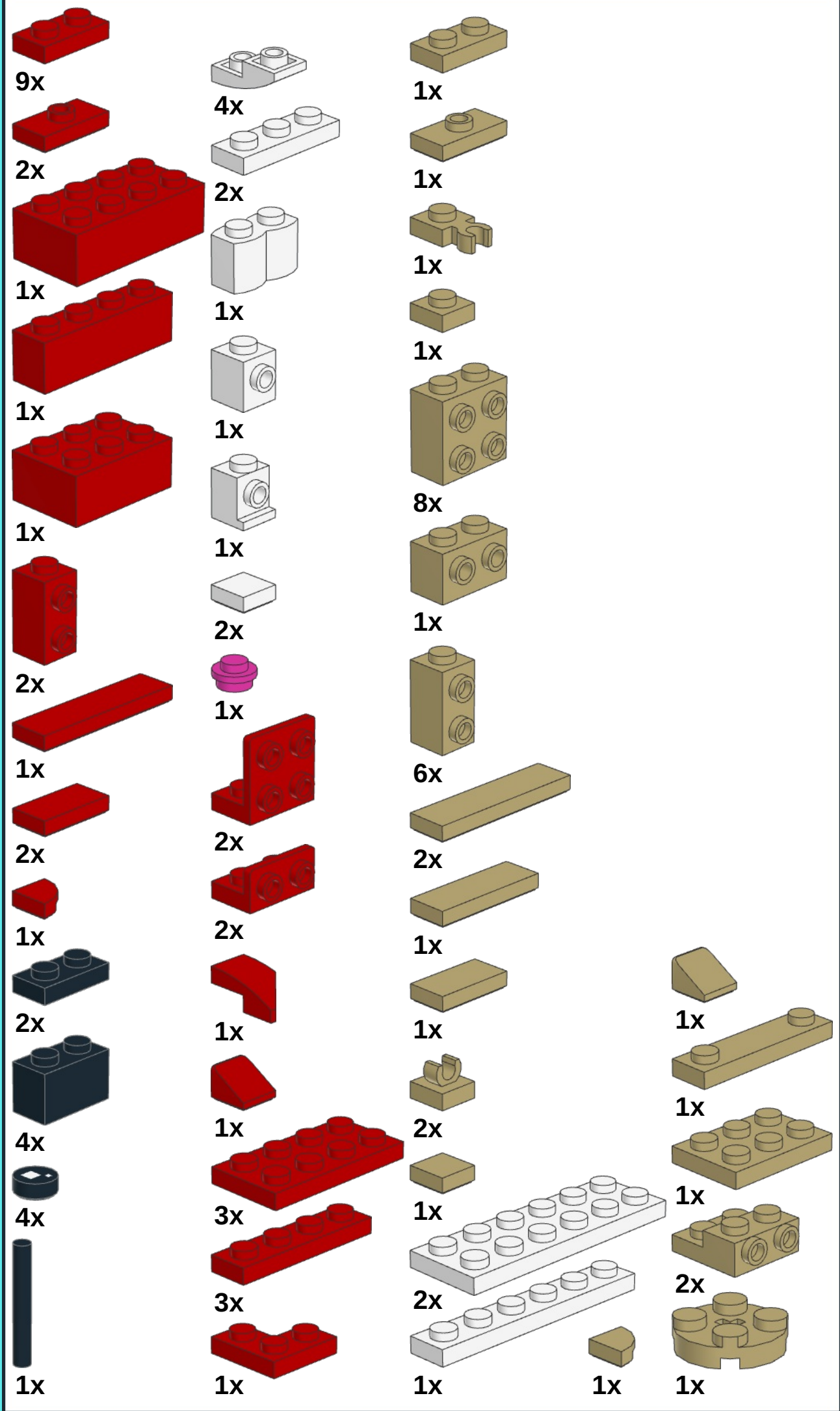

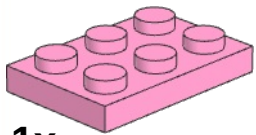

1x

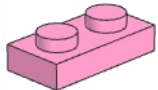

10x

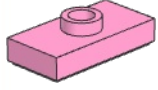

1x

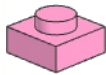

7x

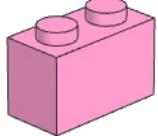

1x

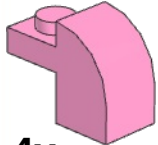

4x



1x



1x

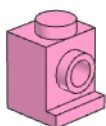

1x

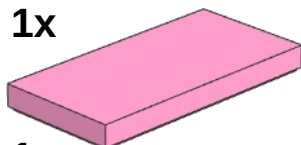

1x

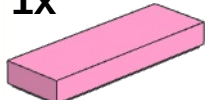

2x



1x

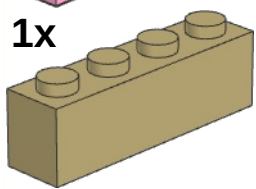

1x

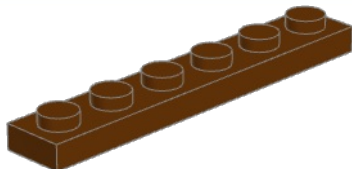

1x

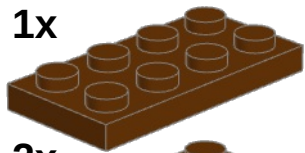

2x

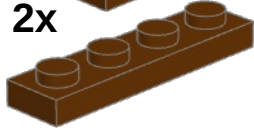

6x

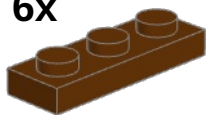

1x

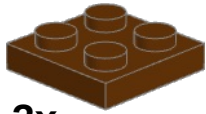

3x

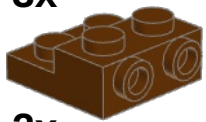

2x

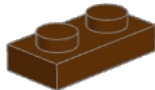

6x



22x



13x



47x

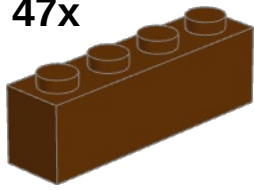

2x

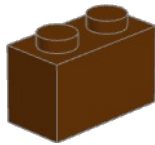

1x



1x



10x

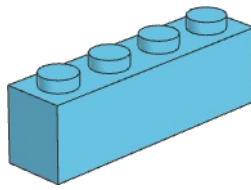

3x

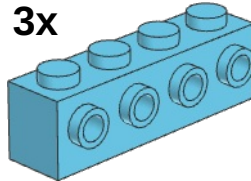

3x

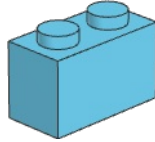

2x

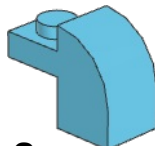

2x



4x

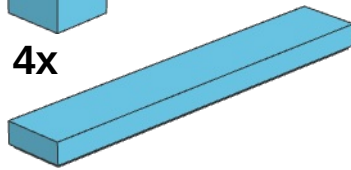

1x

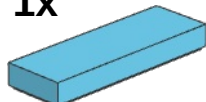

2x

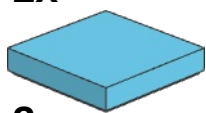

3x

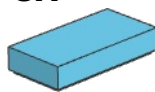

1x

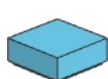

2x



5x



2x



5x

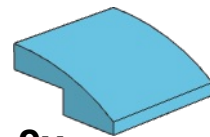

9x

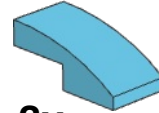

2x

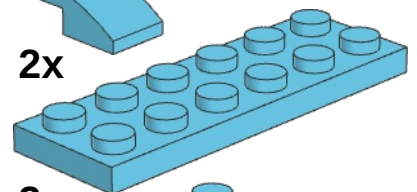

2x

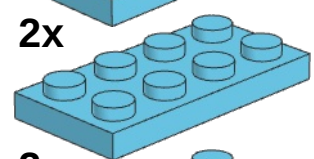

2x

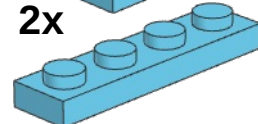

7x

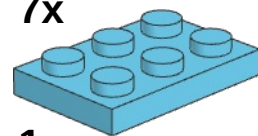

1x

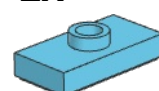

2x

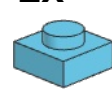

11x

# *Honorable mentions of supporters:*

Teg12345

dalesr

csscg



Hope you had fun with this model and instructions.

As always you can reach out to me via email:

[birdbrickbuilds@gmail.com](mailto:birdbrickbuilds@gmail.com)

You can also check my work on rebrickable and instagram:

<https://rebrickable.com/users/birdbrickbuilds/>

<https://www.instagram.com/birdbrickbuilds/>

If you wish to help me continue to make this models and instructions you can buy me a coffee to help me stay up late:

<https://www.buymeacoffee.com/birdbrickbl>

Or you can buy my Coffee Espresso MOC:

<https://reb.li/m/118798>

Or even you can buy my Beer Mug MOC:

<https://reb.li/m/137364>



This work is licensed under a [Creative Commons Attribution-NonCommercial-ShareAlike 4.0 International License](https://creativecommons.org/licenses/by-nc-sa/4.0/).